

Tělesa

Pavel Štarha

Vysoké učení technické v Brně
Fakulta strojního inženýrství
Technická 2, 616 69 Brno

starha@fme.vutbr.cz

Mongeovo promítání - jehlan

$\alpha(-70,40,50)$
A[20,10,?]
B[-20,20,?]
 $v=50$

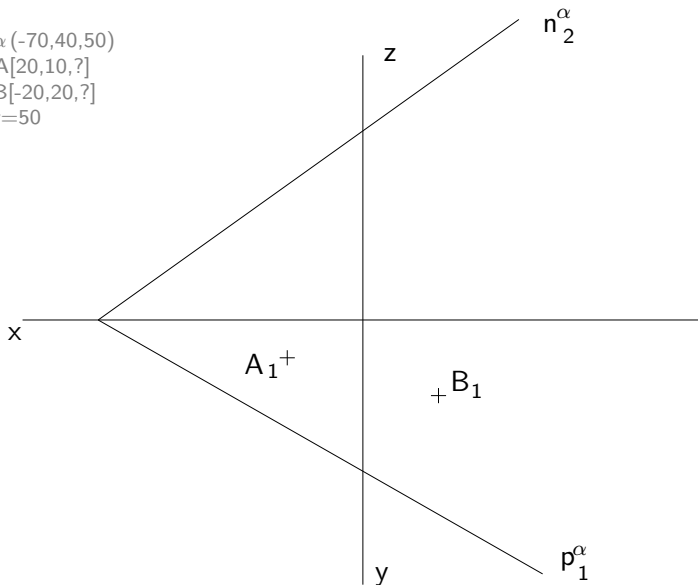

Mongeovo promítání - jehlan

$\alpha(-70,40,50)$
A[20,10,?]
B[-20,20,?]
 $v=50$

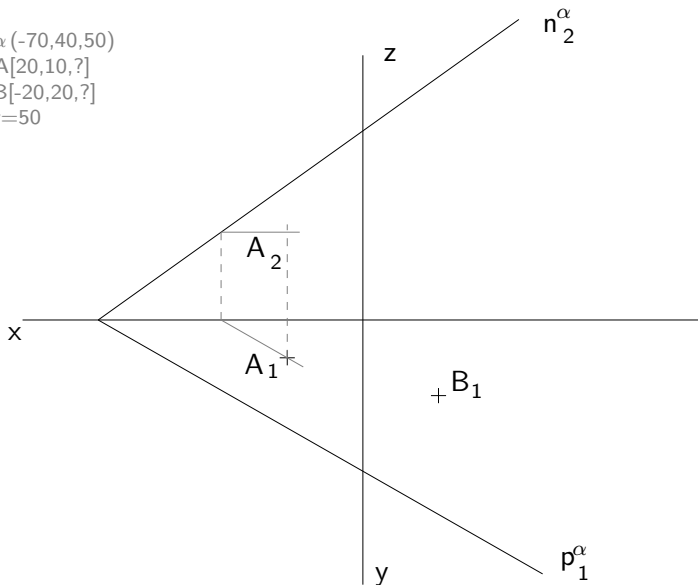

Mongeovo promítání - jehlan

$\alpha(-70,40,50)$
 $A[20,10,?]$
 $B[-20,20,?]$
 $v=50$

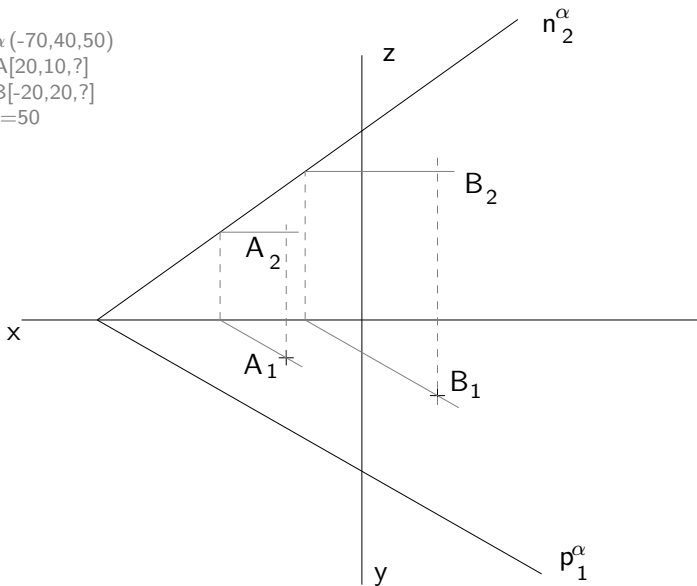

Mongeovo promítání - jehlan

$\alpha(-70,40,50)$
 $A[20,10,?]$
 $B[-20,20,?]$
 $v=50$

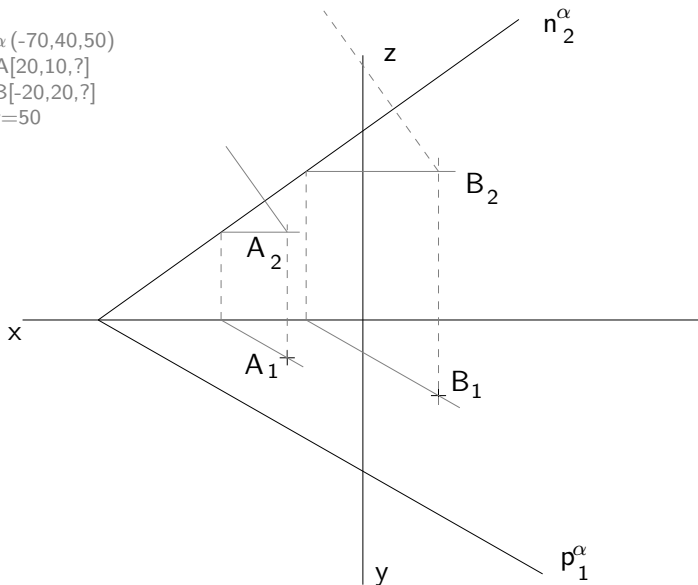

Mongeovo promítání - jehlan

$\alpha(-70,40,50)$
 $A[20,10,?]$
 $B[-20,20,?]$
 $v=50$

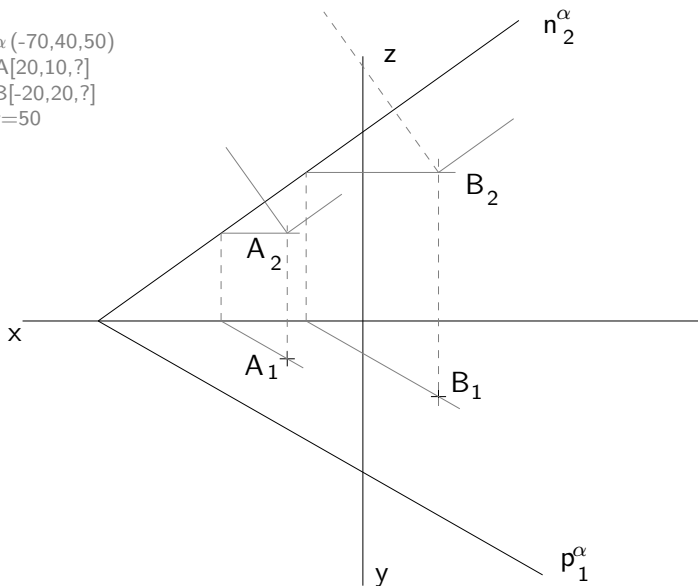

Mongeovo promítání - jehlan

$\alpha(-70,40,50)$
 $A[20,10,?]$
 $B[-20,20,?]$
 $v=50$

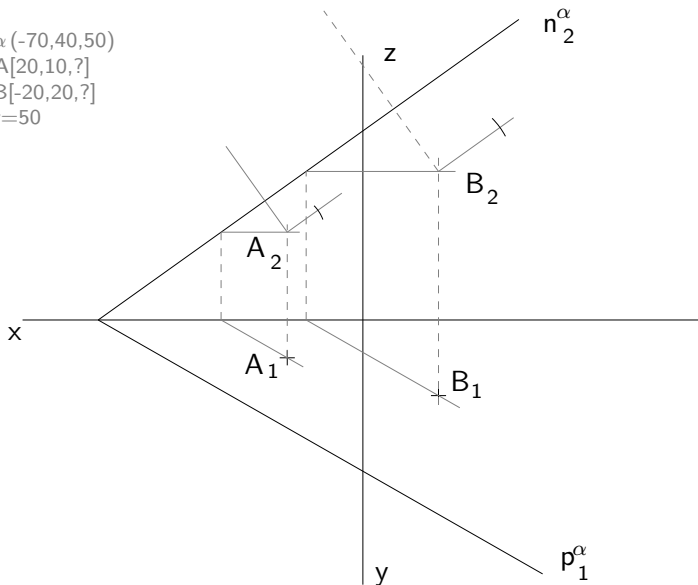

Mongeovo promítání - jehlan

$\alpha(-70,40,50)$
 $A[20,10,?]$
 $B[-20,20,?]$
 $v=50$

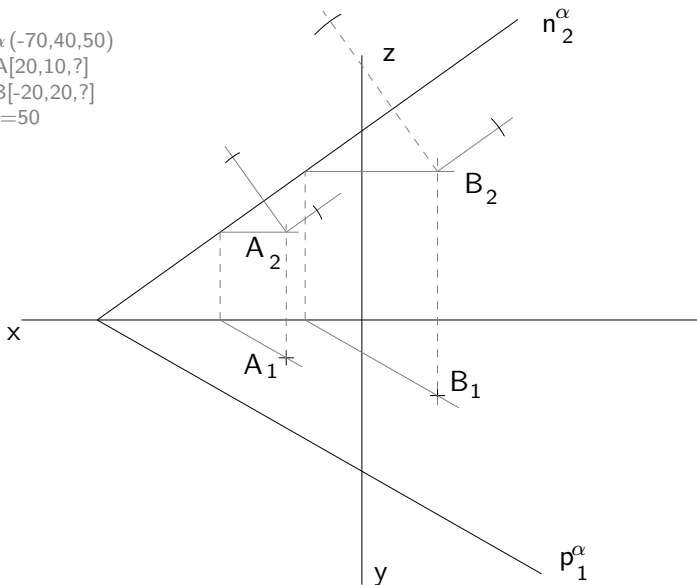

Mongeovo promítání - jehlan

$\alpha(-70,40,50)$
 $A[20,10,?]$
 $B[-20,20,?]$
 $v=50$

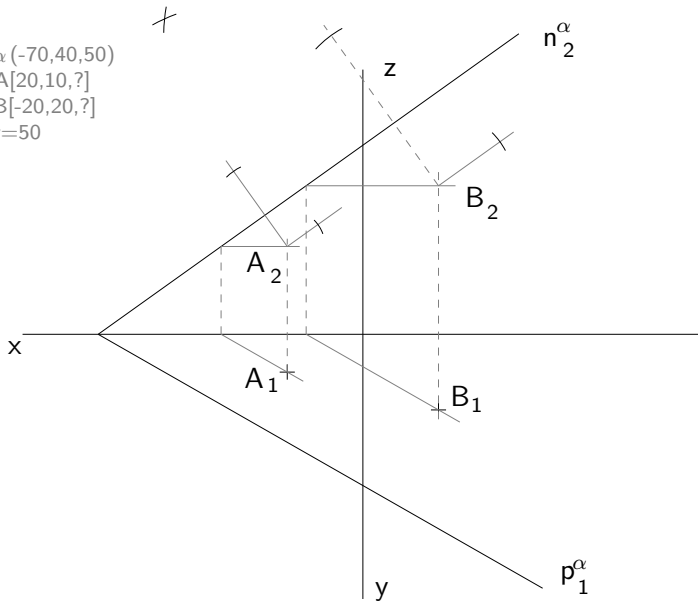

Mongeovo promítání - jehlan

$\alpha (-70,40,50)$
 $A[20,10,?]$
 $B[-20,20,?]$
 $v=50$

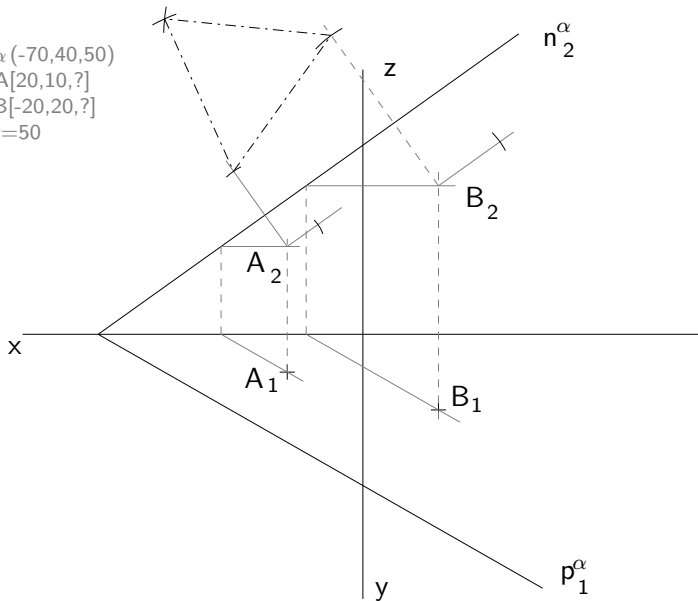

Mongeovo promítání - jehlan

$\alpha (-70,40,50)$
 $A[20,10,?]$
 $B[-20,20,?]$
 $v=50$

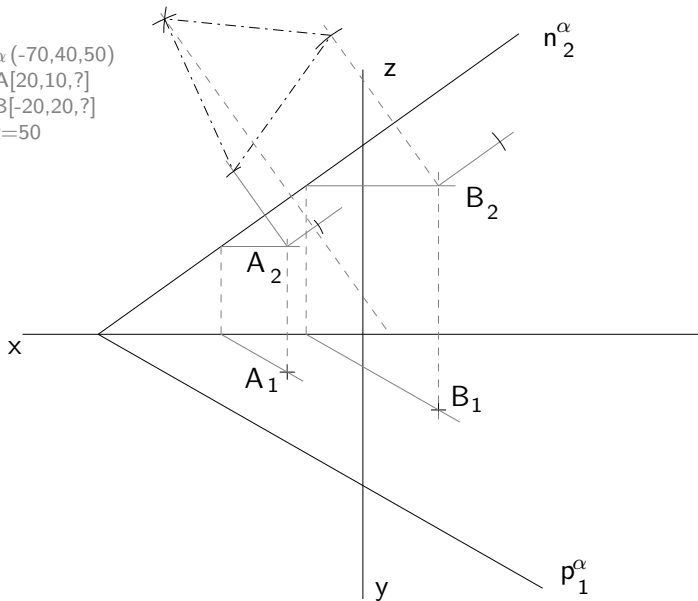

Mongeovo promítání - jehlan

$\alpha(-70,40,50)$
 $A[20,10,?]$
 $B[-20,20,?]$
 $v=50$

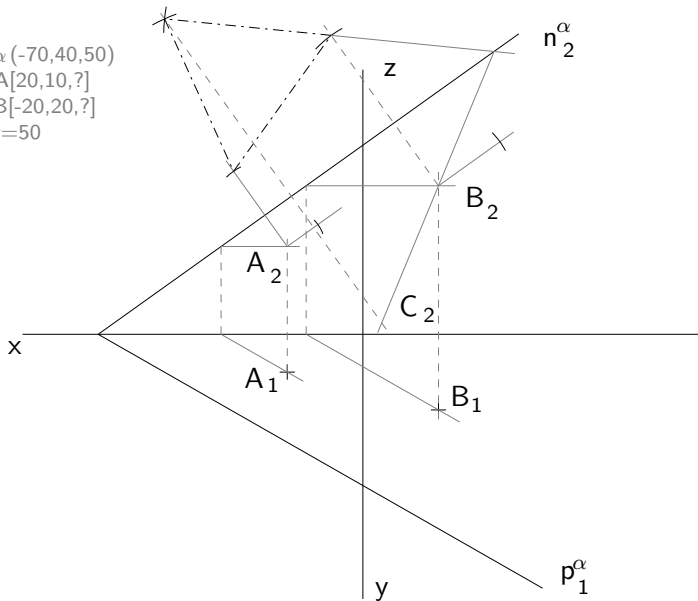

Mongeovo promítání - jehlan

$\alpha(-70,40,50)$
 $A[20,10,?]$
 $B[-20,20,?]$
 $v=50$

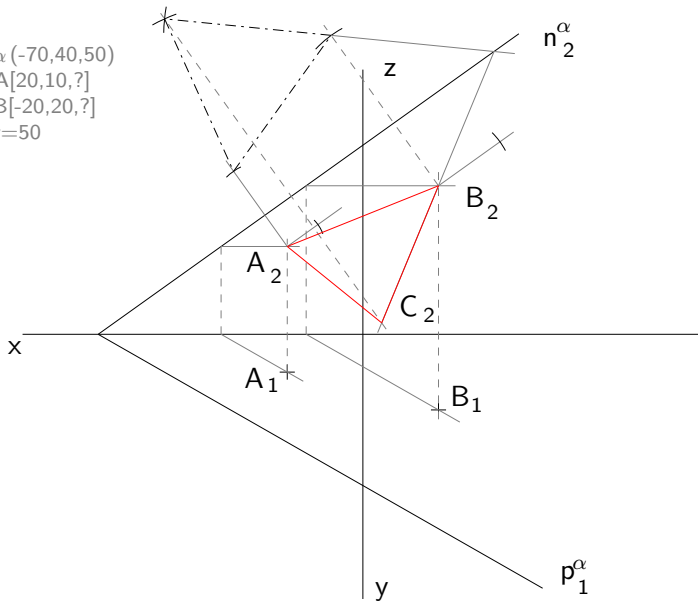

Mongeovo promítání - jehlan

$\alpha(-70,40,50)$
 $A[20,10,?]$
 $B[-20,20,?]$
 $v=50$

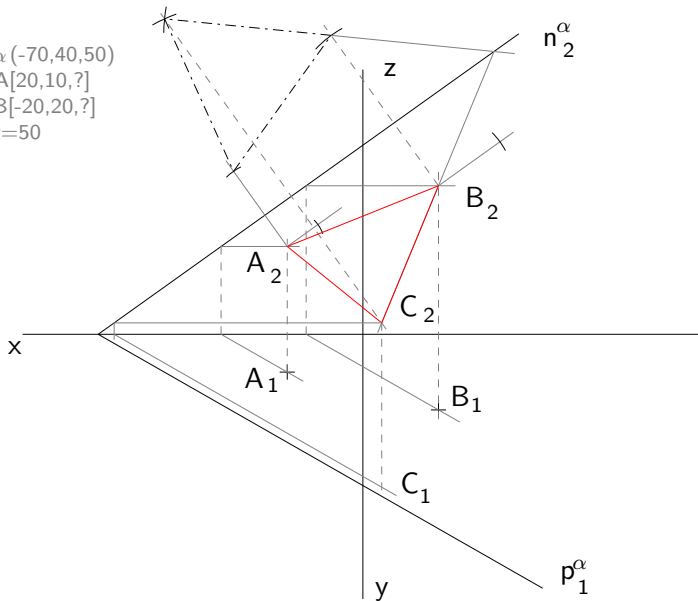

Mongeovo promítání - jehlan

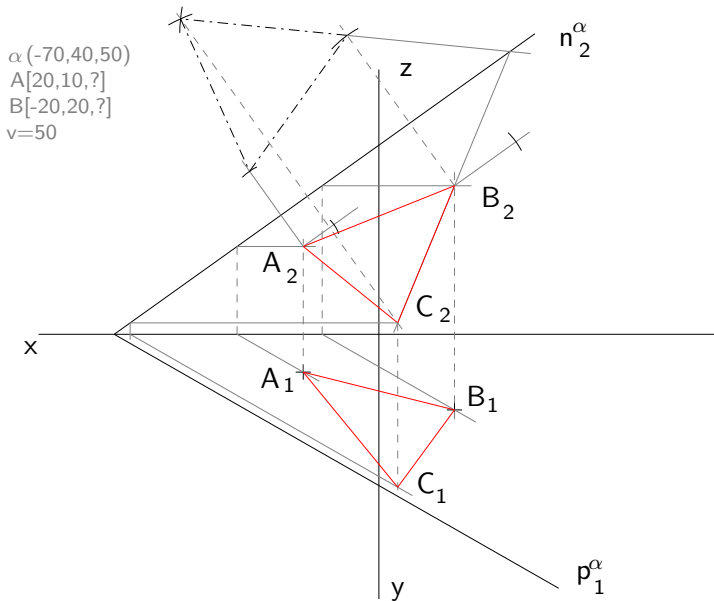

Mongeovo promítání - jehlan

$\alpha(-70,40,50)$
 $A[20,10,?]$
 $B[-20,20,?]$
 $v=50$

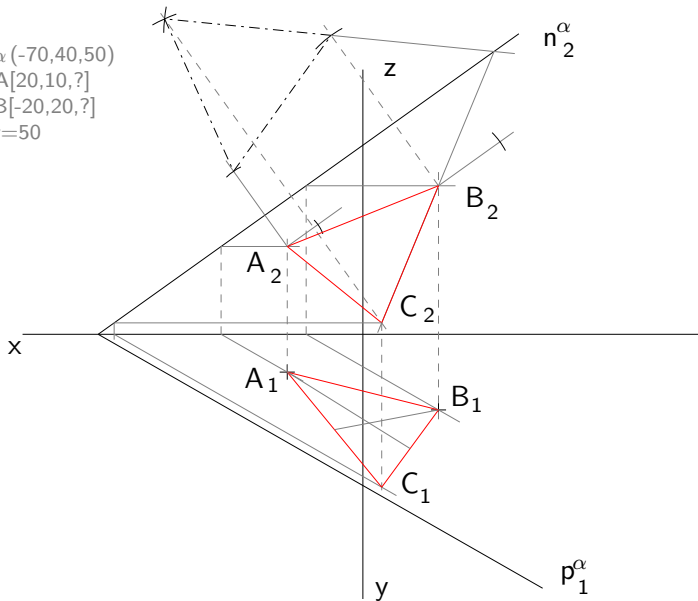

Mongeovo promítání - jehlan

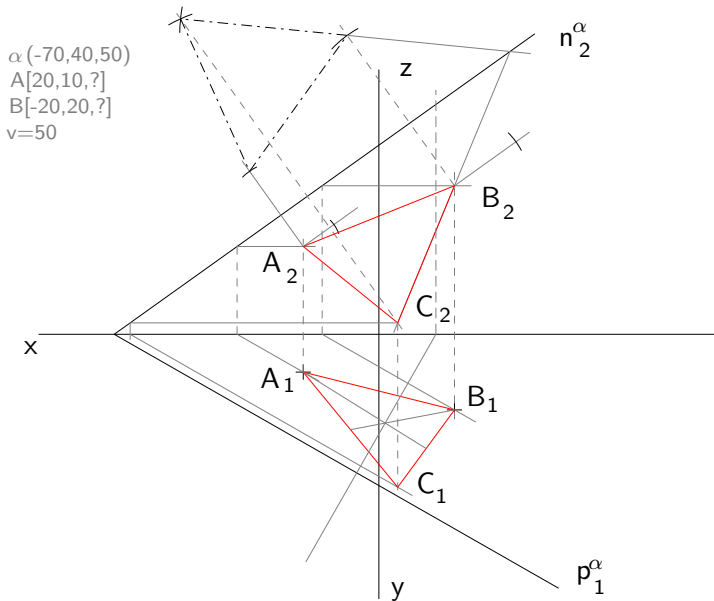

Mongeovo promítání - jehlan

$\alpha(-70,40,50)$
 $A[20,10,?]$
 $B[-20,20,?]$
 $v=50$

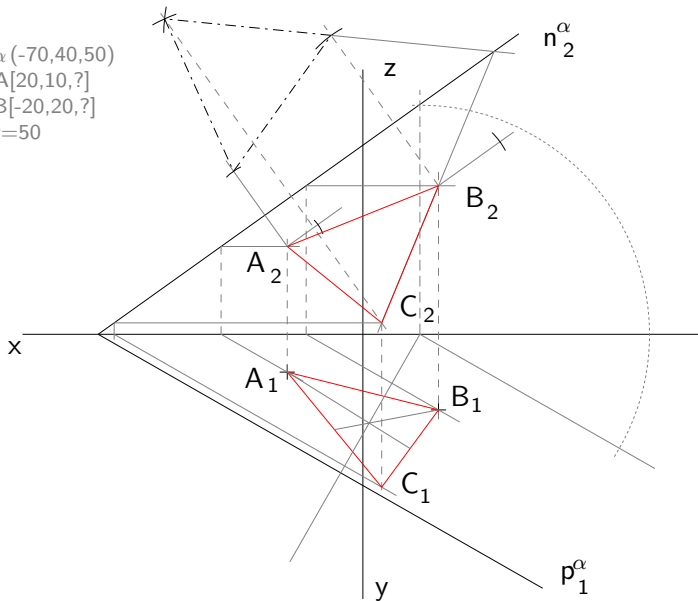

Mongeovo promítání - jehlan

$\alpha(-70,40,50)$
 $A[20,10,?]$
 $B[-20,20,?]$
 $v=50$

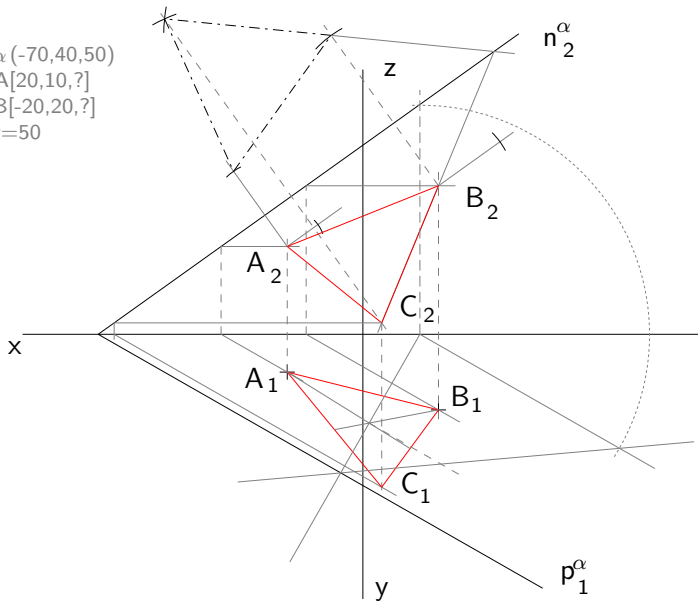

Mongeovo promítání - jehlan

$\alpha(-70,40,50)$
 $A[20,10,?]$
 $B[-20,20,?]$
 $v=50$

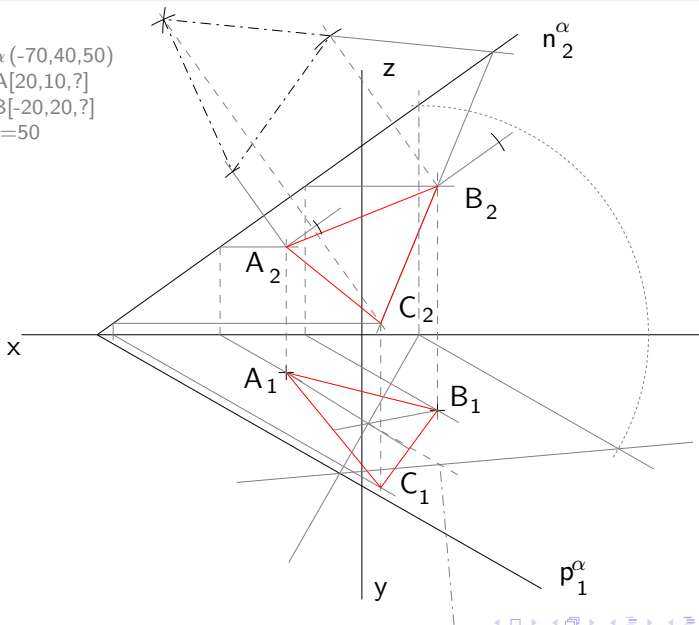

Mongeovo promítání - jehlan

$\alpha(-70,40,50)$
 $A[20,10,?]$
 $B[-20,20,?]$
 $v=50$

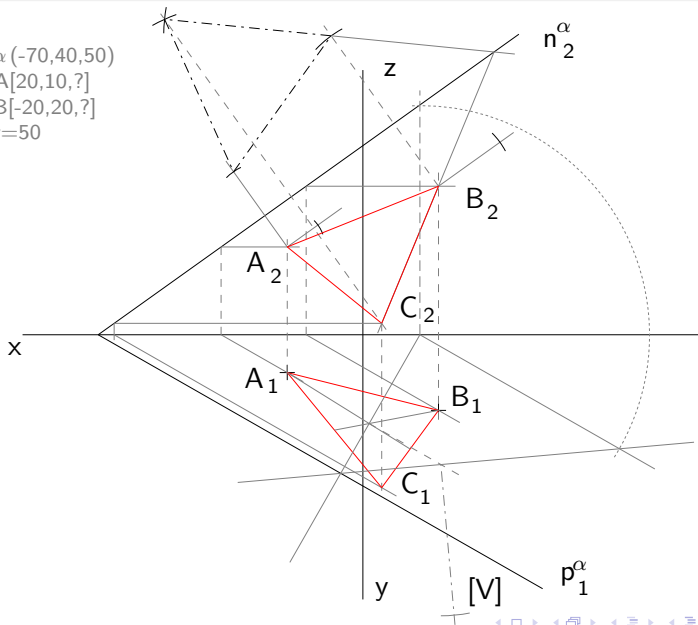

Mongeovo promítání - jehlan

$\alpha(-70,40,50)$
A[20,10,?]
B[-20,20,?]
 $v=50$

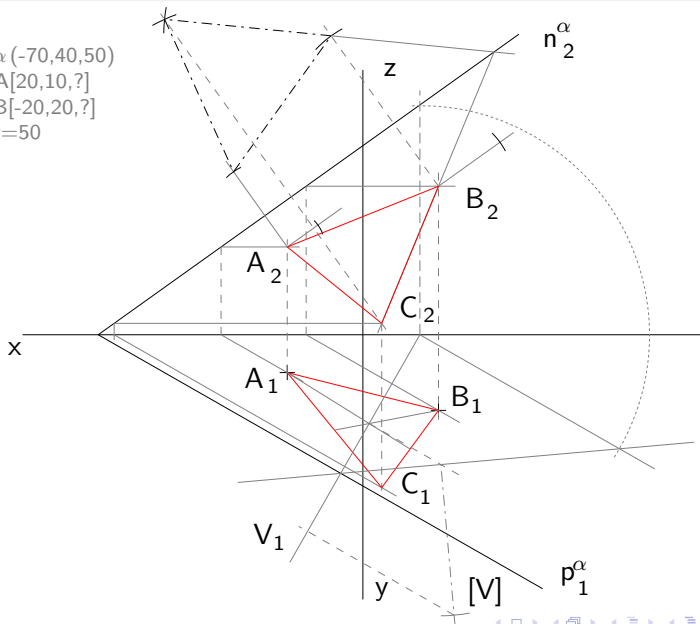

Mongeovo promítání - jehlan

$\alpha(-70, 40, 50)$
 $A[20, 10, ?]$
 $B[-20, 20, ?]$
 $v=50$

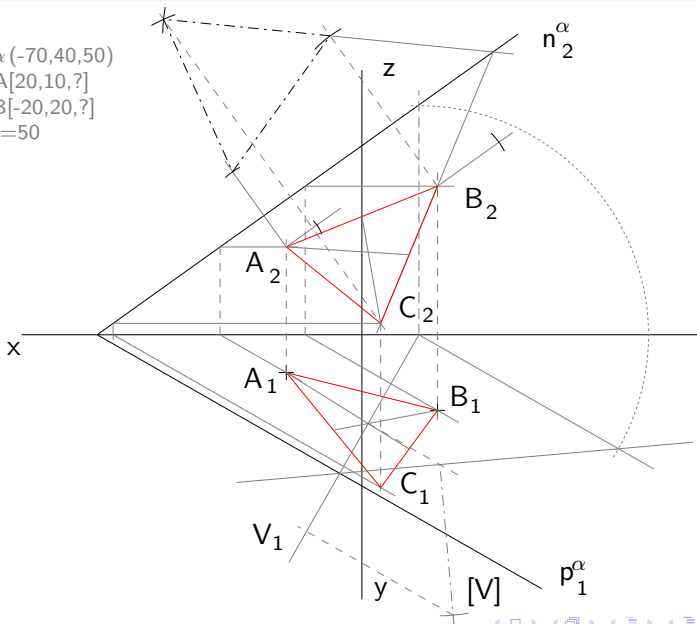

Mongeovo promítání - jehlan

$\alpha(-70,40,50)$
 $A[20,10,?]$
 $B[-20,20,?]$
 $v=50$

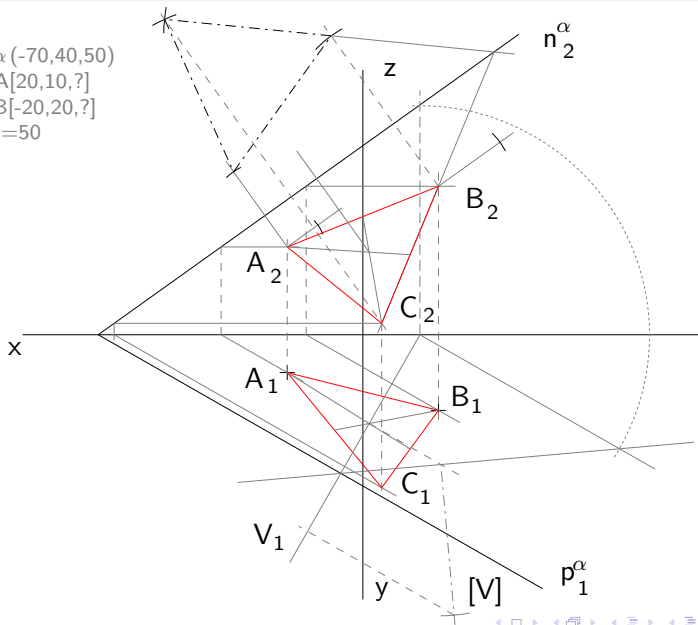

Mongeovo promítání - jehlan

$\alpha(-70,40,50)$
 $A[20,10,?]$
 $B[-20,20,?]$
 $v=50$

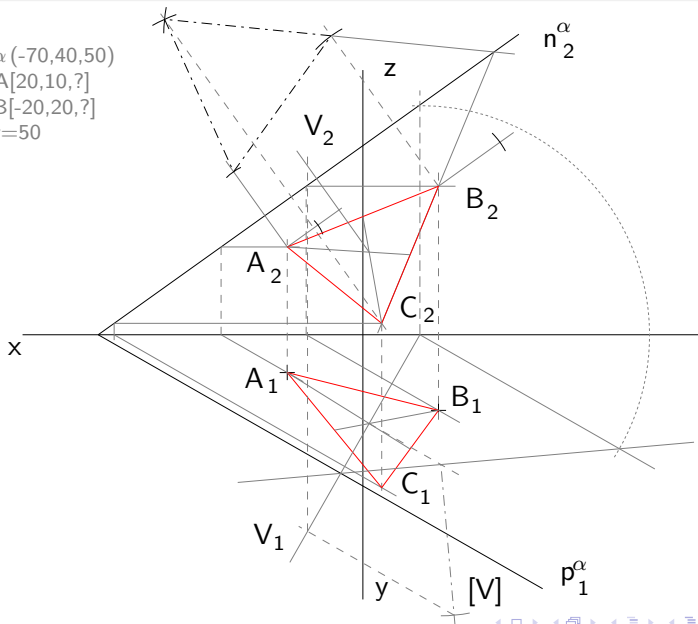

Mongeovo promítání - jehlan

$\alpha(-70,40,50)$
 $A[20,10,?]$
 $B[-20,20,?]$
 $v=50$

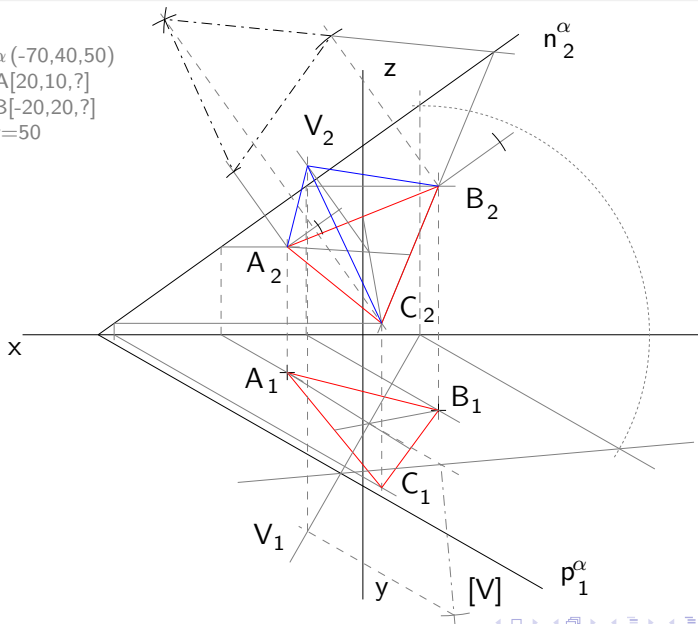

Mongeovo promítání - jehlan

$\alpha(-70,40,50)$
 $A[20,10,?]$
 $B[-20,20,?]$
 $v=50$

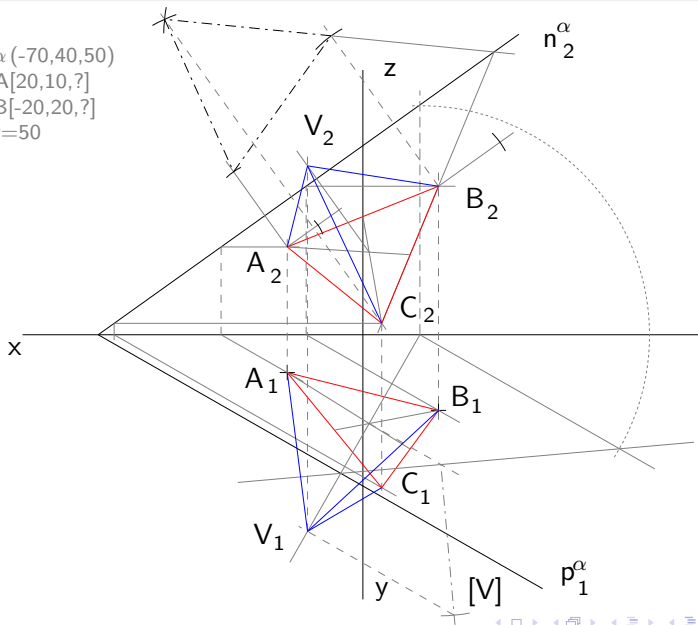

Mongeovo promítání - jehlan

$\alpha(-70,40,50)$
 $A[20,10,?]$
 $B[-20,20,?]$
 $v=50$

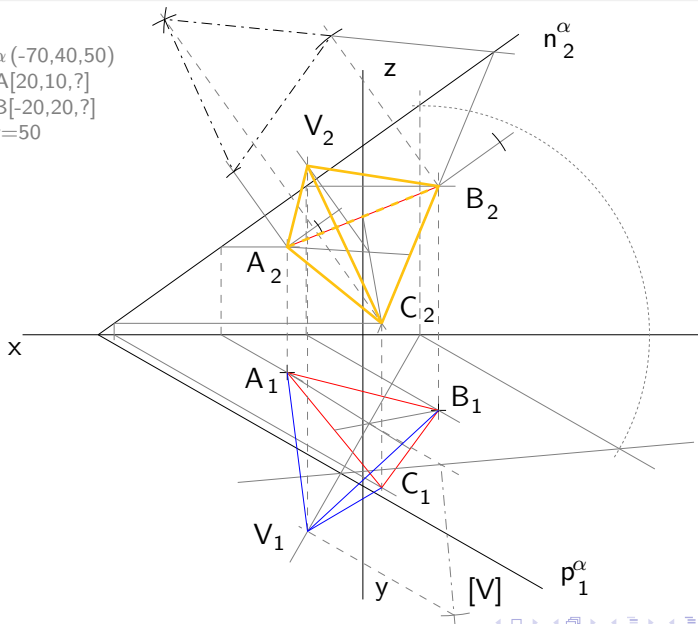

Mongeovo promítání - jehlan

$\alpha(-70,40,50)$
 $A[20,10,?]$
 $B[-20,20,?]$
 $v=50$

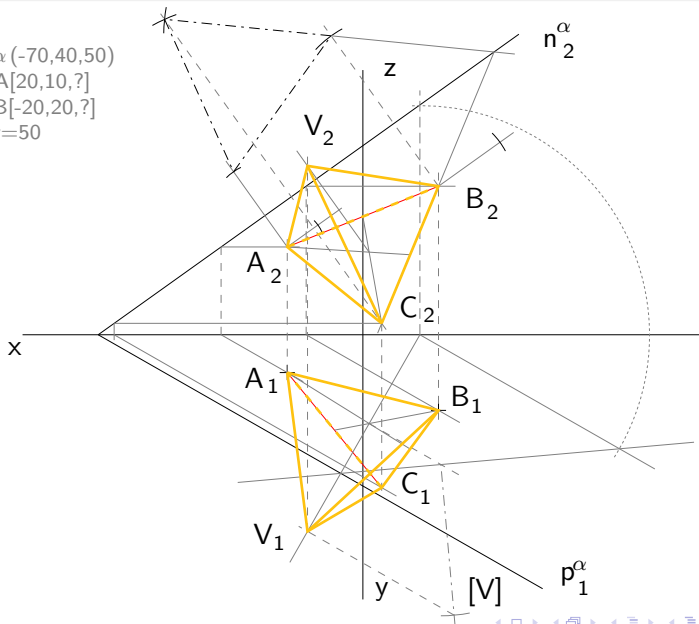

Mongeovo promítání - válec

$r=30$
 $\alpha(80,45,55)$
 $S[0,22,?]$
 $v=40$

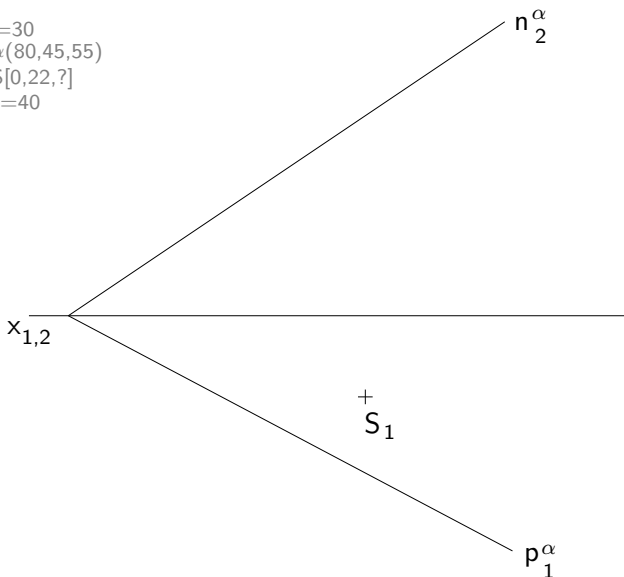

Mongeovo promítání - válec

$r=30$
 $\alpha(80,45,55)$
 $S[0,22,?]$
 $v=40$

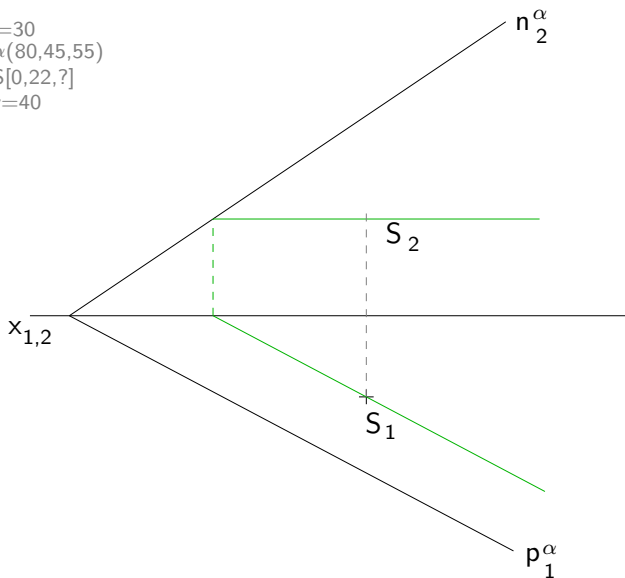

Mongeovo promítání - válec

$r=30$
 $\alpha(80,45,55)$
 $S[0,22,?]$
 $v=40$

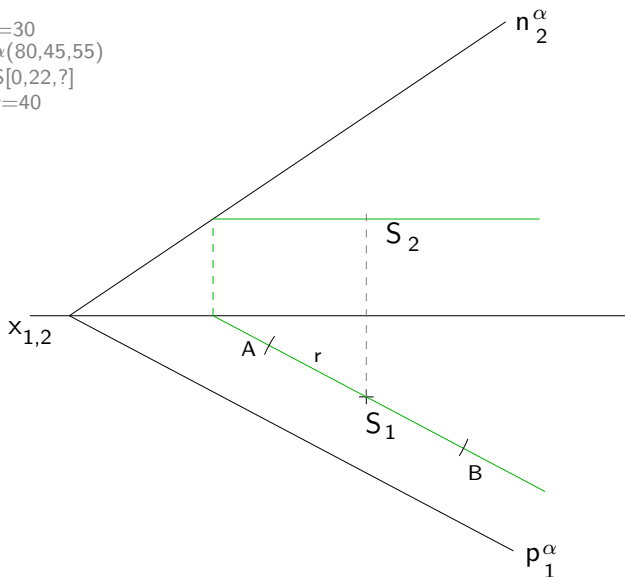

Mongeovo promítání - válec

$r=30$
 $\alpha(80,45,55)$
 $S[0,22,?]$
 $v=40$

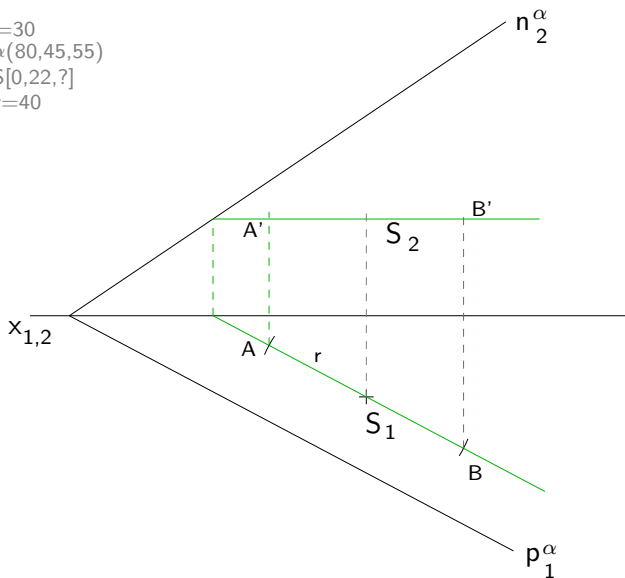

Mongeovo promítání - válec

$r=30$
 $\alpha(80,45,55)$
 $S[0,22,?]$
 $v=40$

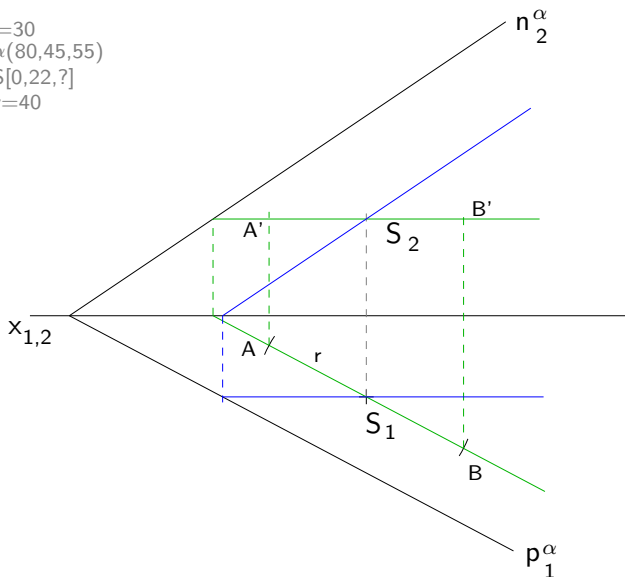

Mongeovo promítání - válec

$r=30$
 $\alpha(80,45,55)$
 $S[0,22,?]$
 $v=40$

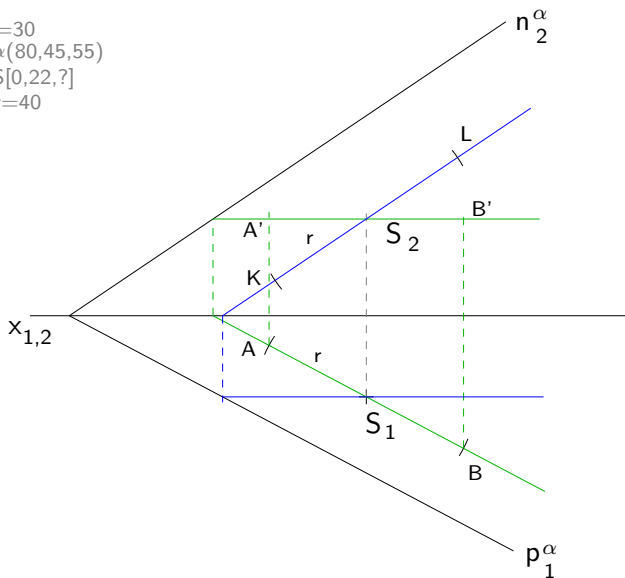

Mongeovo promítání - válec

$r=30$
 $\alpha(80,45,55)$
 $S[0,22,?]$
 $v=40$

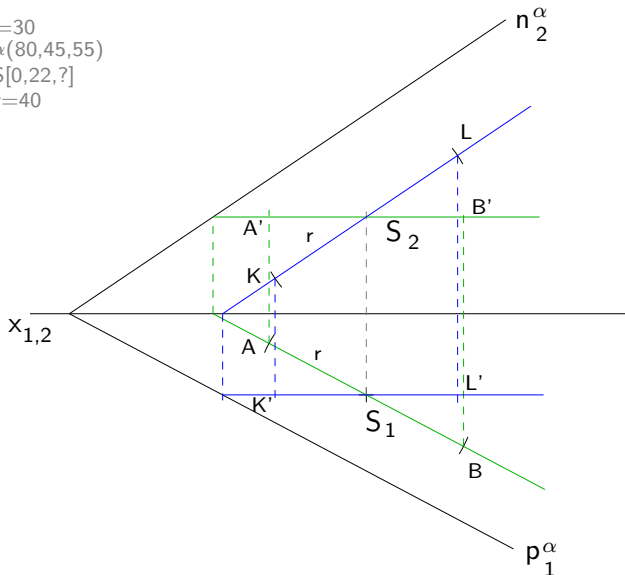

Mongeovo promítání - válec

$r=30$
 $\alpha(80,45,55)$
 $S[0,22,?]$
 $v=40$

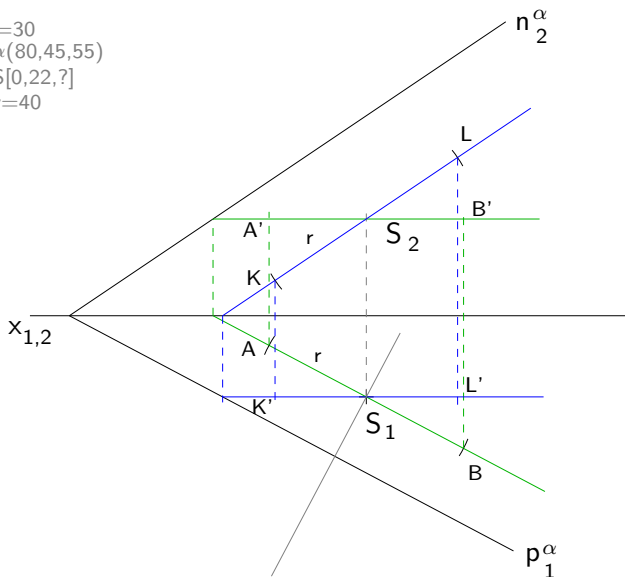

Mongeovo promítání - válec

$r=30$
 $\alpha(80,45,55)$
 $S[0,22,?]$
 $v=40$

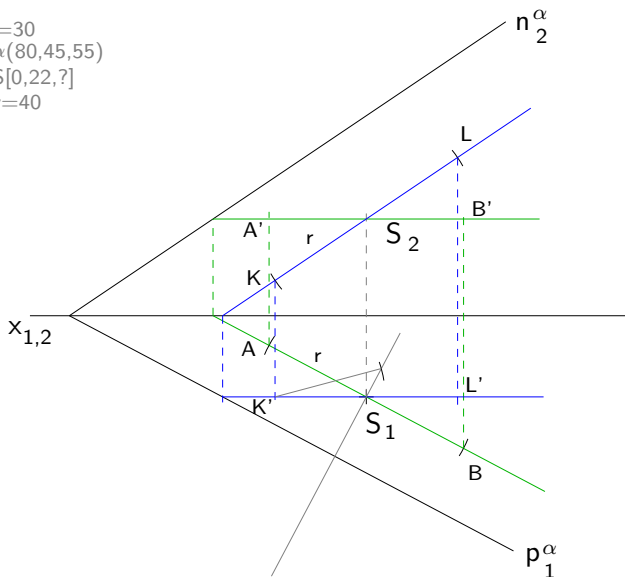

Mongeovo promítání - válec

$r=30$
 $\alpha(80,45,55)$
 $S[0,22,?]$
 $v=40$

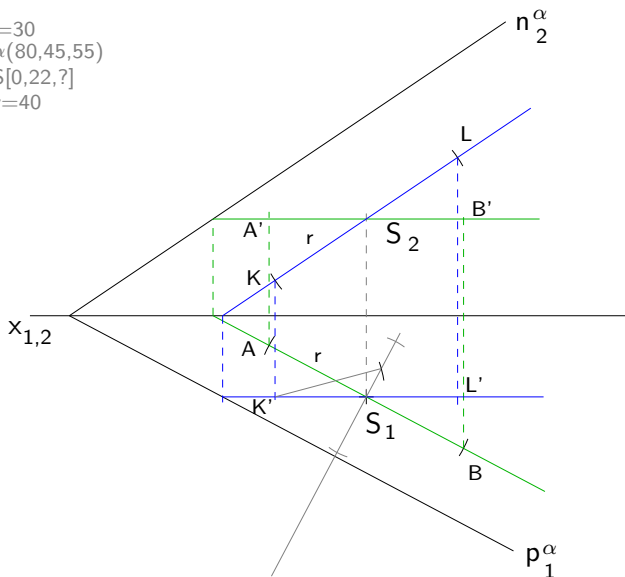

Mongeovo promítání - válec

$r=30$
 $\alpha(80,45,55)$
 $S[0,22,?]$
 $v=40$

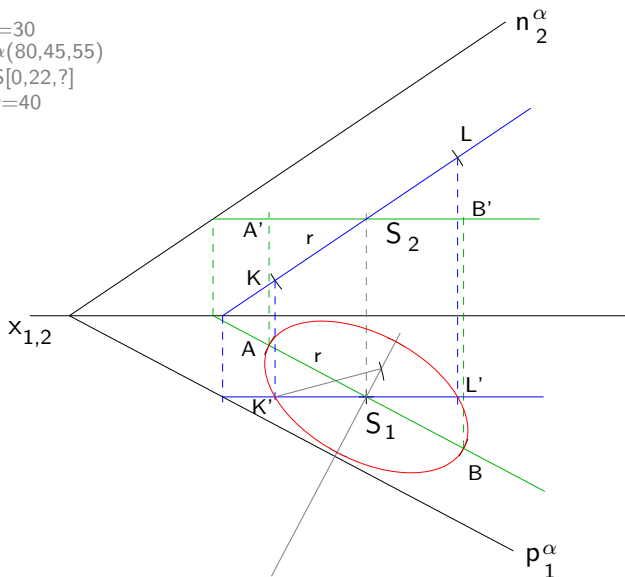

Mongeovo promítání - válec

$r=30$
 $\alpha(80,45,55)$
 $S[0,22,?]$
 $v=40$

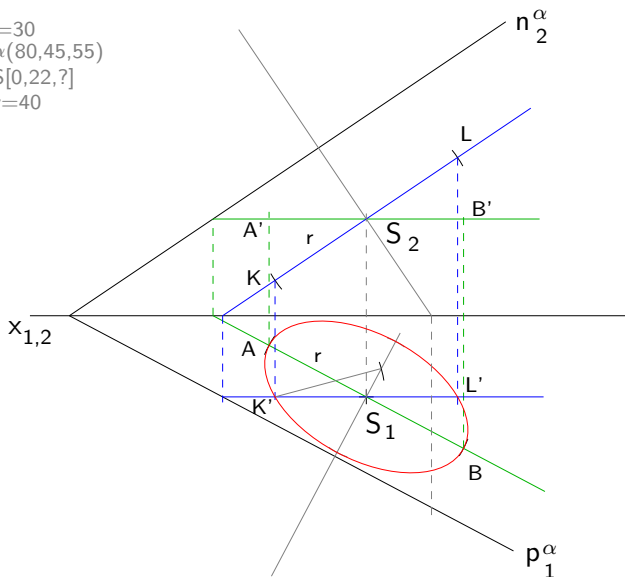

Mongeovo promítání - válec

$r=30$
 $\alpha(80,45,55)$
 $S[0,22,?]$
 $v=40$

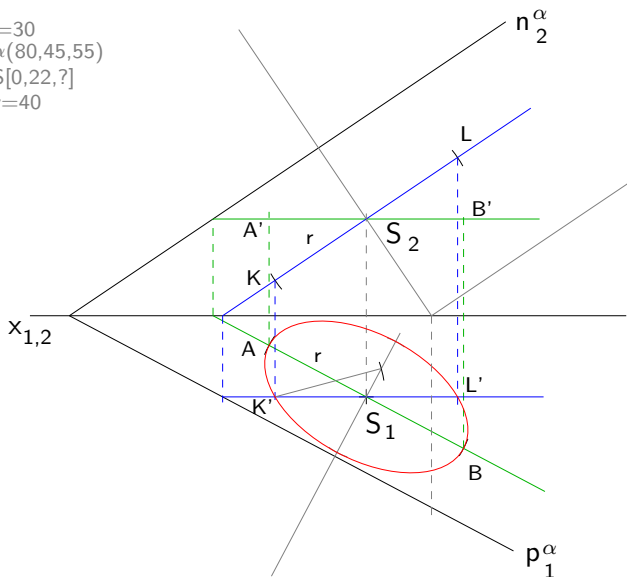

Mongeovo promítání - válec

$r=30$
 $\alpha(80,45,55)$
 $S[0,22,?]$
 $v=40$

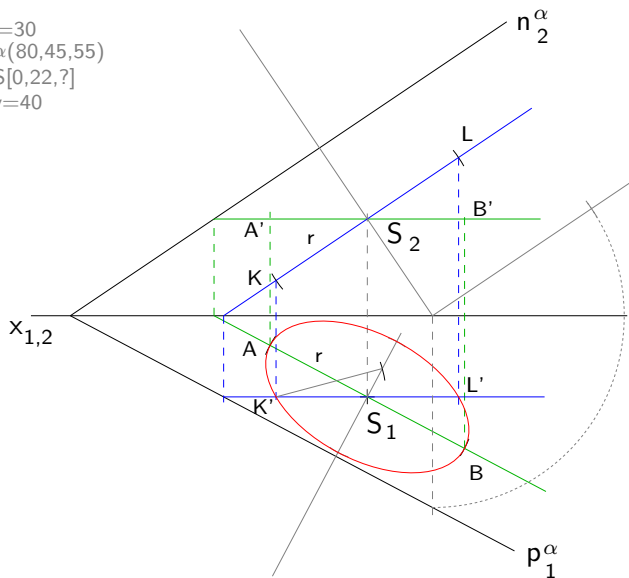

Mongeovo promítání - válec

$r=30$
 $\alpha(80,45,55)$
 $S[0,22,?]$
 $v=40$

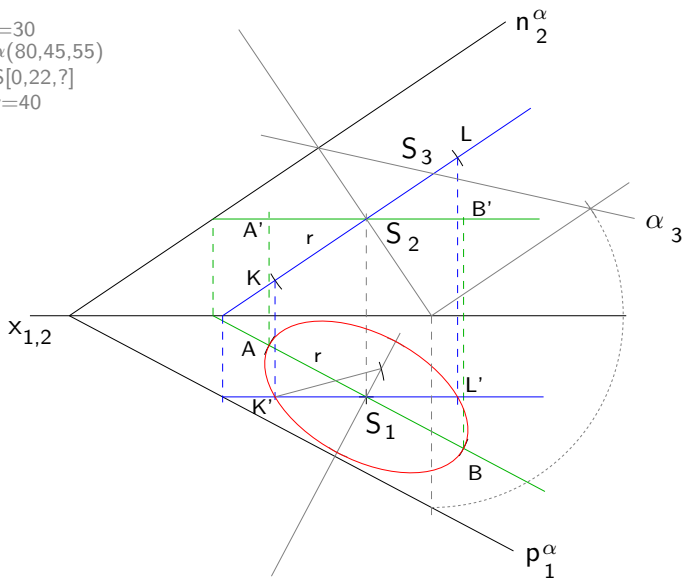

Mongeovo promítání - válec

$r=30$
 $\alpha(80,45,55)$
 $S[0,22,?]$
 $v=40$

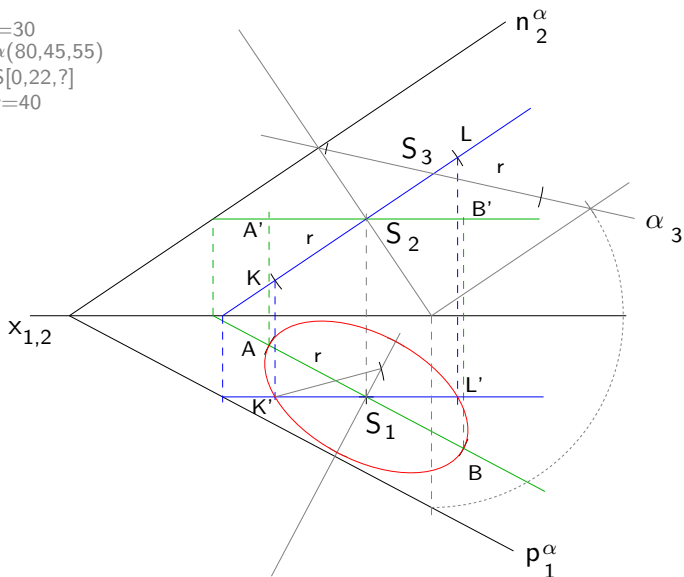

Mongeovo promítání - válec

$r=30$
 $\alpha(80,45,55)$
 $S[0,22,?]$
 $v=40$

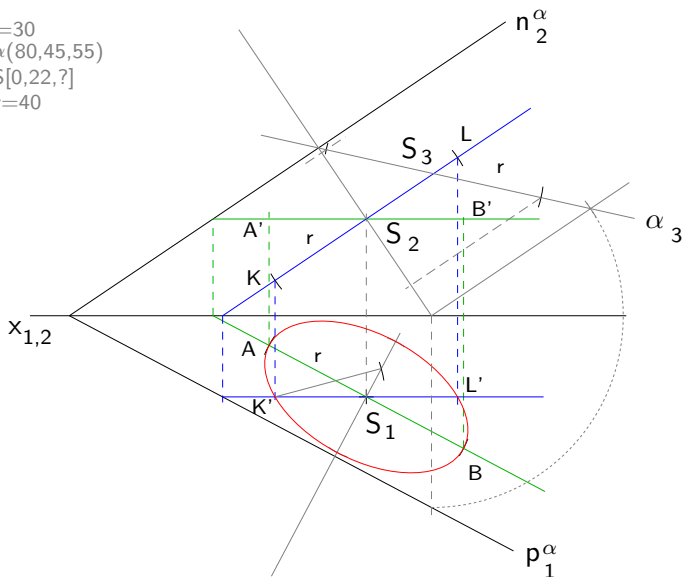

Mongeovo promítání - válec

$r=30$
 $\alpha(80,45,55)$
 $S[0,22,?]$
 $v=40$

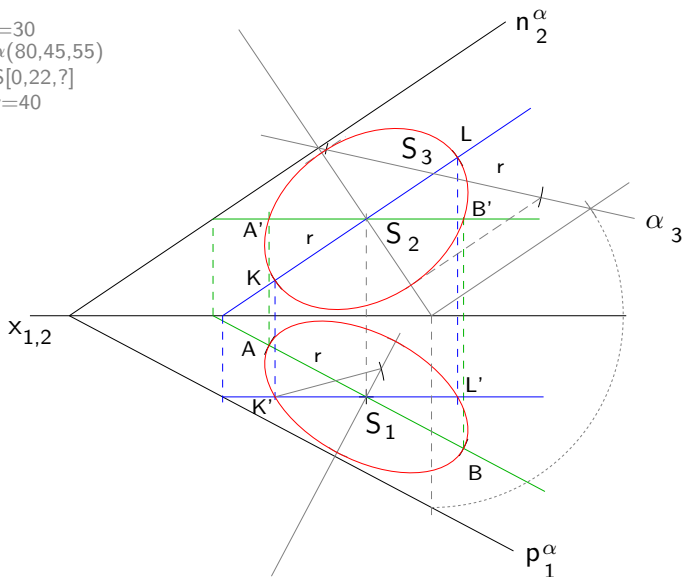

Mongeovo promítání - válec

$r=30$
 $\alpha(80,45,55)$
 $S[0,22,?]$
 $v=40$

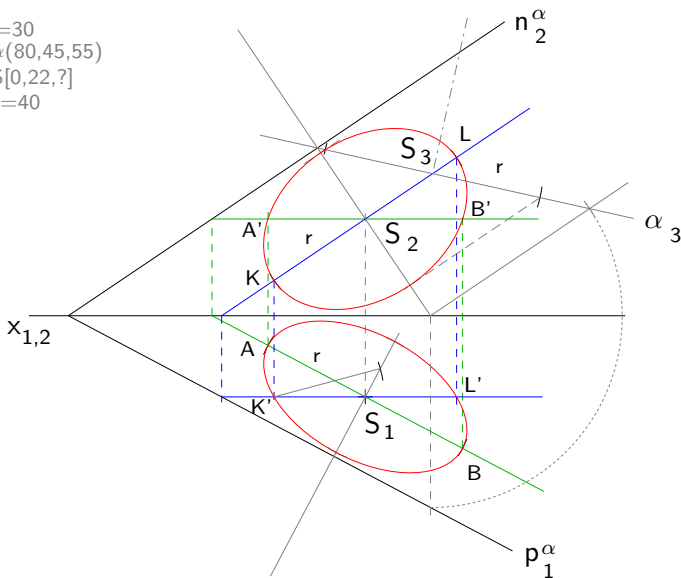

Mongeovo promítání - válec

$r=30$
 $\alpha(80,45,55)$
 $S[0,22,?]$
 $v=40$

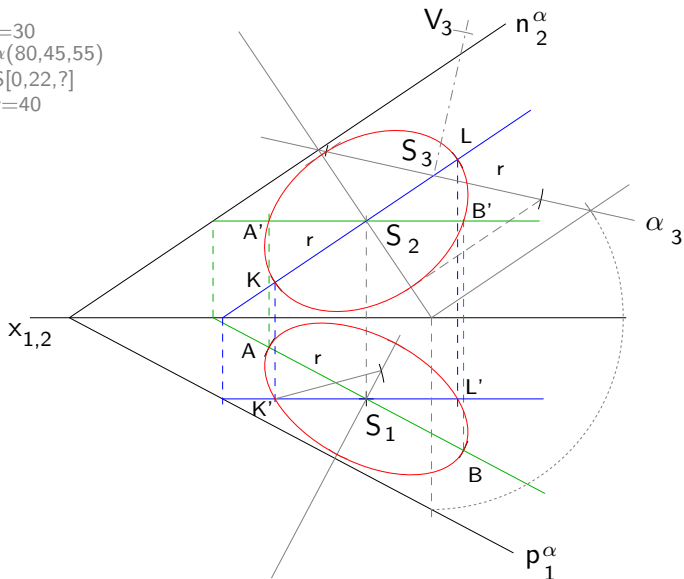

Mongeovo promítání - válec

$r=30$
 $\alpha(80,45,55)$
 $S[0,22,?]$
 $v=40$

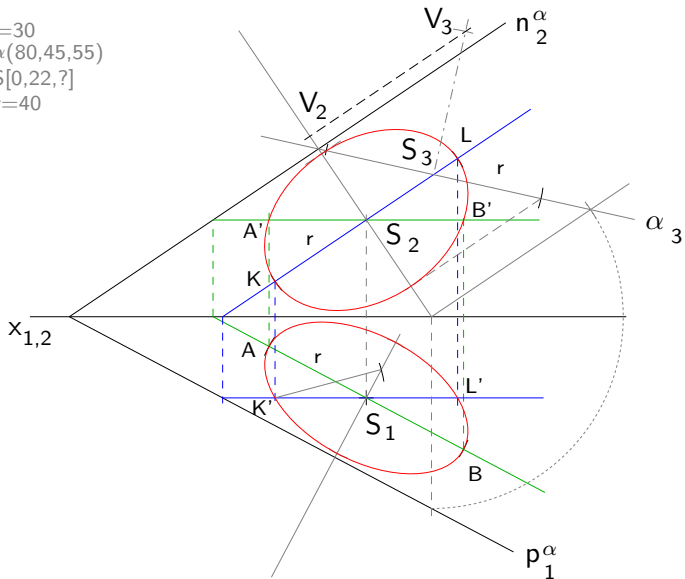

Mongeovo promítání - válec

$r=30$
 $\alpha(80,45,55)$
 $S[0,22,?]$
 $v=40$

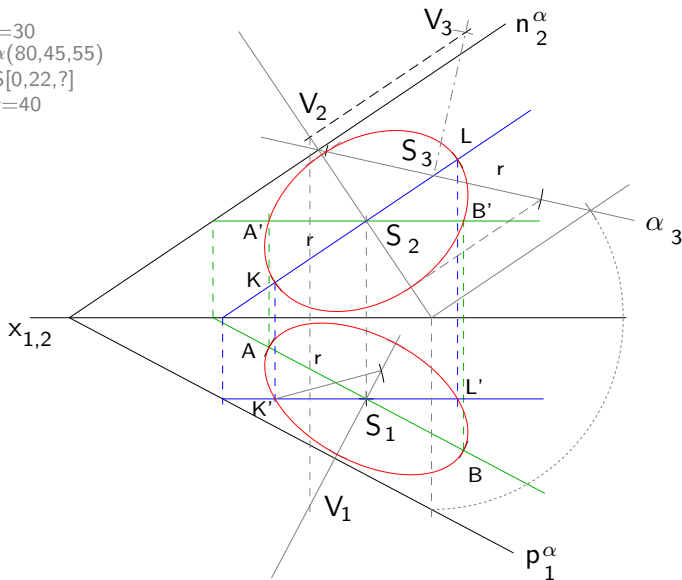

Mongeovo promítání - válec

$r=30$
 $\alpha(80,45,55)$
 $S[0,22,?]$
 $v=40$

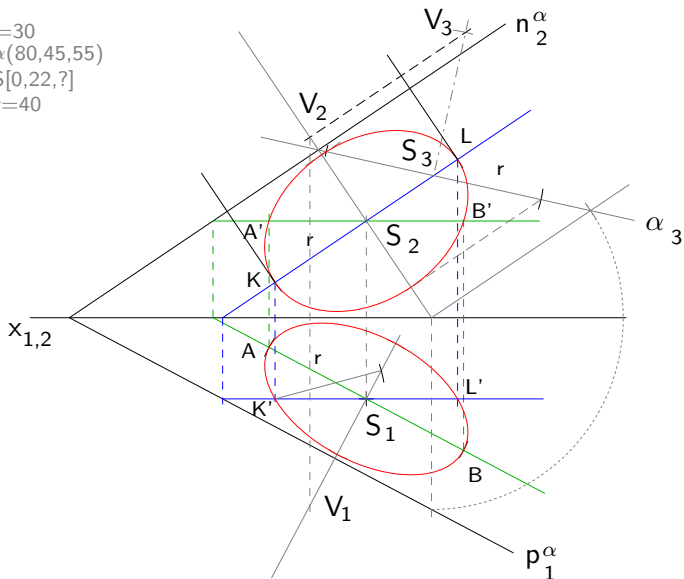

Mongeovo promítání - válec

$r=30$
 $\alpha(80,45,55)$
 $S[0,22,?]$
 $v=40$

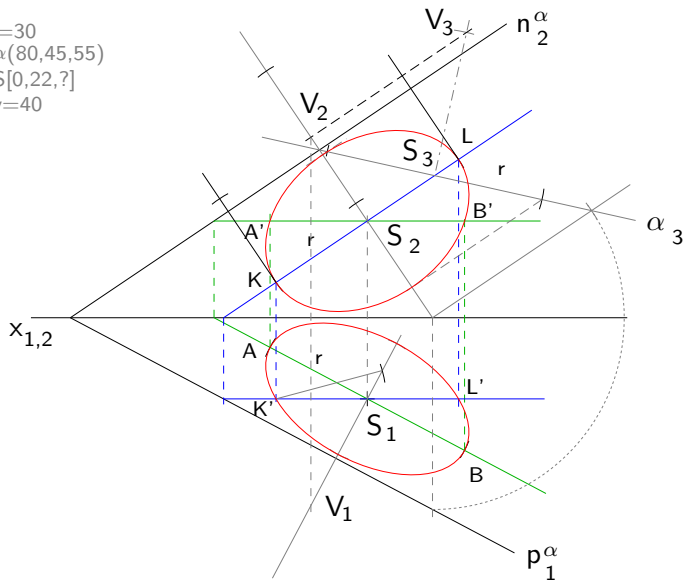

Mongeovo promítání - válec

$r=30$
 $\alpha(80,45,55)$
 $S[0,22,?]$
 $v=40$

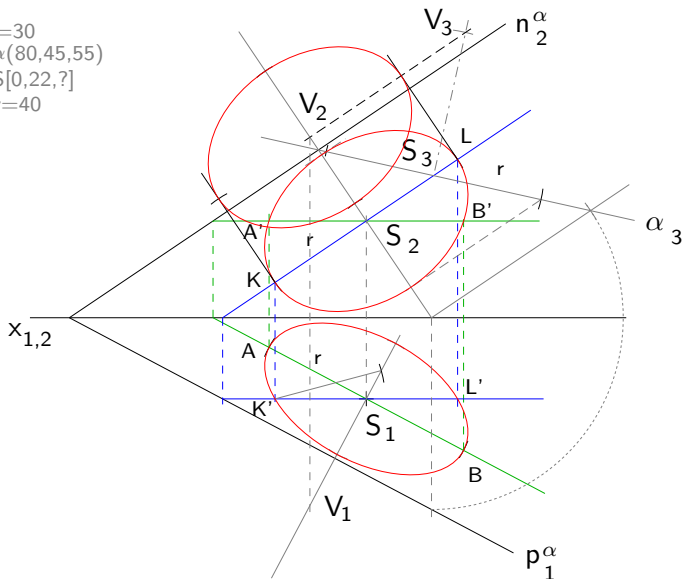

Mongeovo promítání - válec

$r=30$
 $\alpha(80,45,55)$
 $S[0,22,?]$
 $v=40$

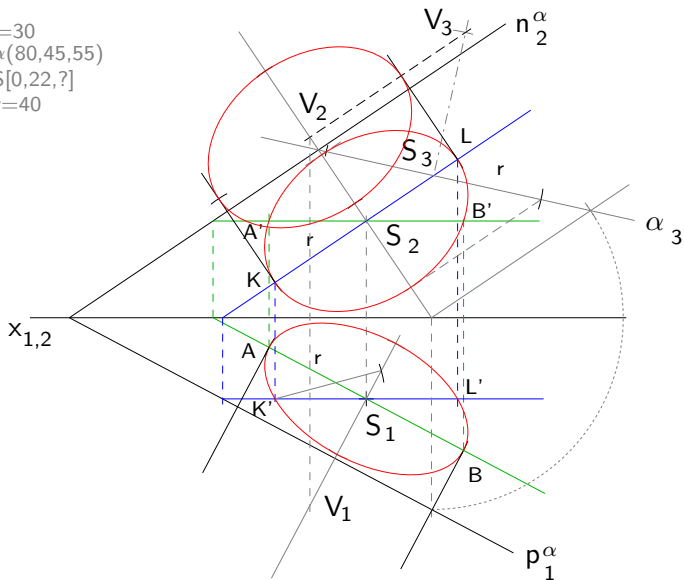

Mongeovo promítání - válec

$r=30$
 $\alpha(80,45,55)$
 $S[0,22,?]$
 $v=40$

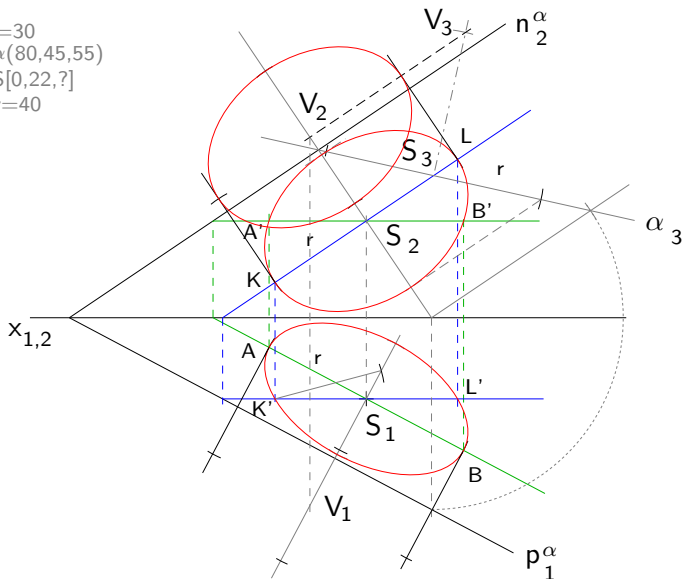

Mongeovo promítání - válec

$r=30$
 $\alpha(80,45,55)$
 $S[0,22,?]$
 $v=40$

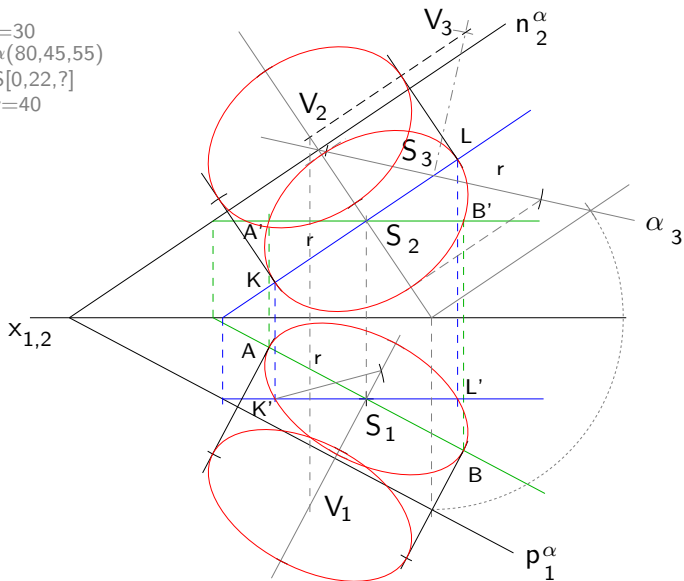

Mongeovo promítání - válec

$r=30$
 $\alpha(80,45,55)$
 $S[0,22,?]$
 $v=40$

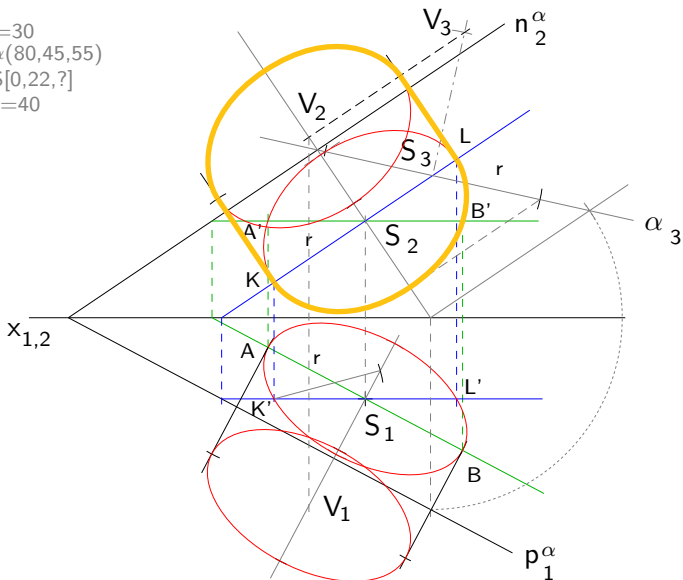

Mongeovo promítání - válec

$r=30$
 $\alpha(80,45,55)$
 $S[0,22,?]$
 $v=40$

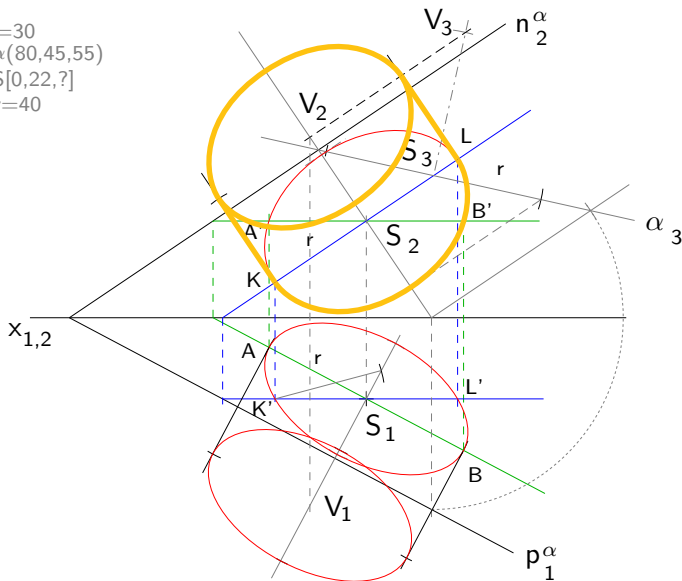

Mongeovo promítání - válec

$r=30$
 $\alpha(80,45,55)$
 $S[0,22,?]$
 $v=40$

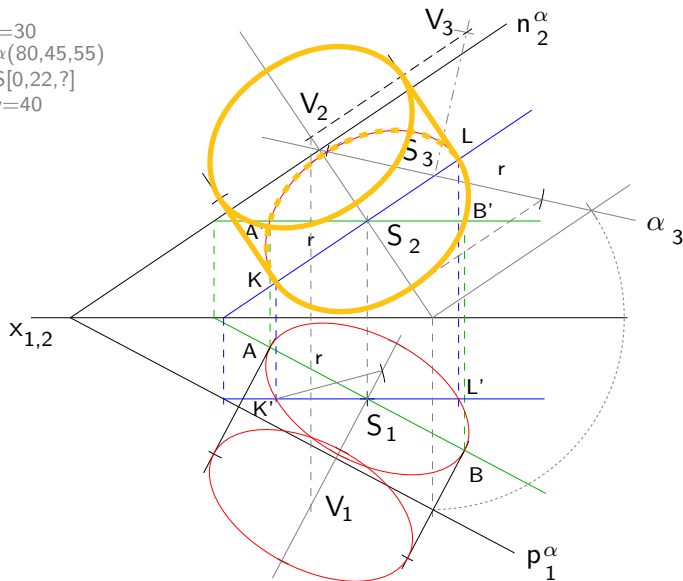

Mongeovo promítání - válec

$r=30$
 $\alpha(80,45,55)$
 $S[0,22,?]$
 $v=40$

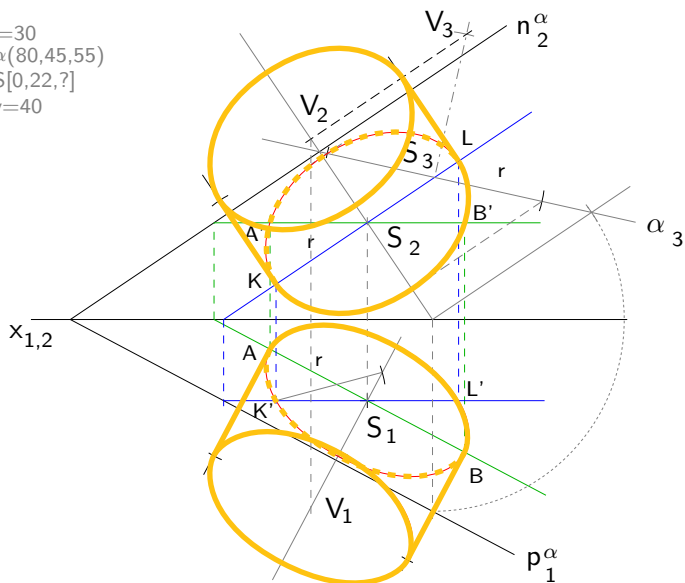

Kolmá axonometrie - krychle

XYZ(100,120,110)

A[15,0,15]

C[90,0,45]

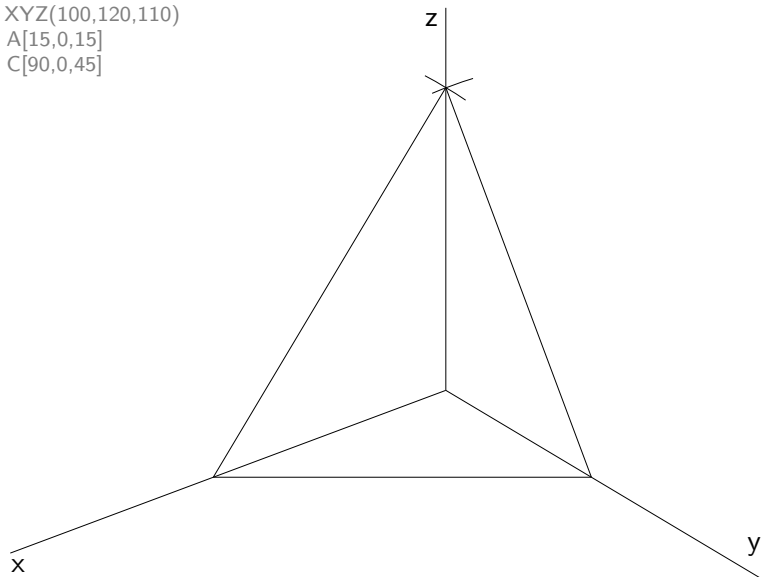

Kolmá axonometrie - krychle

XYZ(100,120,110)

A[15,0,15]

C[90,0,45]

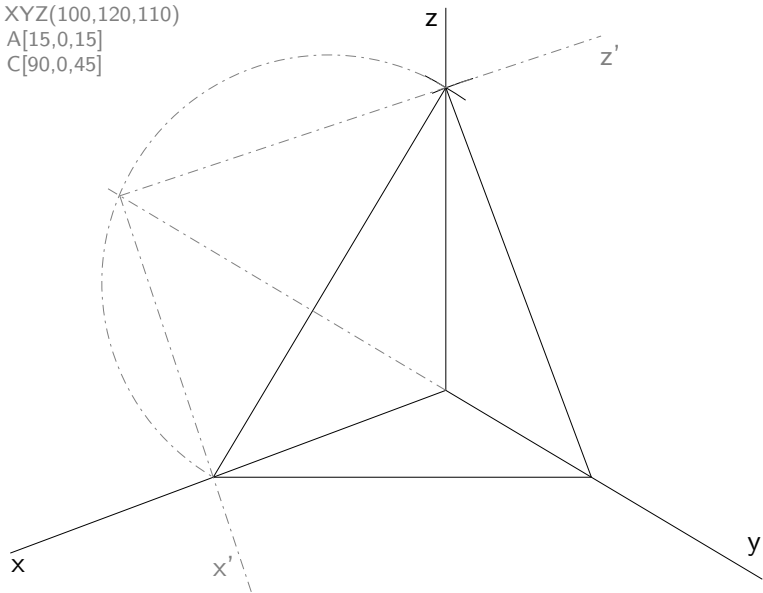

Kolmá axonometrie - krychle

XYZ(100,120,110)

A[15,0,15]

C[90,0,45]

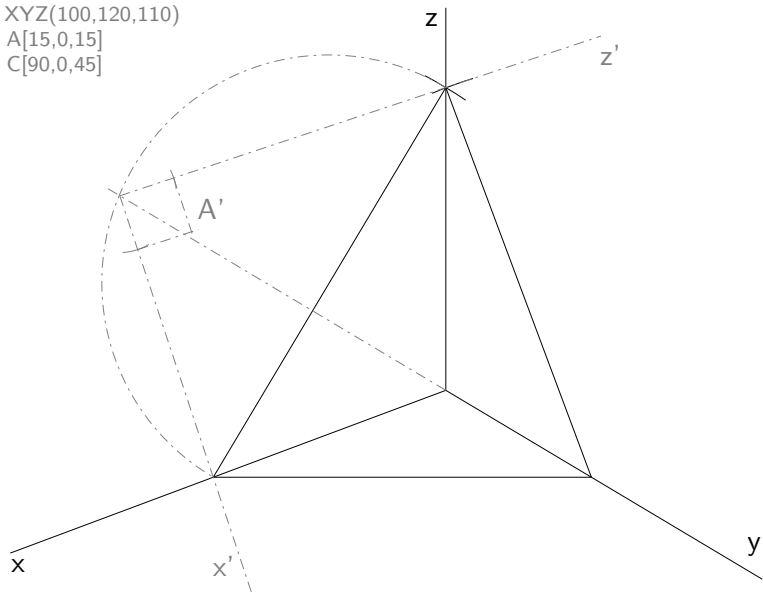

Kolmá axonometrie - krychle

XYZ(100,120,110)

A[15,0,15]

C[90,0,45]

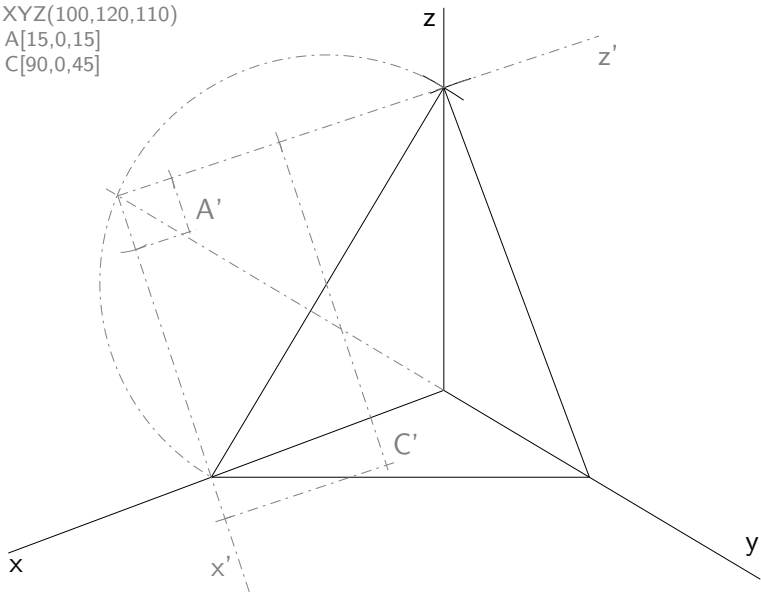

Kolmá axonometrie - krychle

XYZ(100,120,110)

A[15,0,15]

C[90,0,45]

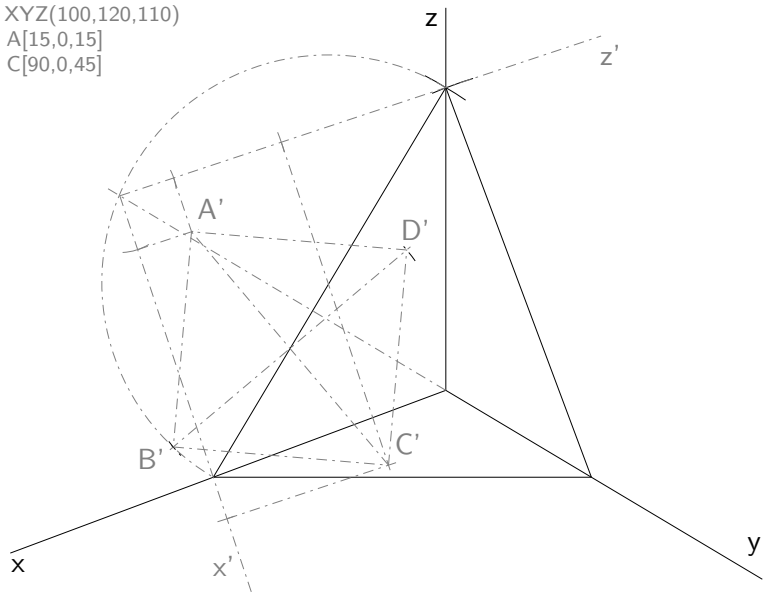

Kolmá axonometrie - krychle

XYZ(100,120,110)

A[15,0,15]

C[90,0,45]

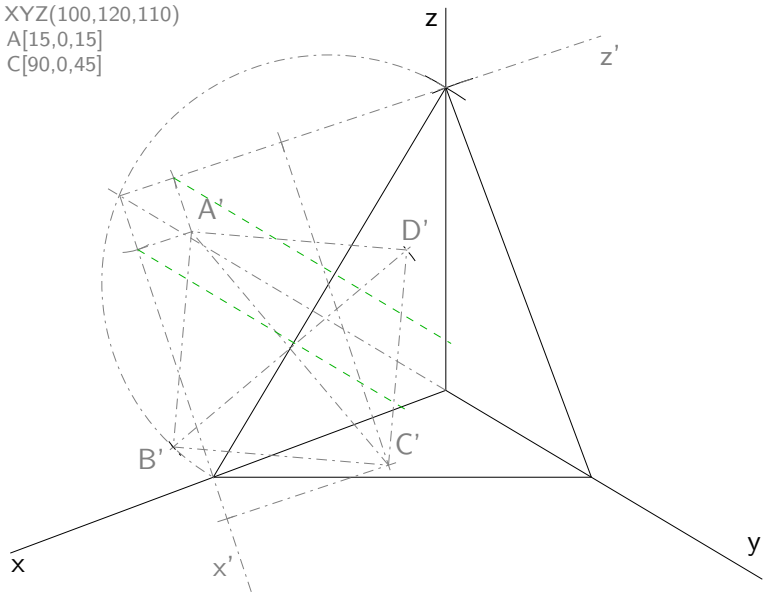

Kolmá axonometrie - krychle

XYZ(100,120,110)

A[15,0,15]

C[90,0,45]

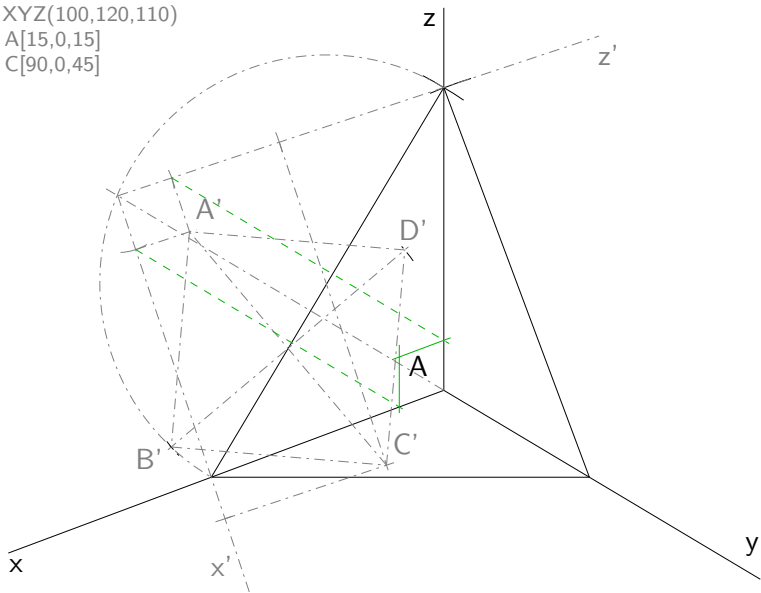

Kolmá axonometrie - krychle

XYZ(100,120,110)

A[15,0,15]

C[90,0,45]

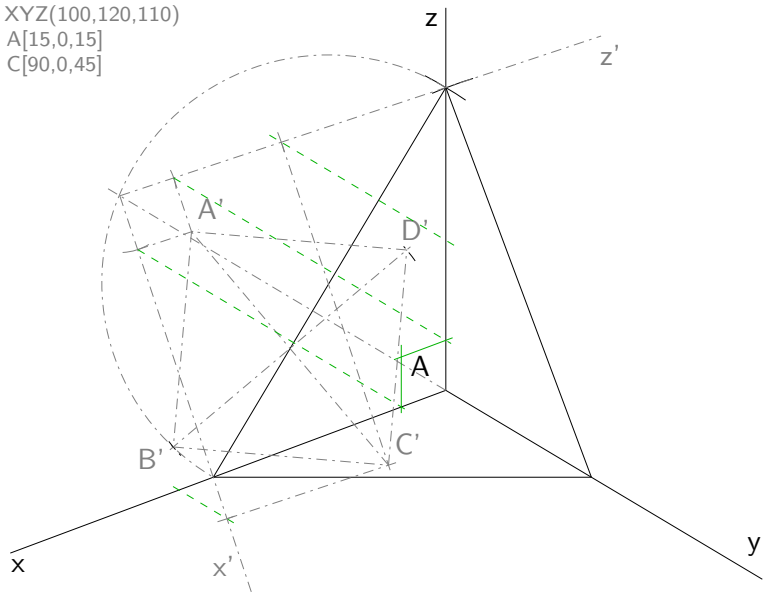

Kolmá axonometrie - krychle

XYZ(100,120,110)

A[15,0,15]

C[90,0,45]

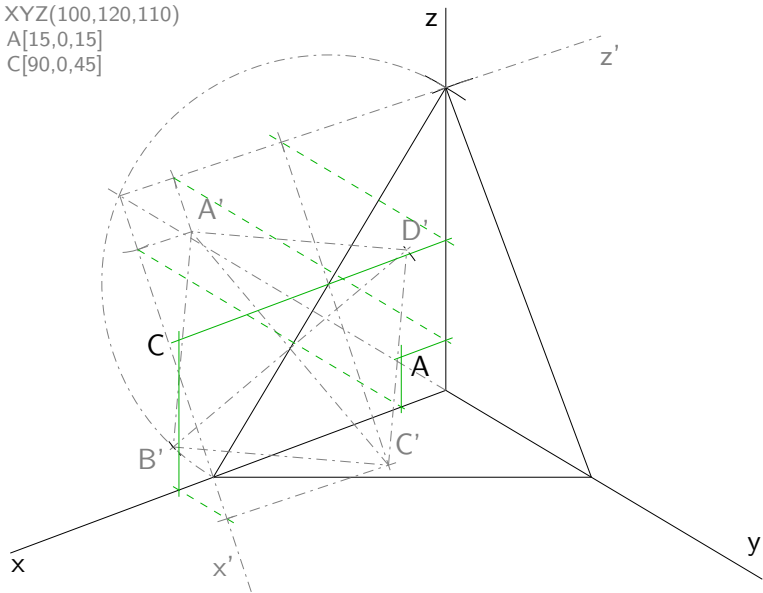

Kolmá axonometrie - krychle

XYZ(100,120,110)

A[15,0,15]

C[90,0,45]

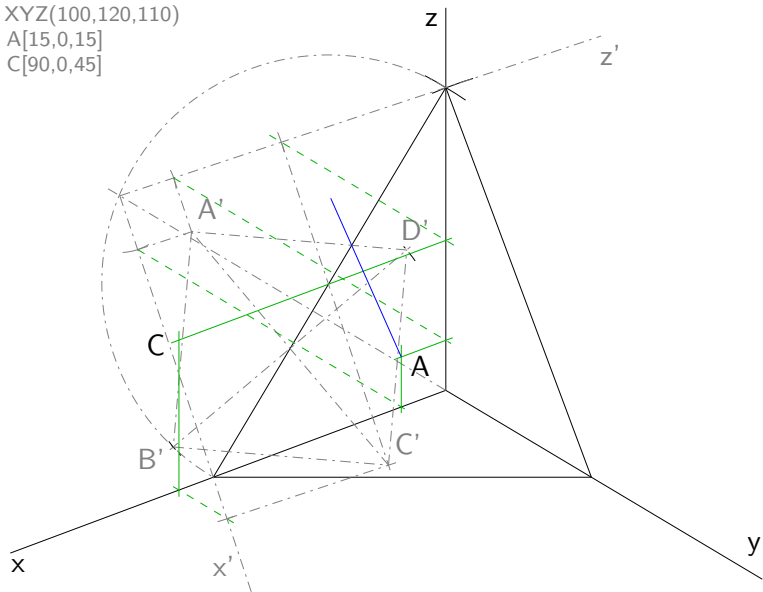

Kolmá axonometrie - krychle

XYZ(100,120,110)

A[15,0,15]

C[90,0,45]

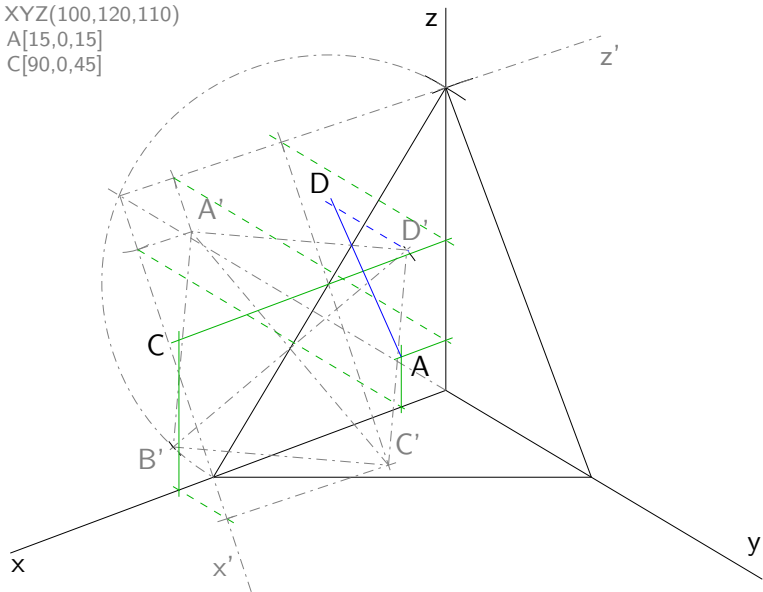

Kolmá axonometrie - krychle

XYZ(100,120,110)

A[15,0,15]

C[90,0,45]

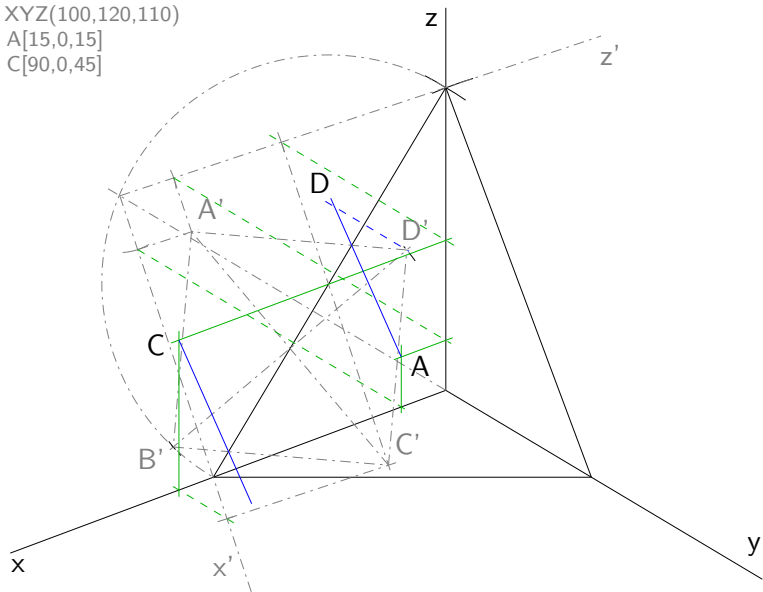

Kolmá axonometrie - krychle

XYZ(100,120,110)

A[15,0,15]

C[90,0,45]

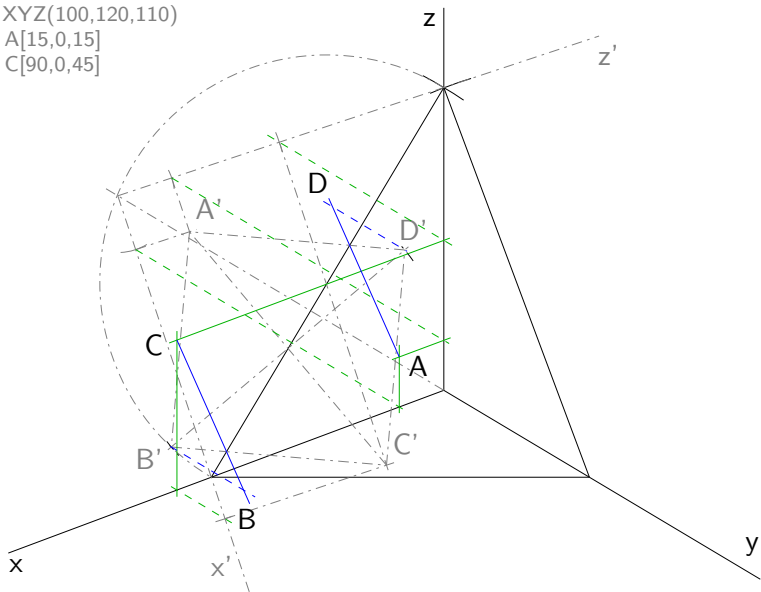

Kolmá axonometrie - krychle

XYZ(100,120,110)

A[15,0,15]

C[90,0,45]

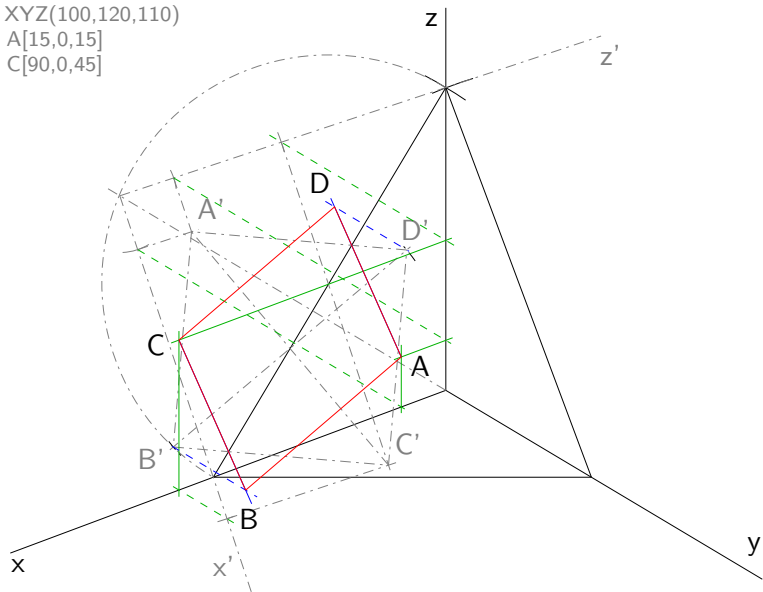

Kolmá axonometrie - krychle

XYZ(100,120,110)

A[15,0,15]

C[90,0,45]

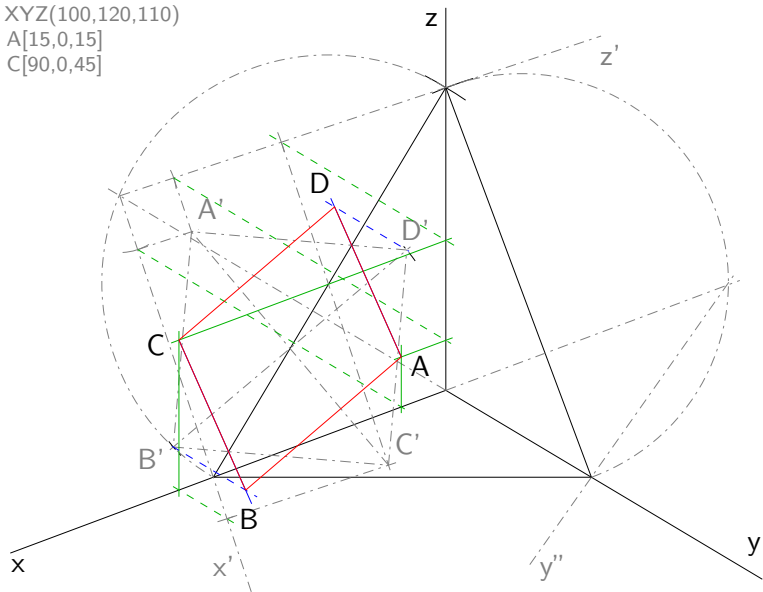

Kolmá axonometrie - krychle

XYZ(100,120,110)

A[15,0,15]

C[90,0,45]

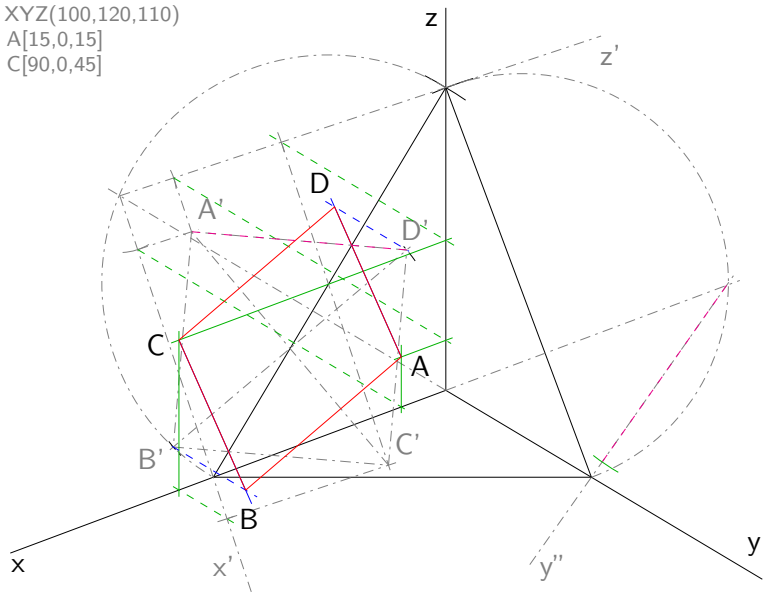

Kolmá axonometrie - krychle

XYZ(100,120,110)

A[15,0,15]

C[90,0,45]

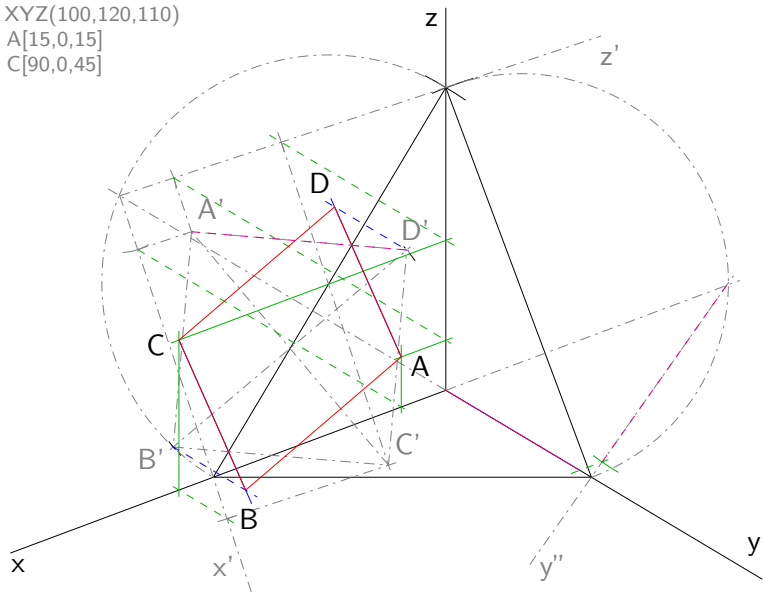

Kolmá axonometrie - krychle

XYZ(100,120,110)

A[15,0,15]

C[90,0,45]

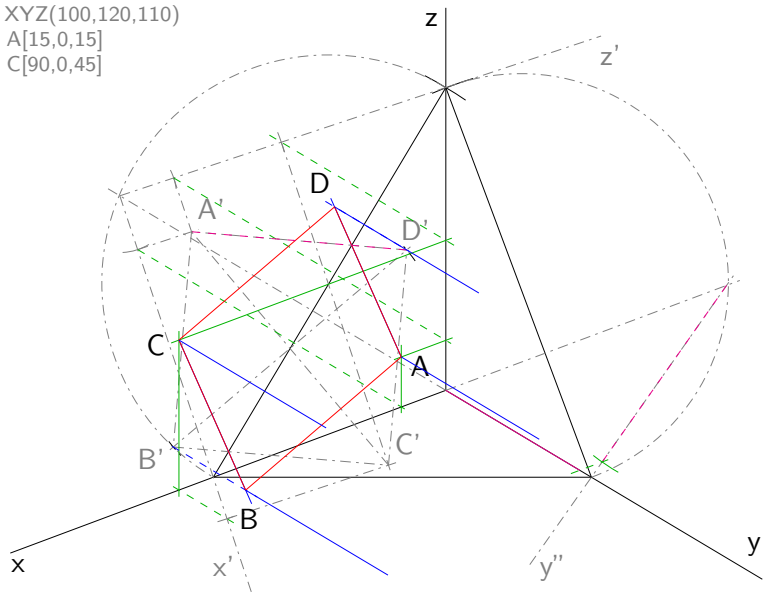

Kolmá axonometrie - krychle

XYZ(100,120,110)

A[15,0,15]

C[90,0,45]

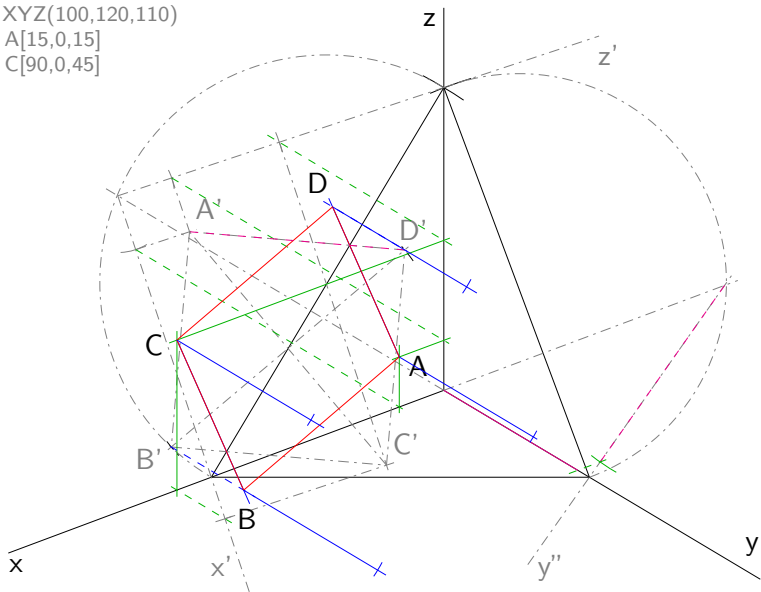

Kolmá axonometrie - krychle

XYZ(100,120,110)

A[15,0,15]

C[90,0,45]

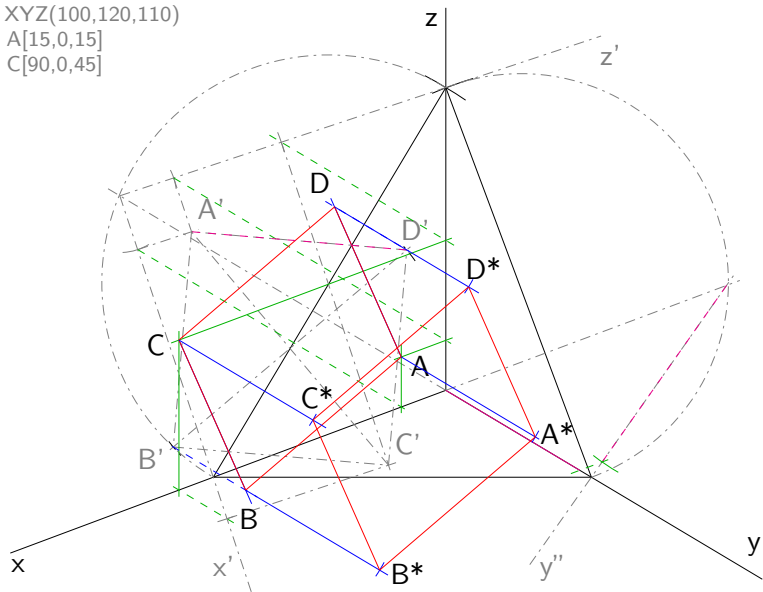

Kolmá axonometrie - krychle

XYZ(100,120,110)

A[15,0,15]

C[90,0,45]

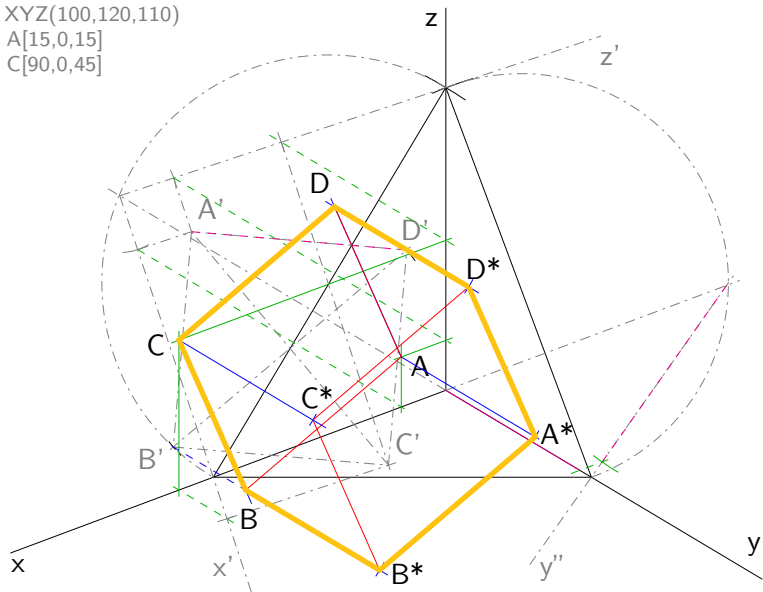

Kolmá axonometrie - krychle

XYZ(100,120,110)

A[15,0,15]

C[90,0,45]

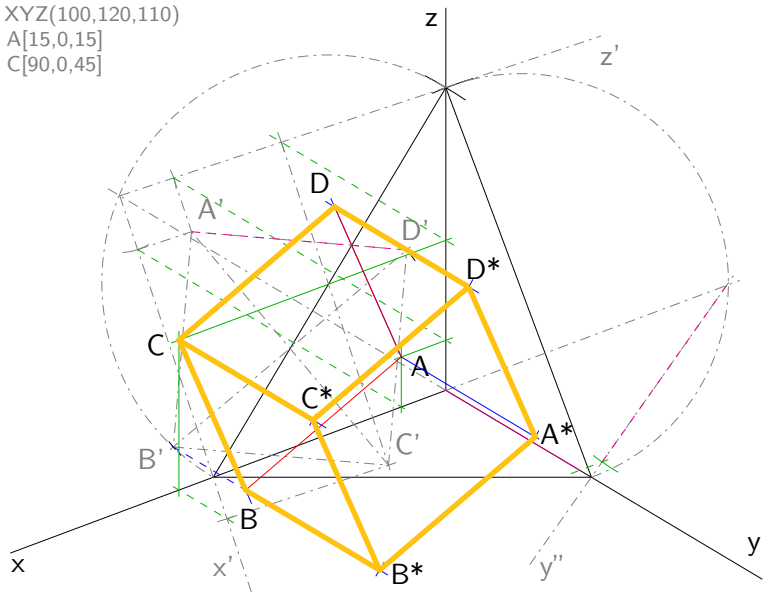

Kolmá axonometrie - krychle

XYZ(100,120,110)

A[15,0,15]

C[90,0,45]

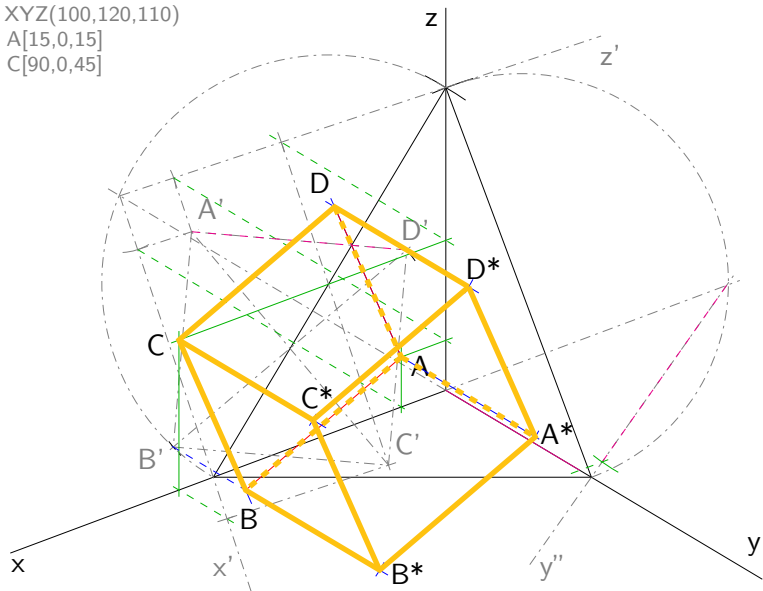

Kolmá axonometrie - hranol

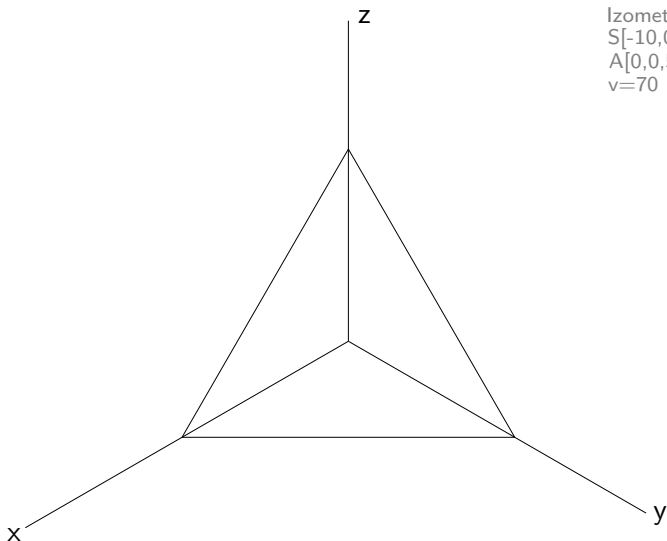

Izometrie
 $S[-10,0,0]$
 $A[0,0,50]$
 $v=70$

Kolmá axonometrie - hranol

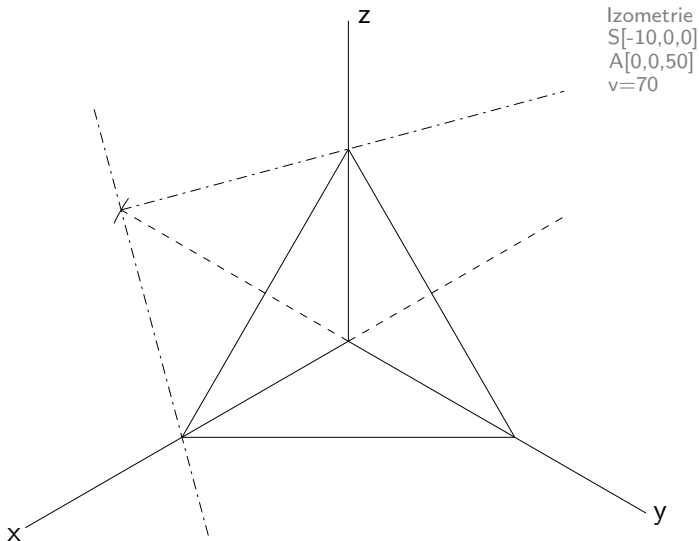

Kolmá axonometrie - hranol

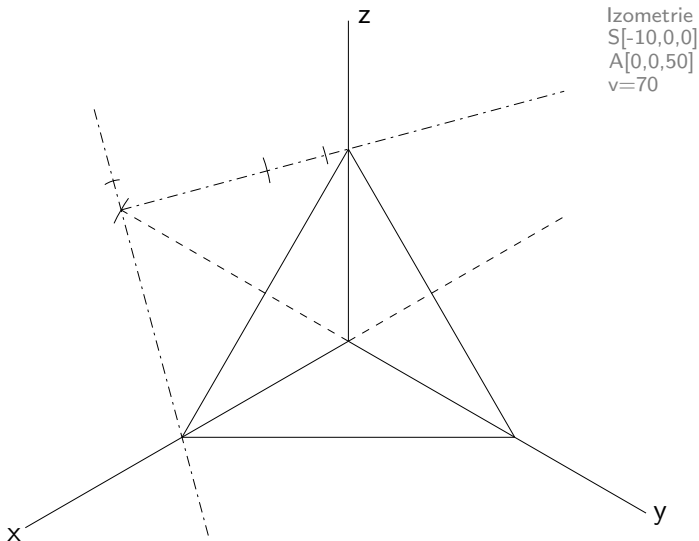

Kolmá axonometrie - hranol

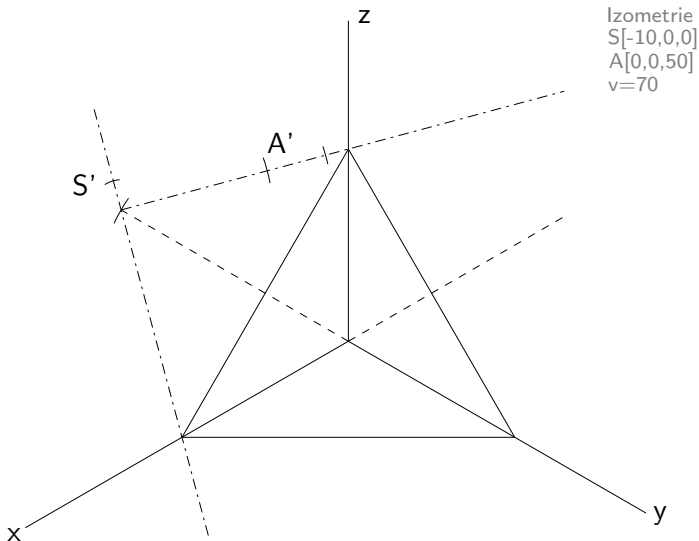

Kolmá axonometrie - hranol

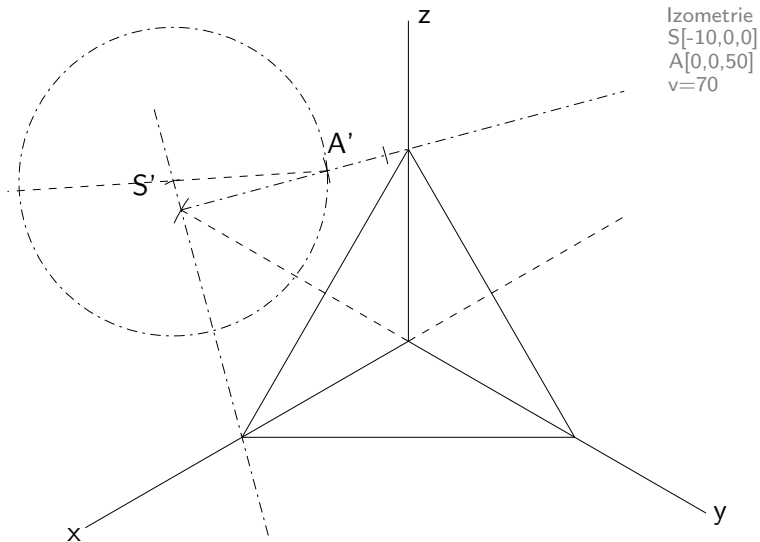

Kolmá axonometrie - hranol

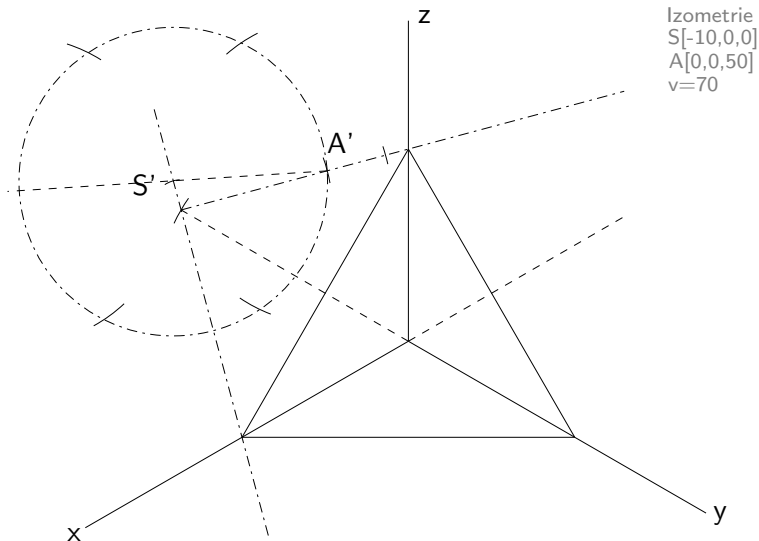

Kolmá axonometrie - hranol

Izometrie
 $S[-10,0,0]$
 $A[0,0,50]$
 $v=70$

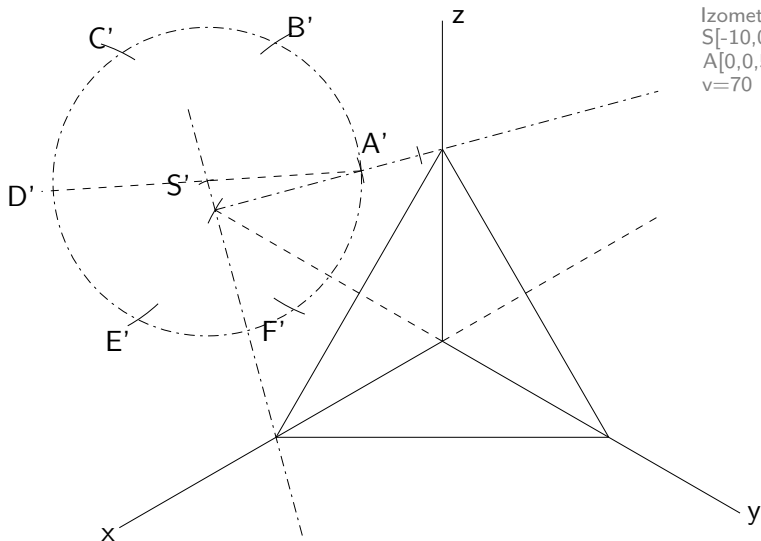

Kolmá axonometrie - hranol

Izometrie
 $S[-10,0,0]$
 $A[0,0,50]$
 $v=70$

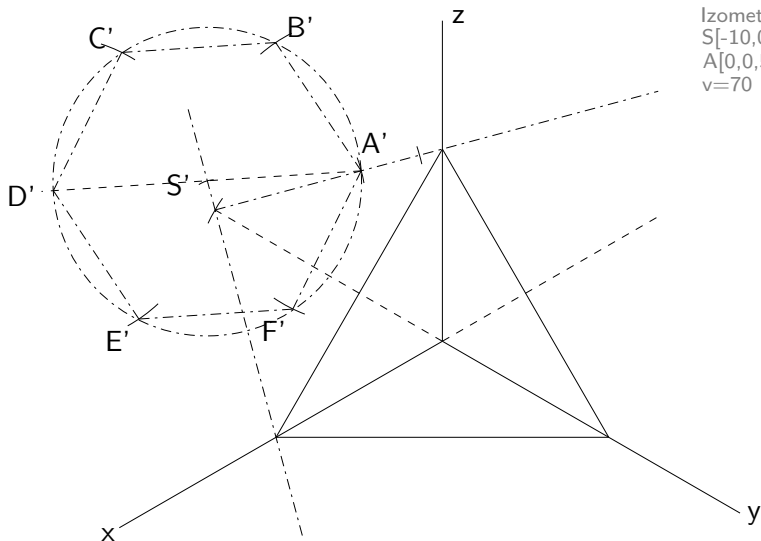

Kolmá axonometrie - hranol

Izometrie
 $S[-10,0,0]$
 $A[0,0,50]$
 $v=70$

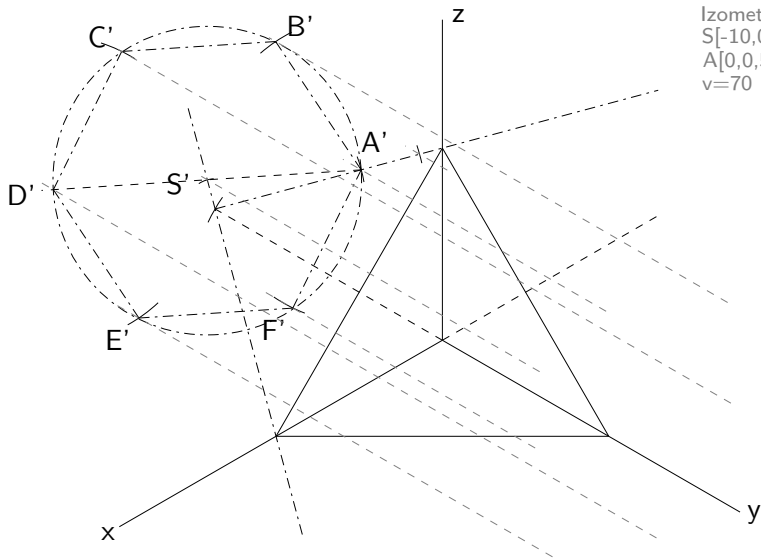

Kolmá axonometrie - hranol

Izometrie
 $S[-10,0,0]$
 $A[0,0,50]$
 $v=70$

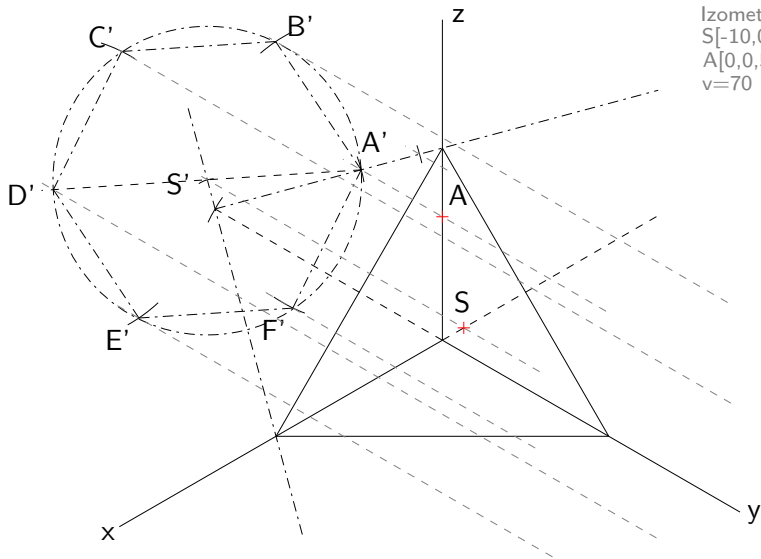

Kolmá axonometrie - hranol

Izometrie
 $S[-10,0,0]$
 $A[0,0,50]$
 $v=70$

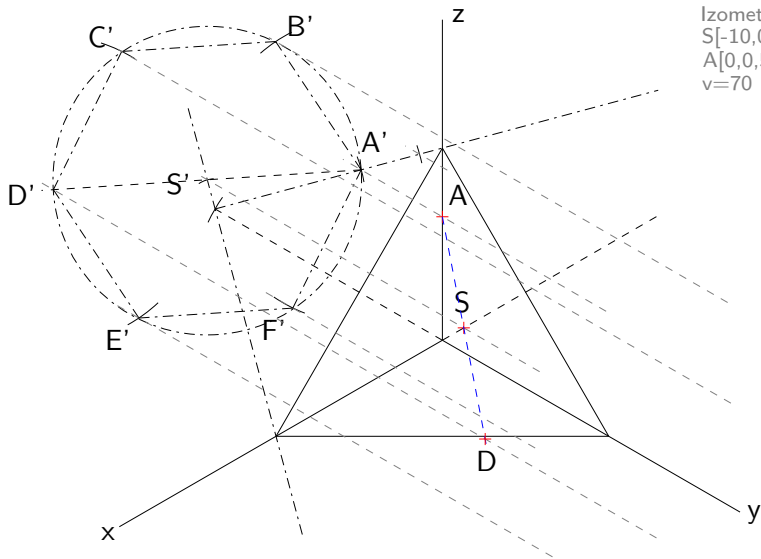

Kolmá axonometrie - hranol

Izometrie
 $S[-10,0,0]$
 $A[0,0,50]$
 $v=70$

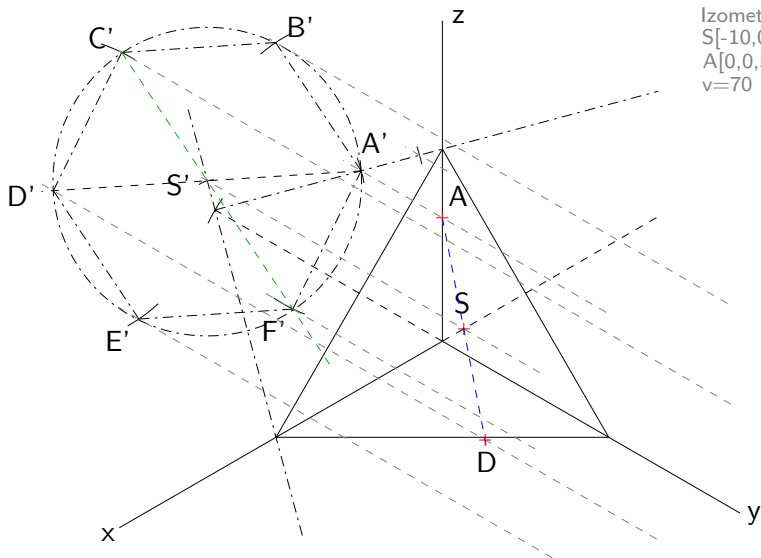

Kolmá axonometrie - hranol

Izometrie
 $S[-10,0,0]$
 $A[0,0,50]$
 $v=70$

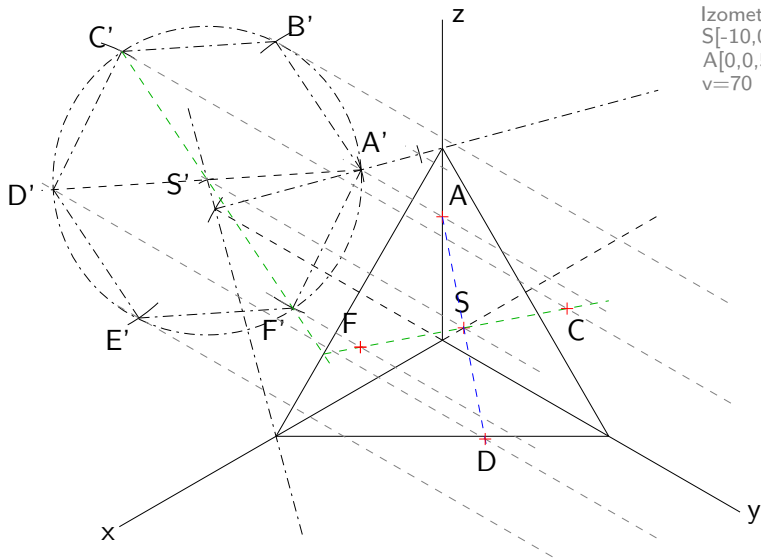

Kolmá axonometrie - hranol

Izometrie
 $S[-10,0,0]$
 $A[0,0,50]$
 $v=70$

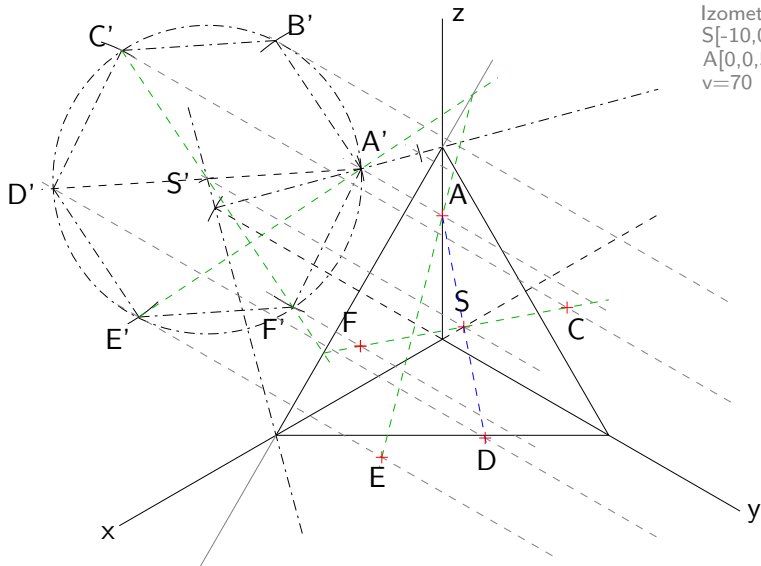

Kolmá axonometrie - hranol

Izometrie
 $S[-10,0,0]$
 $A[0,0,50]$
 $v=70$

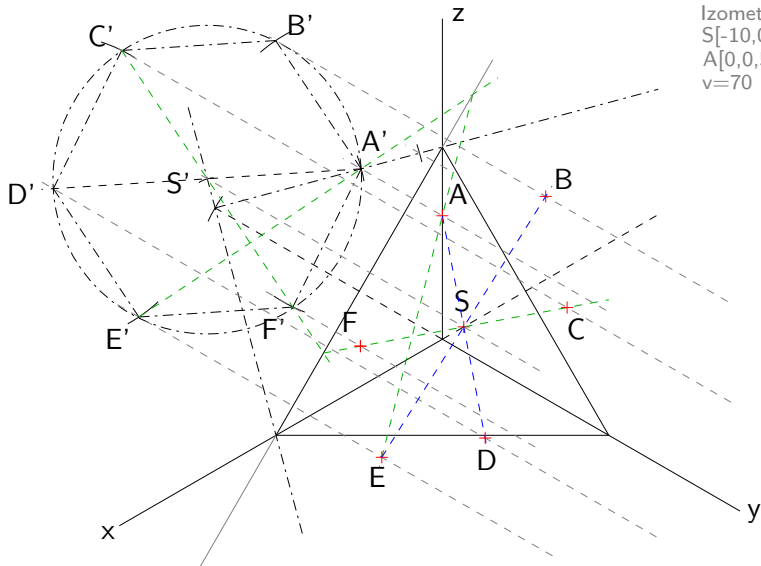

Kolmá axonometrie - hranol

Izometrie
 $S[-10,0,0]$
 $A[0,0,50]$
 $v=70$

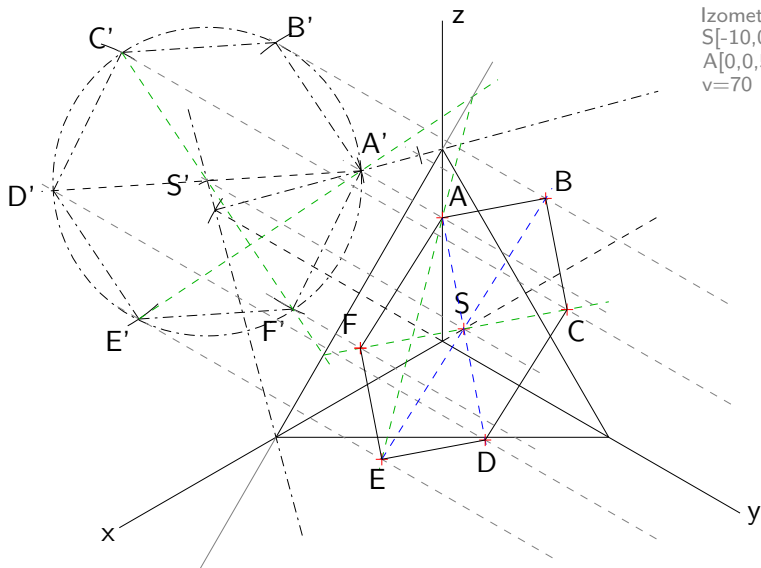

Kolmá axonometrie - hranol

Izometrie
 $S[-10,0,0]$
 $A[0,0,50]$
 $v=70$

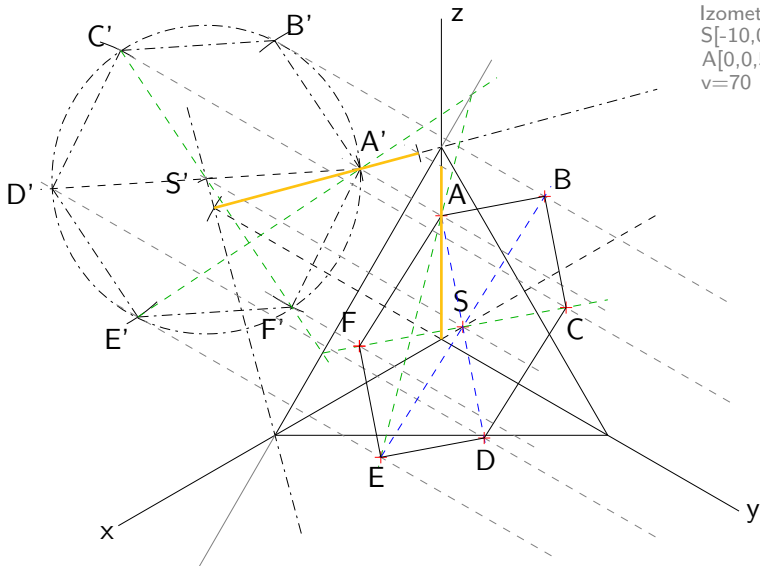

Kolmá axonometrie - hranol

Izometrie
 $S[-10,0,0]$
 $A[0,0,50]$
 $v=70$

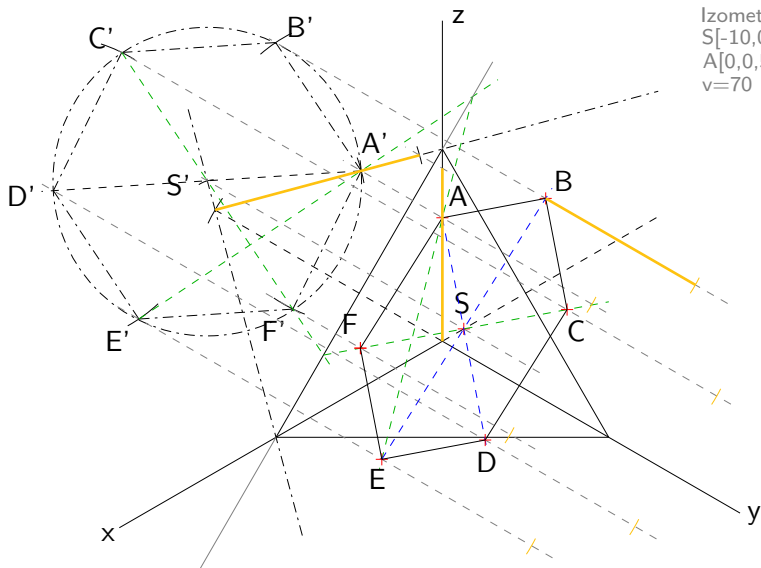

Kolmá axonometrie - hranol

Izometrie
 $S[-10,0,0]$
 $A[0,0,50]$
 $v=70$

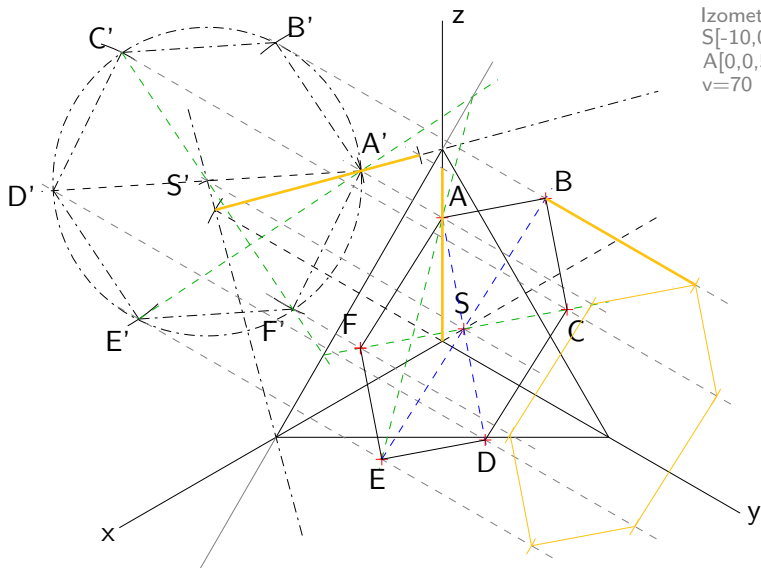

Kolmá axonometrie - hranol

Izometrie
 $S[-10,0,0]$
 $A[0,0,50]$
 $v=70$

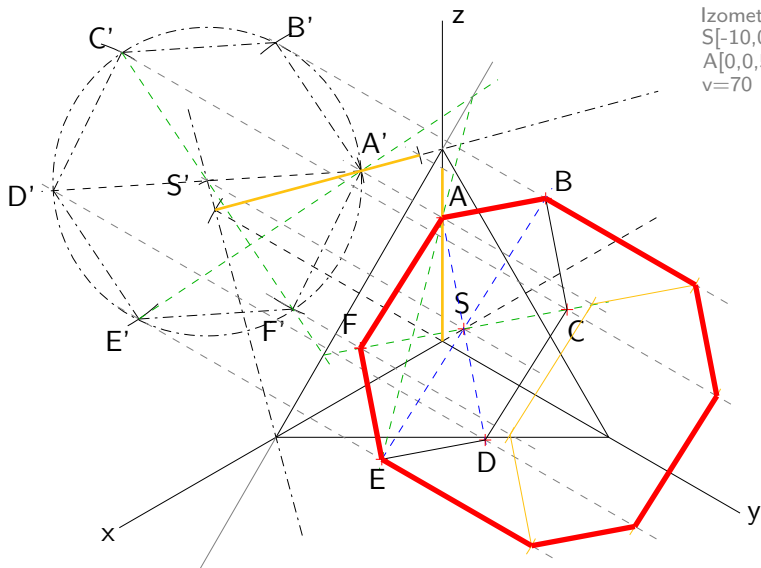

Kolmá axonometrie - hranol

Izometrie
 $S[-10,0,0]$
 $A[0,0,50]$
 $v=70$

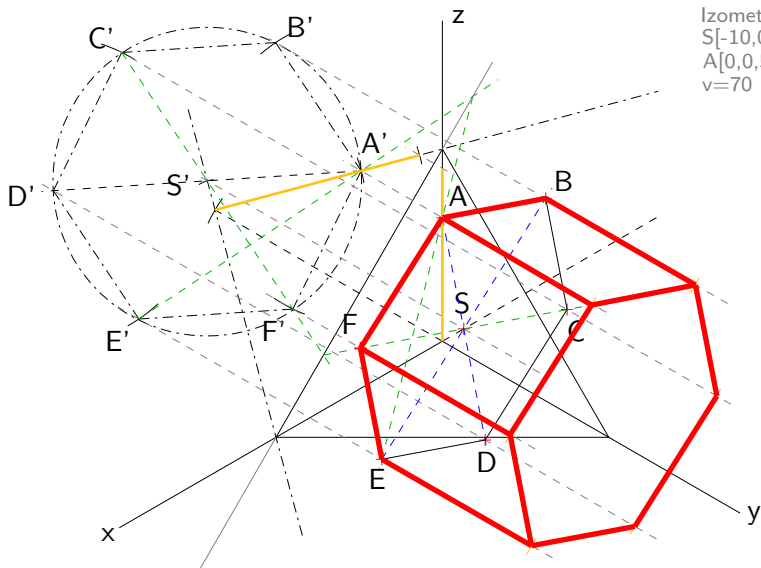

Kolmá axonometrie - hranol

Izometrie
 $S[-10,0,0]$
 $A[0,0,50]$
 $v=70$

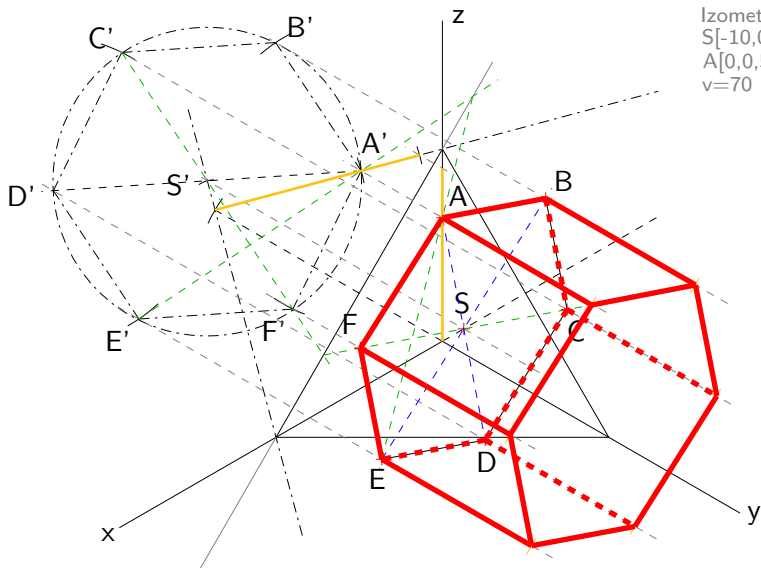

Kolmá axonometrie - kužel

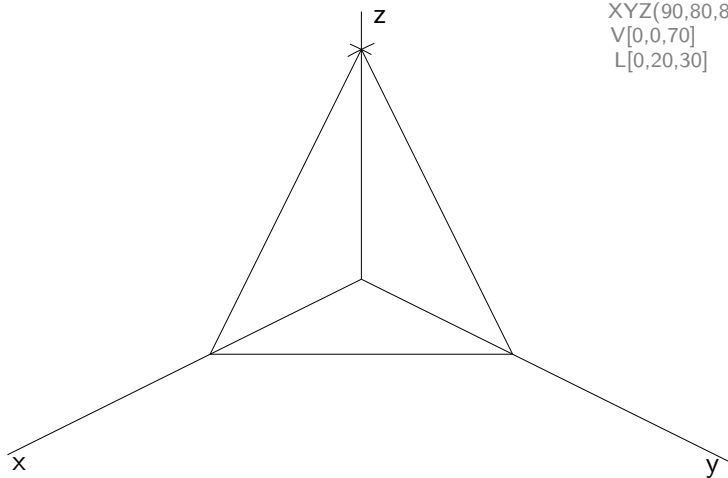

$XYZ(90,80,80)$

$V[0,0,70]$

$L[0,20,30]$

Kolmá axonometrie - kužel

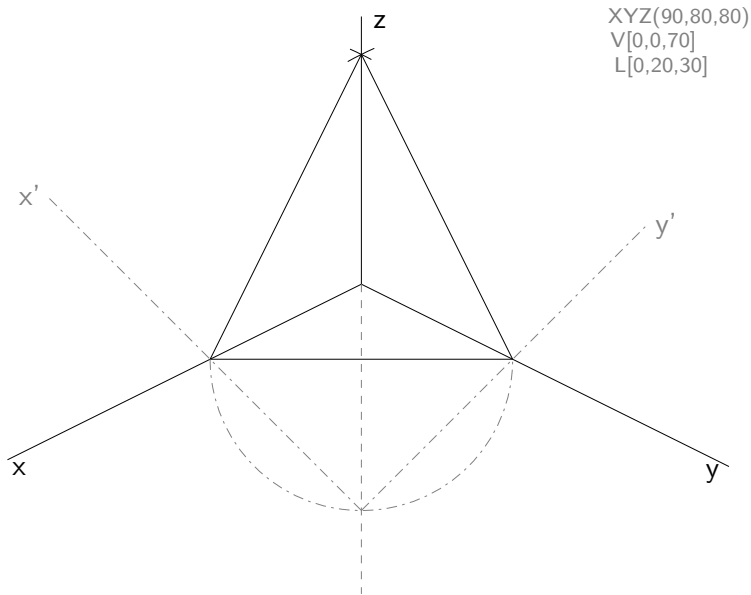

Kolmá axonometrie - kužel

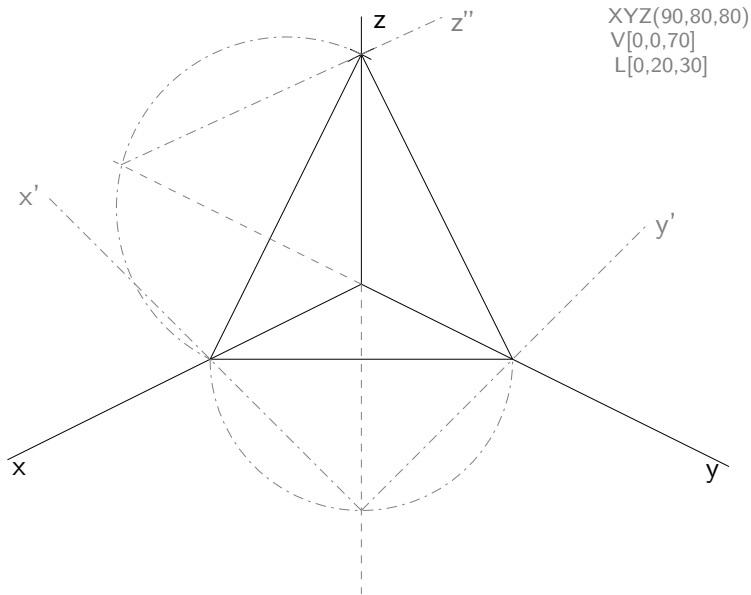

Kolmá axonometrie - kužel

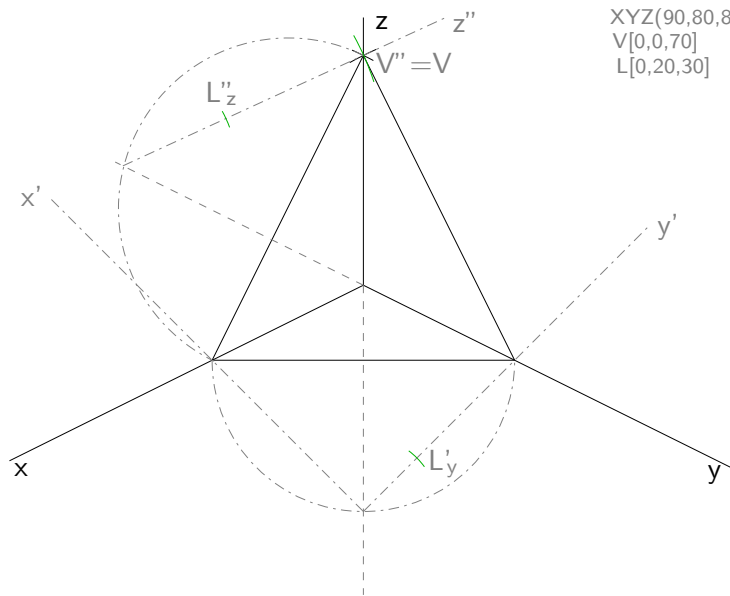

Kolmá axonometrie - kužel

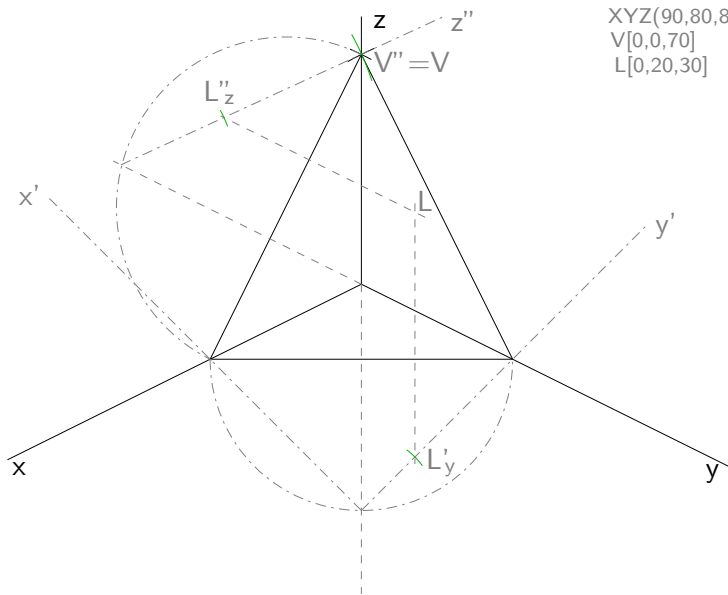

Kolmá axonometrie - kužel

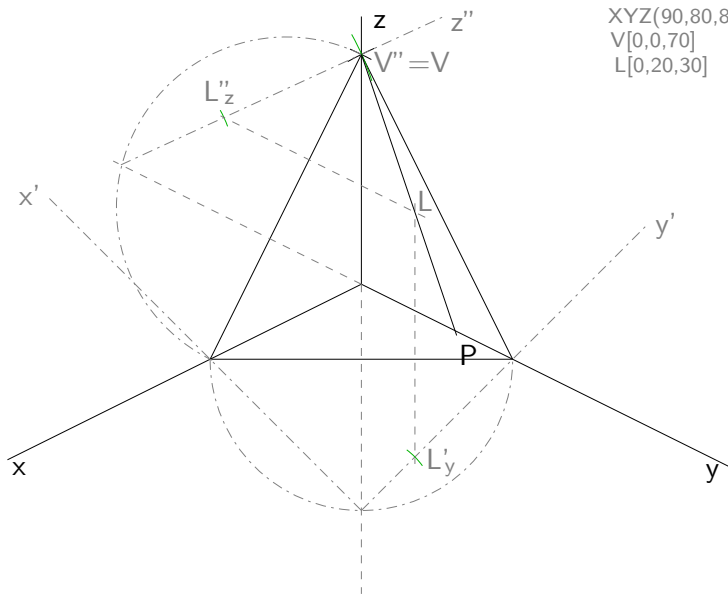

Kolmá axonometrie - kužel

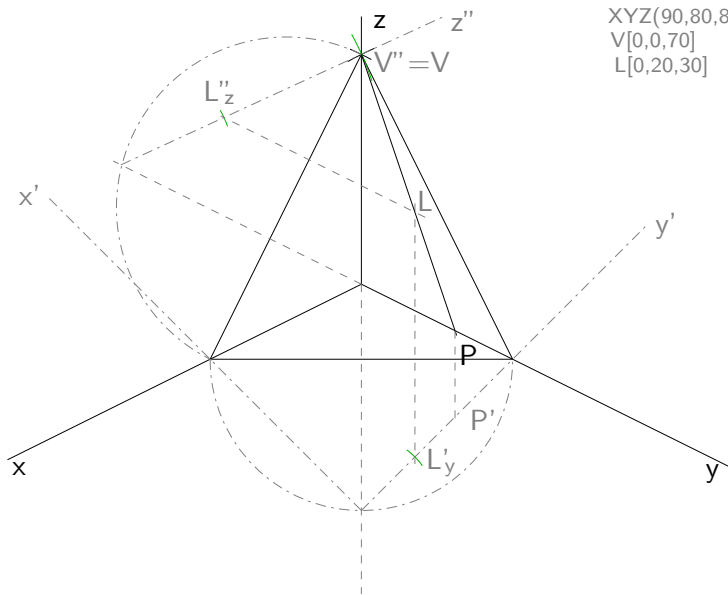

$XYZ(90,80,80)$

$V[0,0,70]$

$L[0,20,30]$

Kolmá axonometrie - kužel

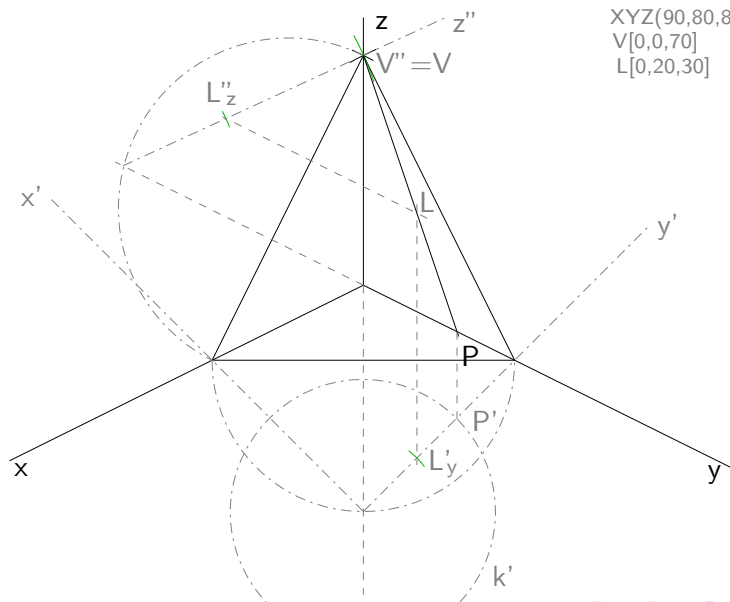

Kolmá axonometrie - kužel

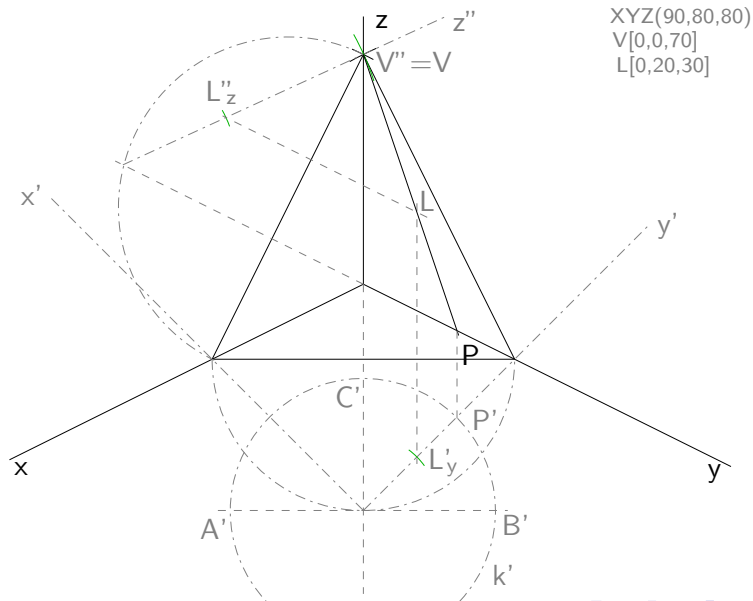

Kolmá axonometrie - kužel

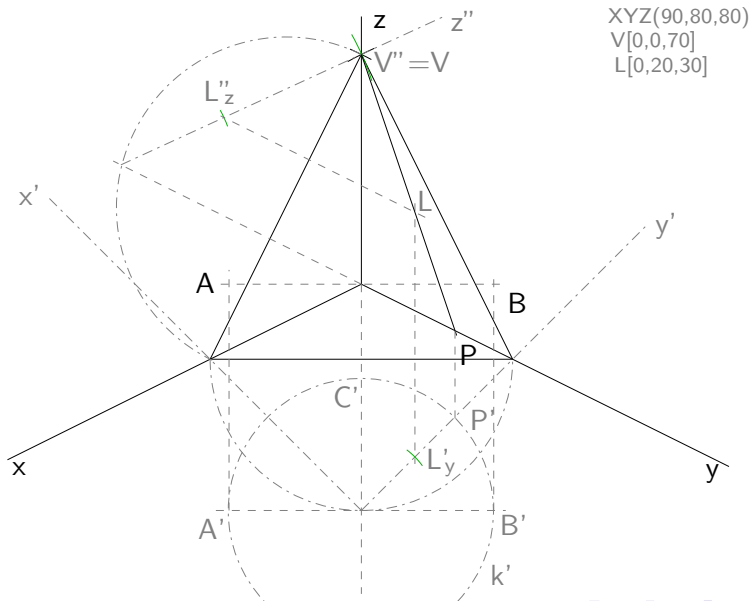

Kolmá axonometrie - kužel

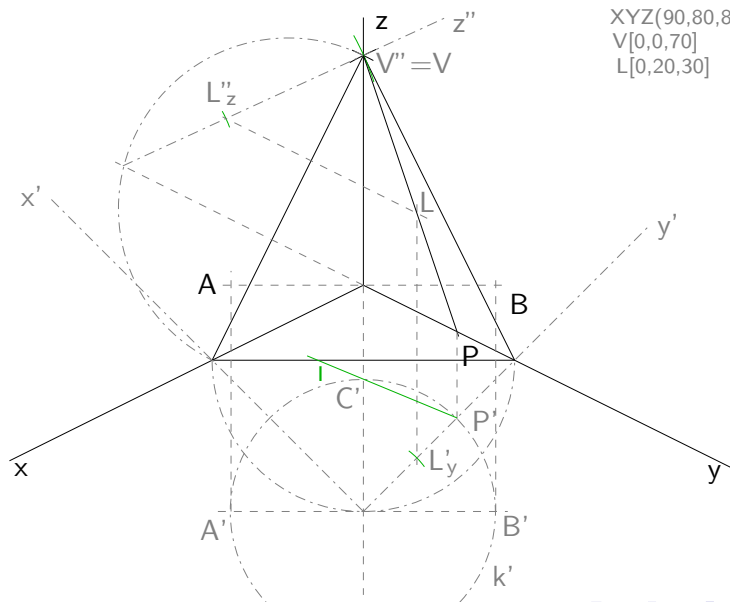

Kolmá axonometrie - kužel

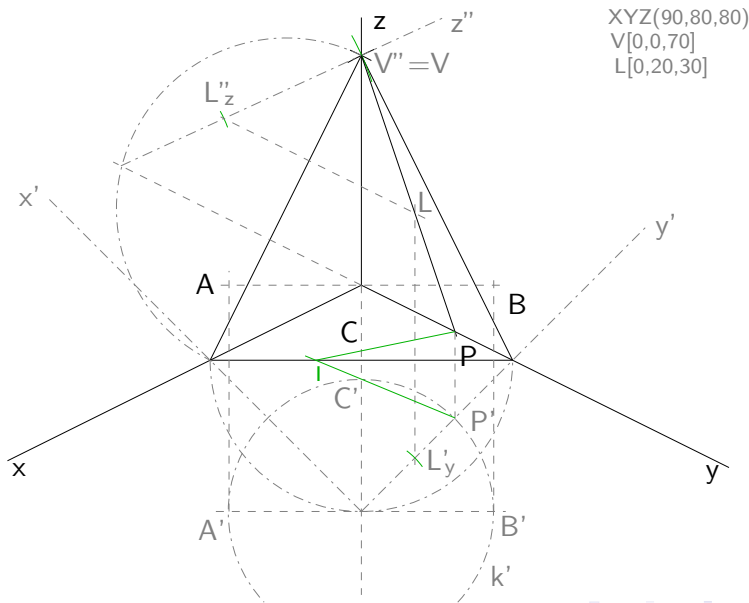

Kolmá axonometrie - kužel

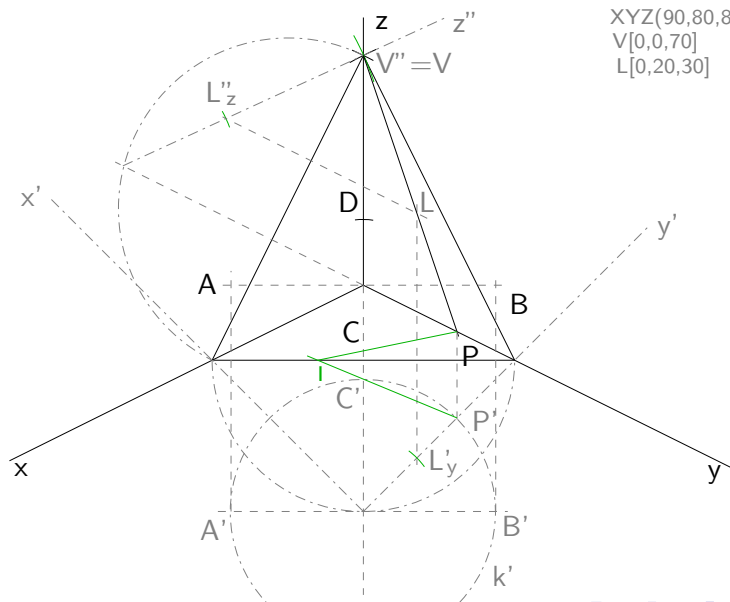

Kolmá axonometrie - kužel

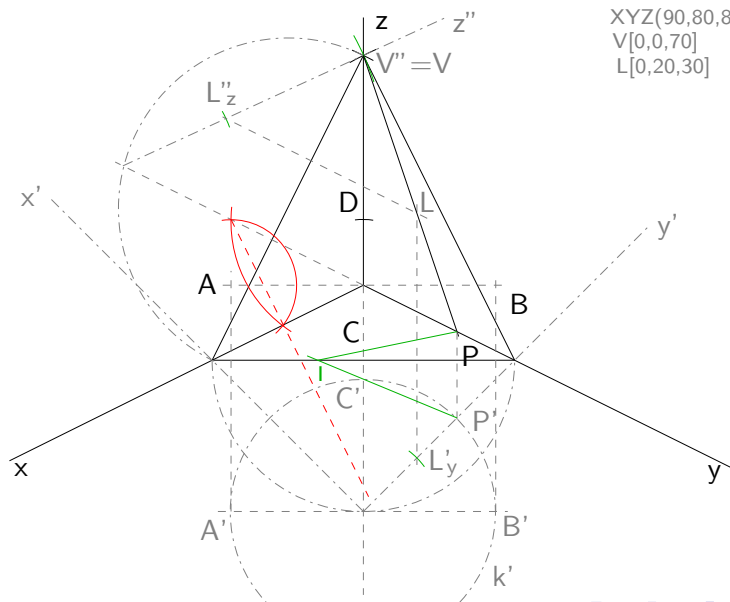

Kolmá axonometrie - kužel

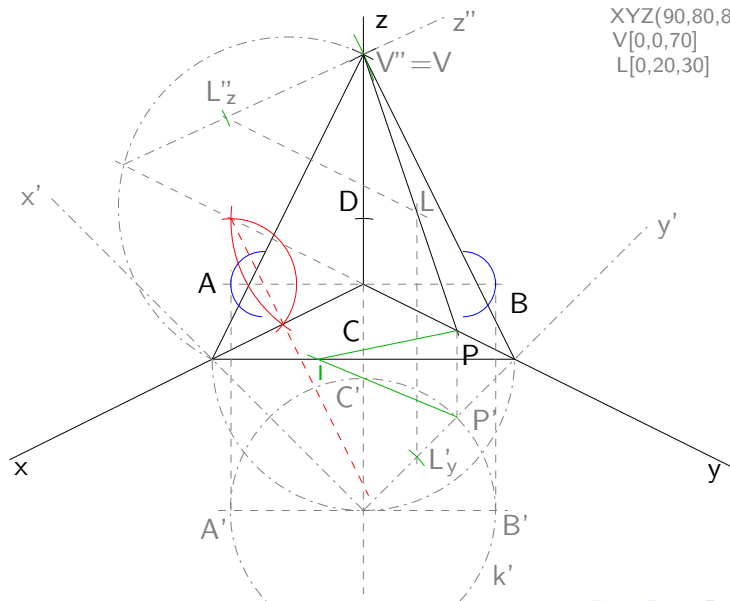

$XYZ(90,80,80)$
 $V[0,0,70]$
 $L[0,20,30]$

Kolmá axonometrie - kužel

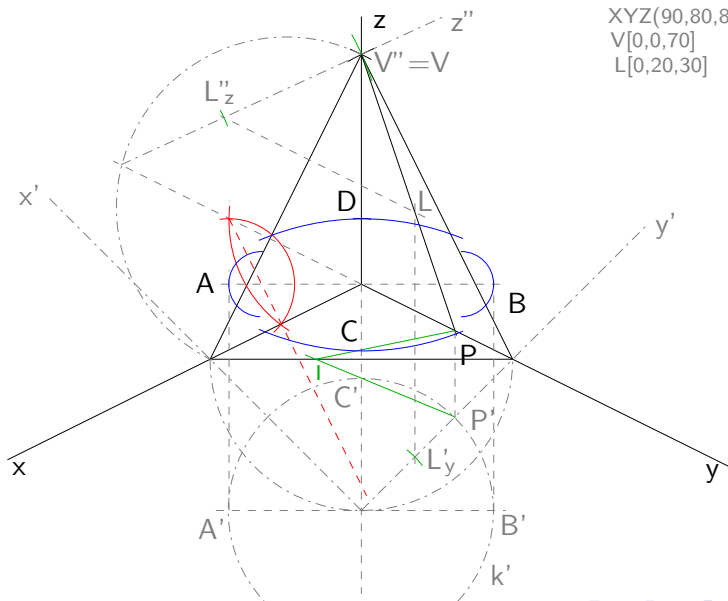

Kolmá axonometrie - kužel

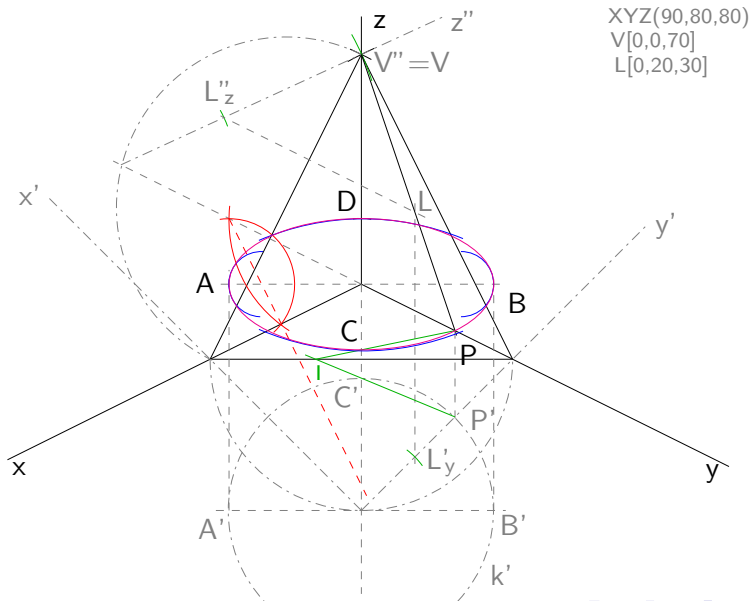

Kolmá axonometrie - kužel

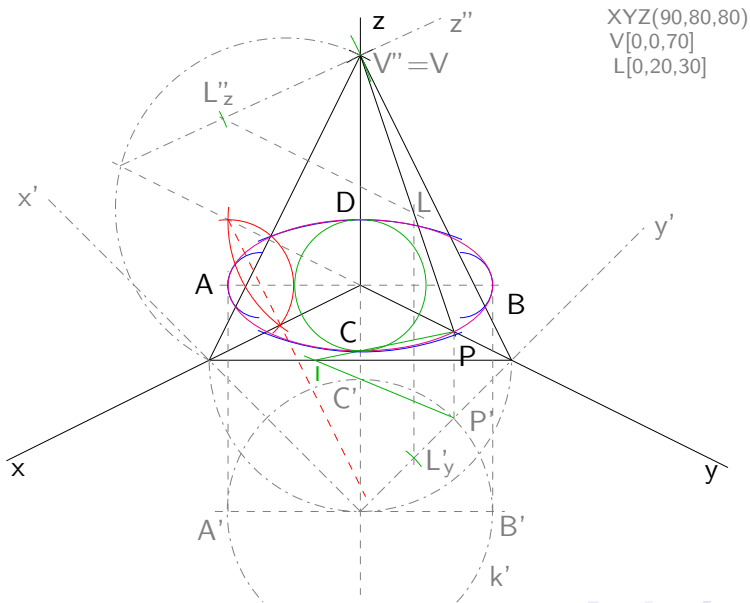

Kolmá axonometrie - kužel

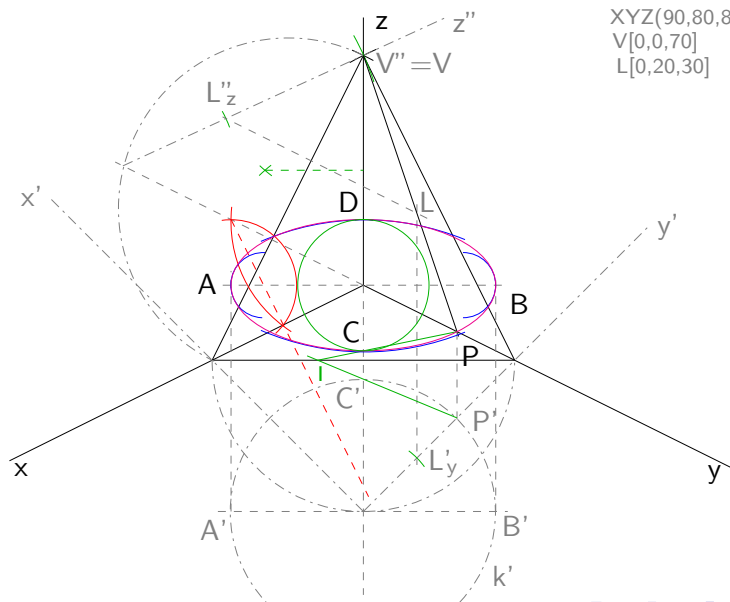

Kolmá axonometrie - kužel

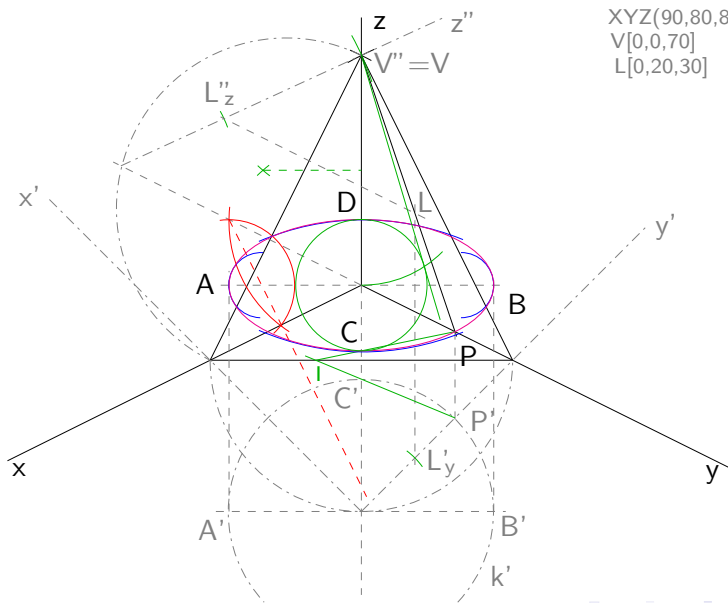

Kolmá axonometrie - kužel

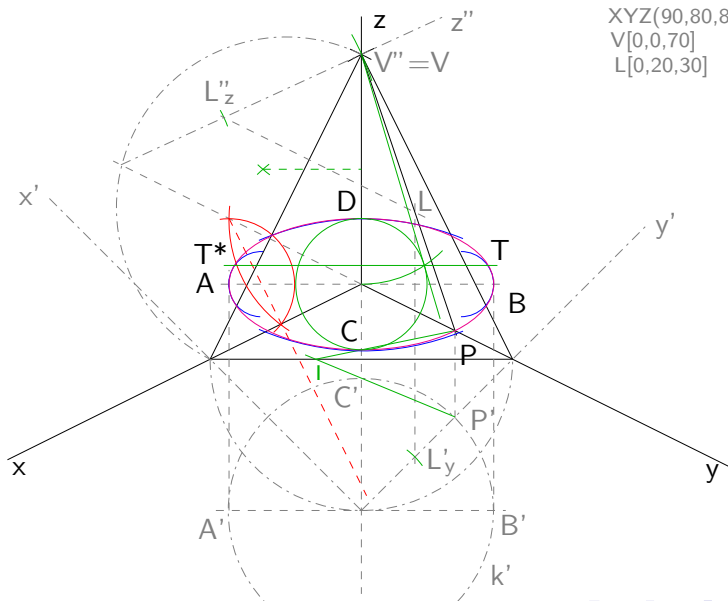

Kolmá axonometrie - kužel

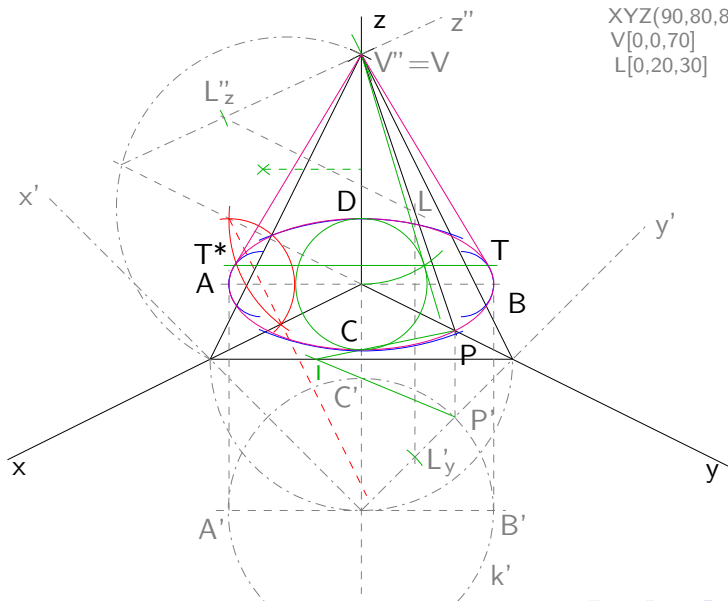

Kolmá axonometrie - kužel

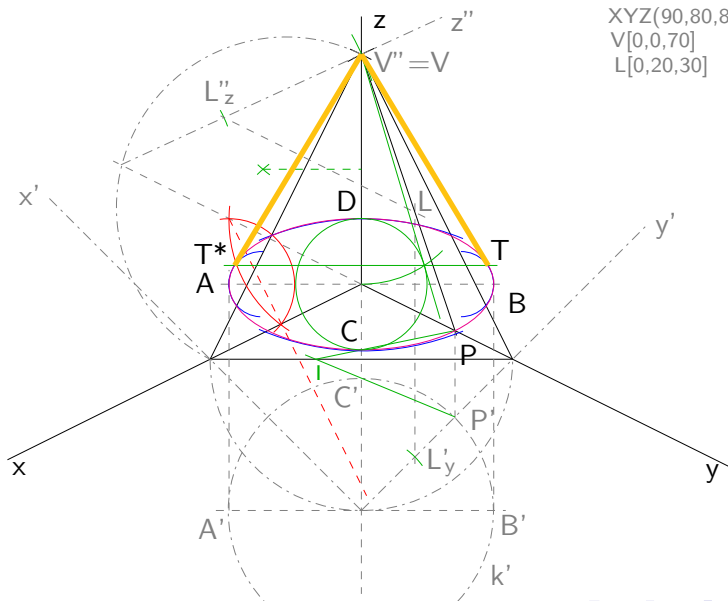

Kolmá axonometrie - kužel

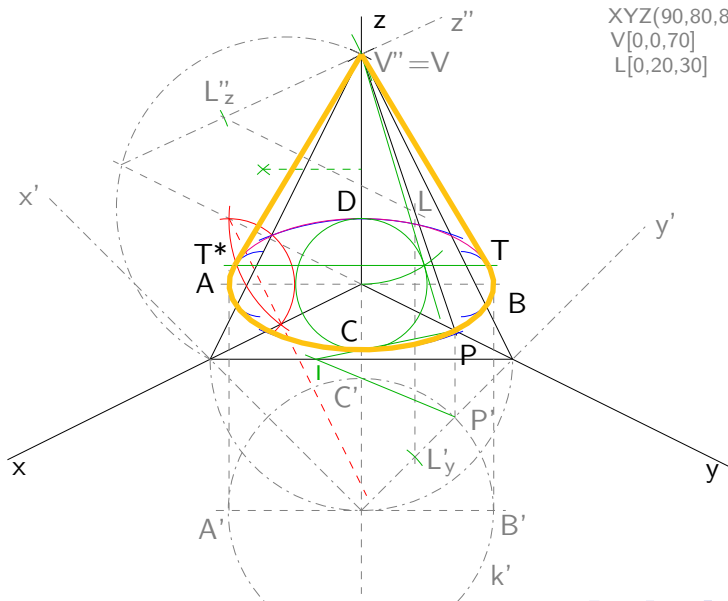

$XYZ(90,80,80)$
 $V[0,0,70]$
 $L[0,20,30]$

Kolmá axonometrie - kužel

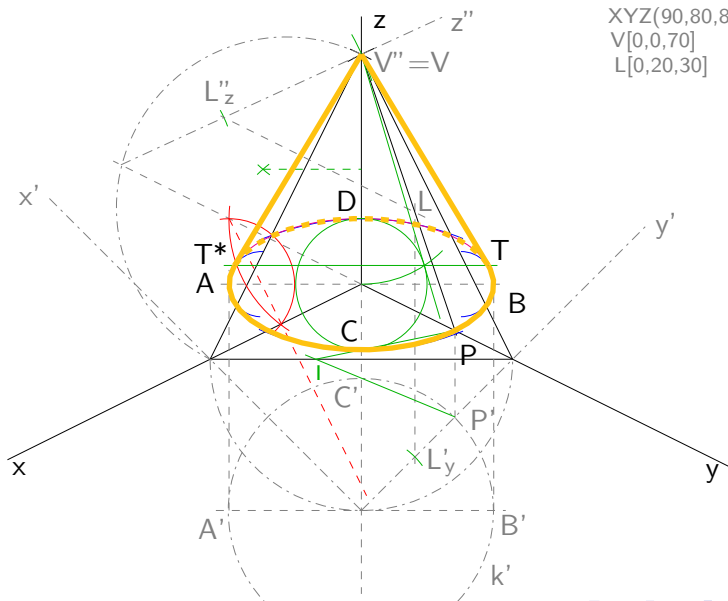

$XYZ(90,80,80)$
 $V[0,0,70]$
 $L[0,20,30]$

Kolmá axonometrie - řez hranolu

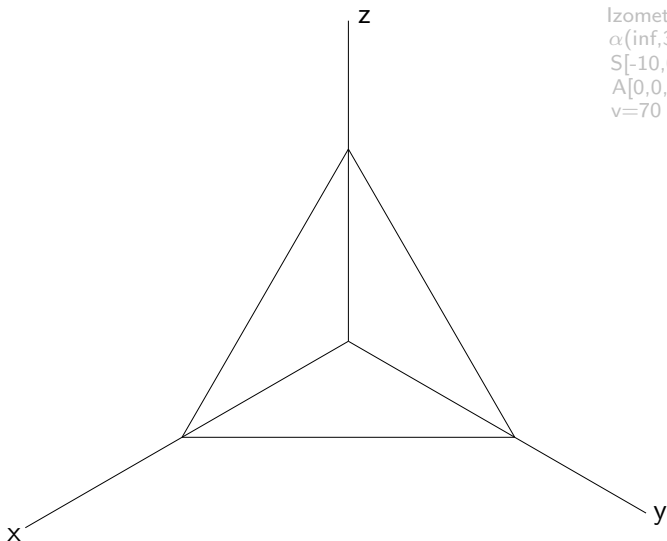

Izometrie
 $\alpha(\text{inf}, 30, 70)$
 $S[-10, 0, 0]$
 $A[0, 0, 50]$
 $v=70$

Kolmá axonometrie - řez hranolu

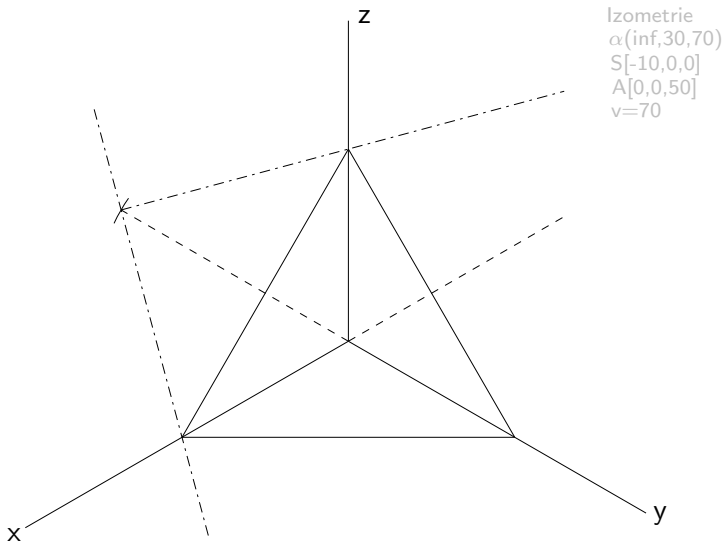

Kolmá axonometrie - řez hranolu

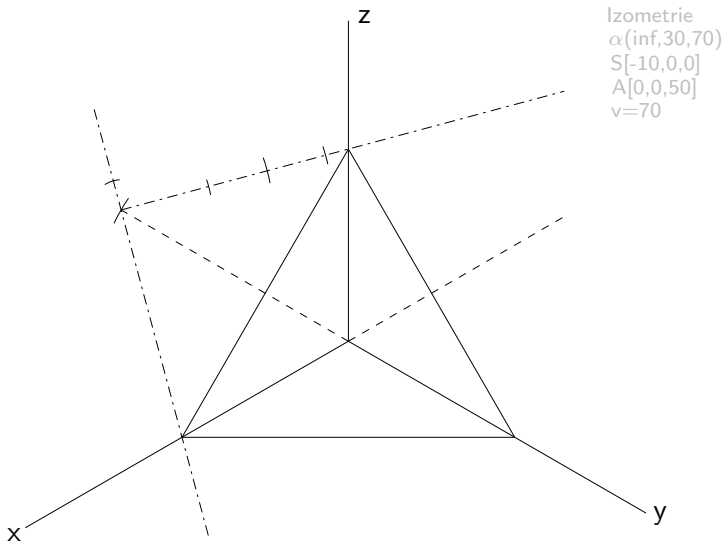

Kolmá axonometrie - řez hranolu

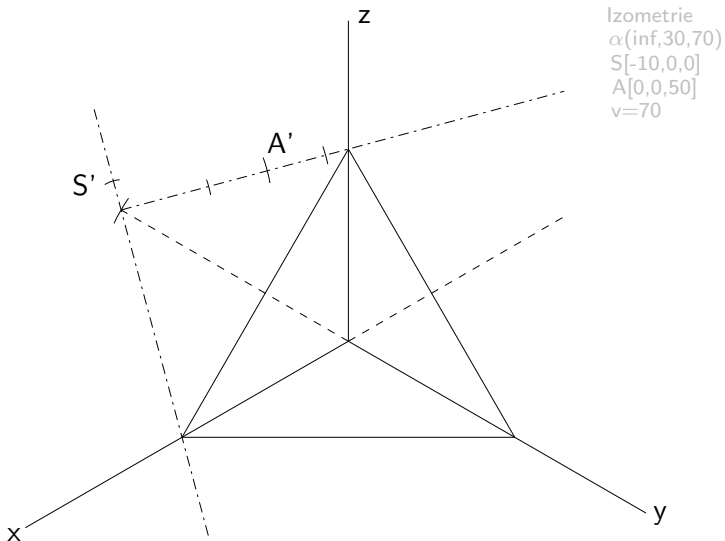

Kolmá axonometrie - řez hranolu

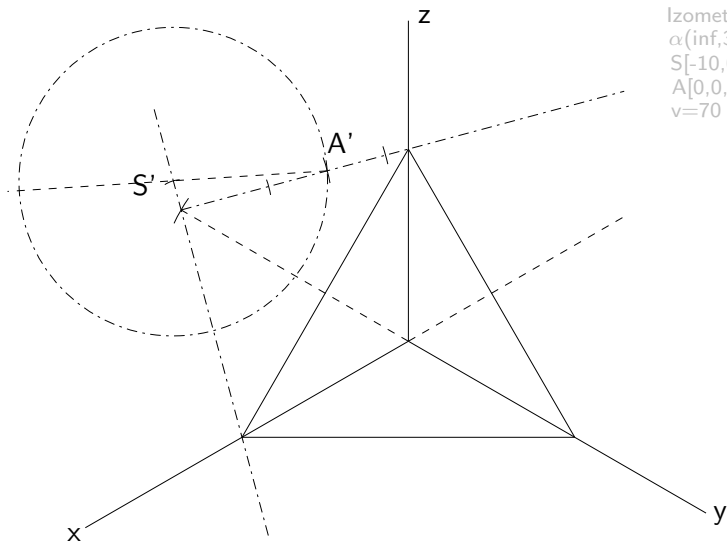

Izometrie
 $\alpha(\text{inf}, 30, 70)$
 $S[-10, 0, 0]$
 $A[0, 0, 50]$
 $v=70$

Kolmá axonometrie - řez hranolu

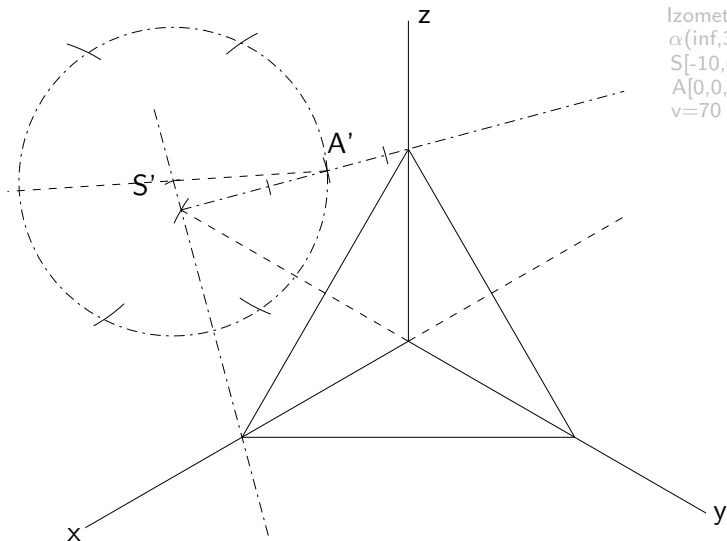

Izometrie
 $\alpha(\text{inf}, 30, 70)$
 $S[-10, 0, 0]$
 $A[0, 0, 50]$
 $v=70$

Kolmá axonometrie - řez hranolu

Izometrie
 $\alpha(\text{inf}, 30, 70)$
 $S[-10, 0, 0]$
 $A[0, 0, 50]$
 $v=70$

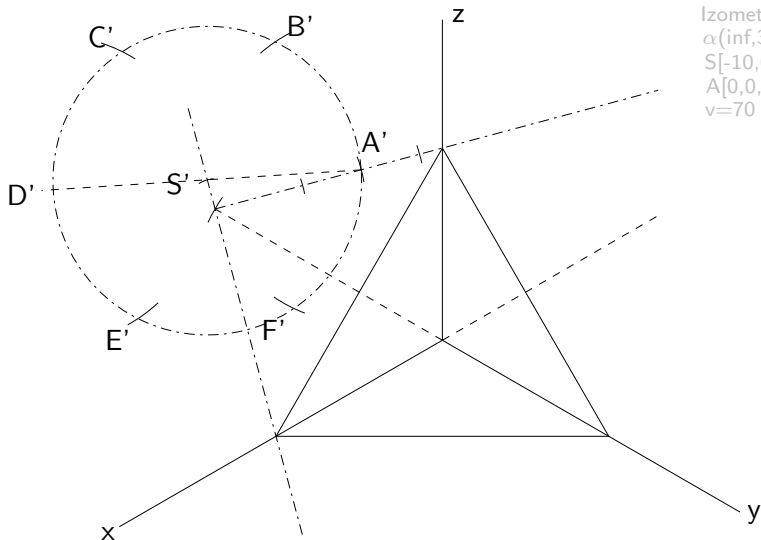

Kolmá axonometrie - řez hranolu

Izometrie
 $\alpha(\text{inf}, 30, 70)$
 $S[-10, 0, 0]$
 $A[0, 0, 50]$
 $v=70$

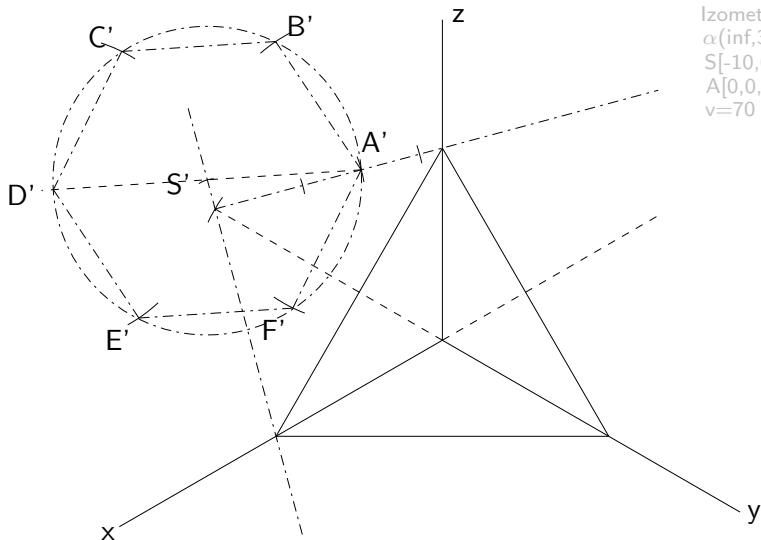

Kolmá axonometrie - řez hranolu

Izometrie
 $\alpha(\text{inf}, 30, 70)$
 $S[-10, 0, 0]$
 $A[0, 0, 50]$
 $v=70$

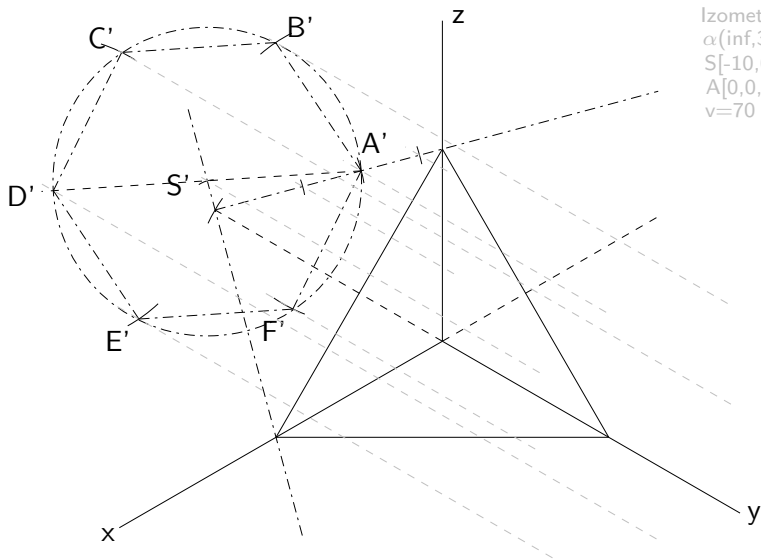

Kolmá axonometrie - řez hranolu

Izometrie
 $\alpha(\text{inf}, 30, 70)$
 $S[-10, 0, 0]$
 $A[0, 0, 50]$
 $v=70$

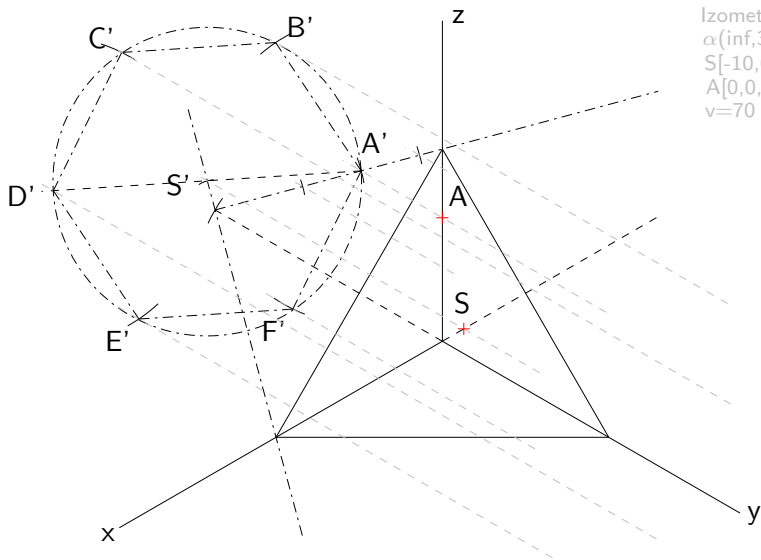

Kolmá axonometrie - řez hranolu

Izometrie
 $\alpha(\text{inf}, 30, 70)$
 $S[-10, 0, 0]$
 $A[0, 0, 50]$
 $v=70$

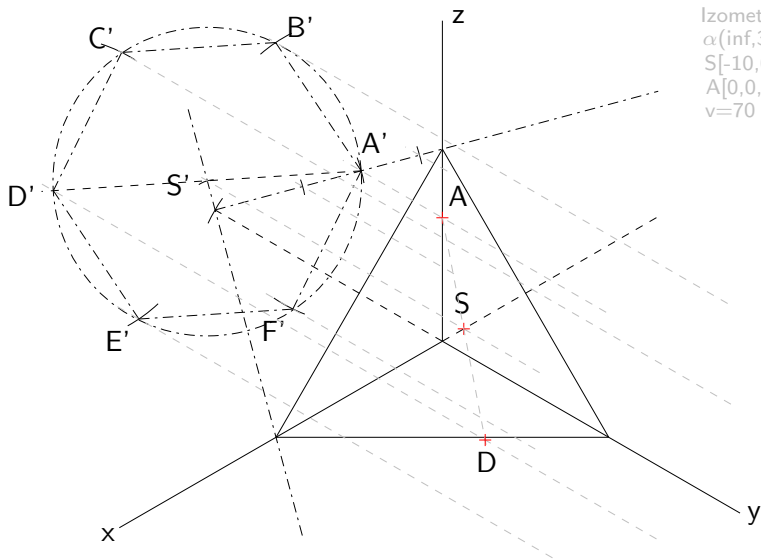

Kolmá axonometrie - řez hranolu

Izometrie
 $\alpha(\text{inf}, 30, 70)$
 $S[-10, 0, 0]$
 $A[0, 0, 50]$
 $v=70$

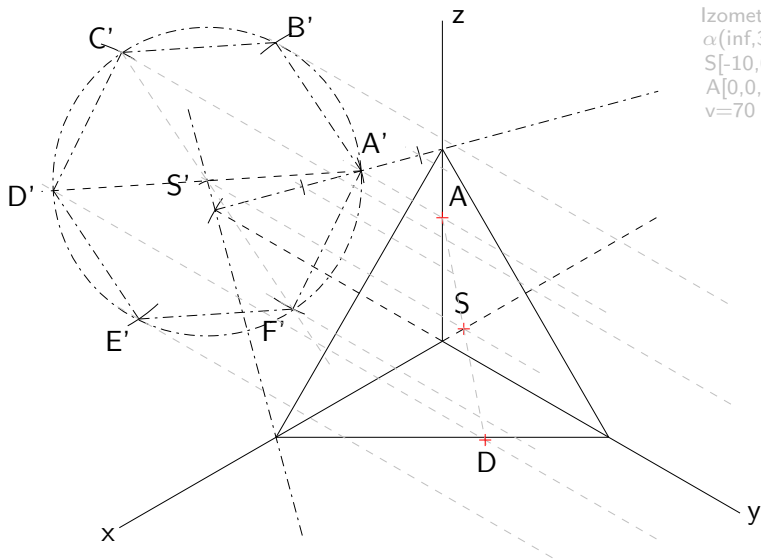

Kolmá axonometrie - řez hranolu

Izometrie
 $\alpha(\text{inf}, 30, 70)$
 $S[-10, 0, 0]$
 $A[0, 0, 50]$
 $v=70$

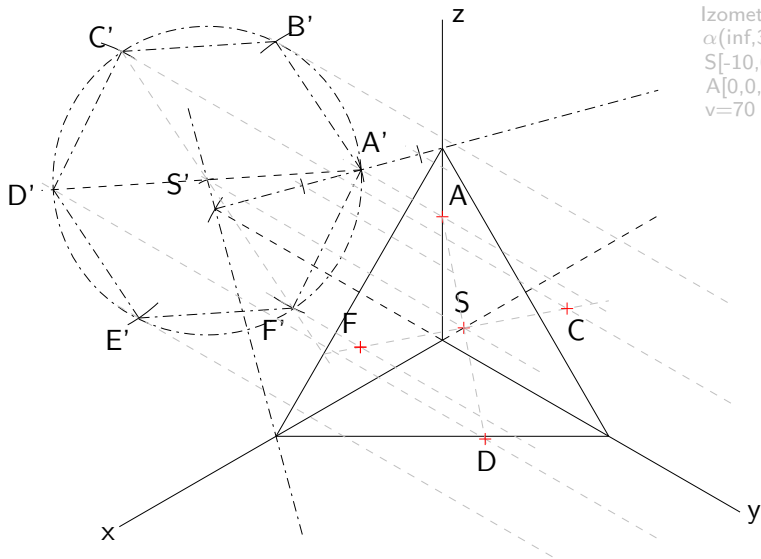

Kolmá axonometrie - řez hranolu

Izometrie
 $\alpha(\text{inf}, 30, 70)$
 $S[-10, 0, 0]$
 $A[0, 0, 50]$
 $v=70$

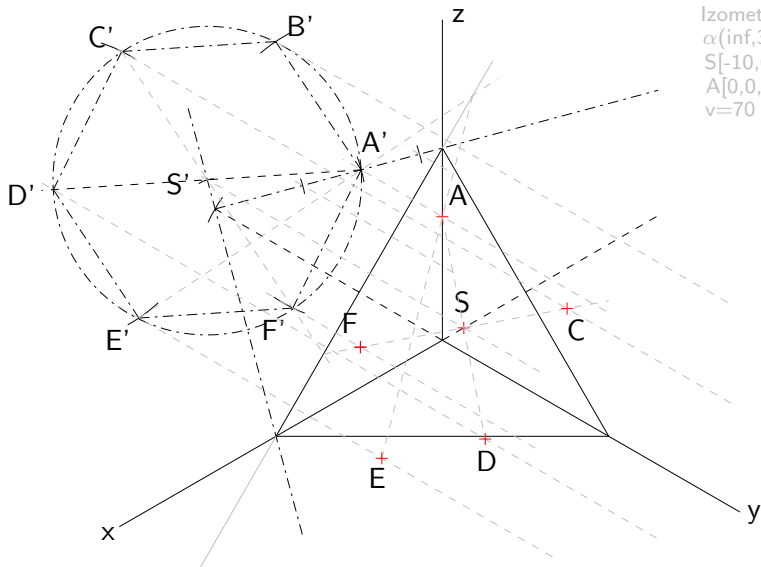

Kolmá axonometrie - řez hranolu

Izometrie
 $\alpha(\text{inf}, 30, 70)$
 $S[-10, 0, 0]$
 $A[0, 0, 50]$
 $v=70$

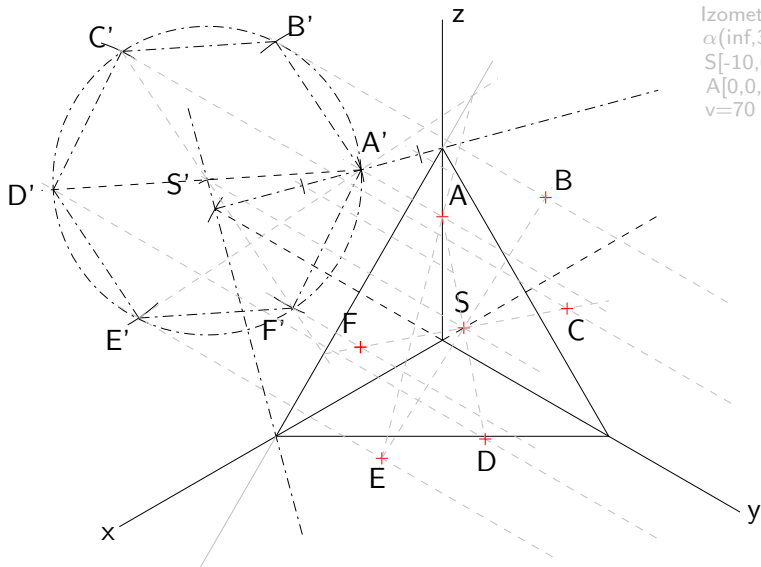

Kolmá axonometrie - řez hranolu

Izometrie
 $\alpha(\text{inf}, 30, 70)$
 $S[-10, 0, 0]$
 $A[0, 0, 50]$
 $v=70$

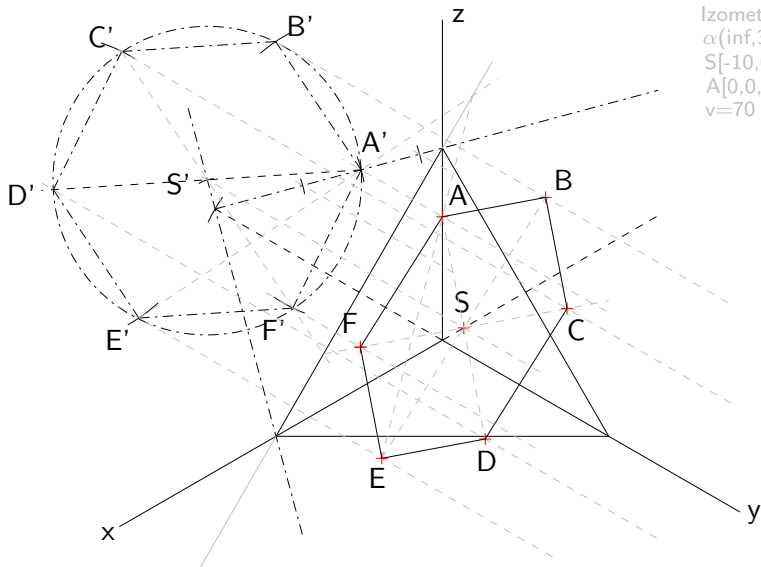

Kolmá axonometrie - řez hranolu

Izometrie
 $\alpha(\text{inf}, 30, 70)$
 $S[-10, 0, 0]$
 $A[0, 0, 50]$
 $v=70$

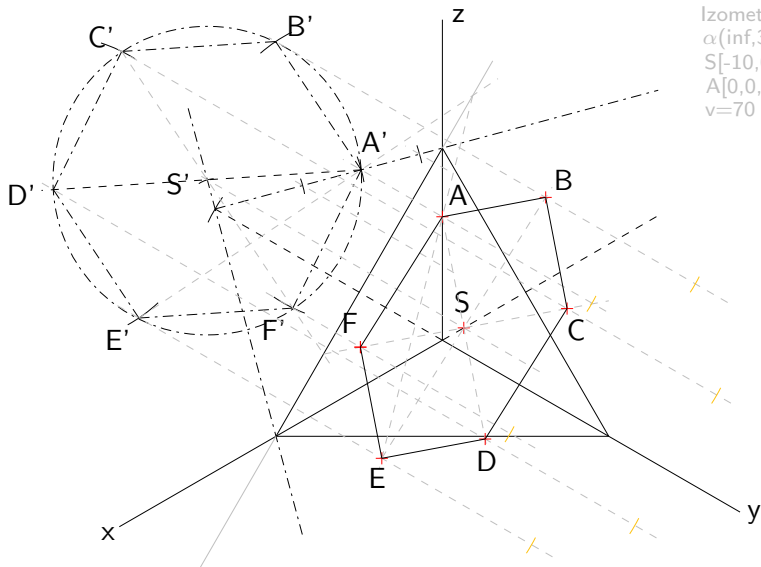

Kolmá axonometrie - řez hranolu

Izometrie
 $\alpha(\text{inf}, 30, 70)$
 $S[-10, 0, 0]$
 $A[0, 0, 50]$
 $v=70$

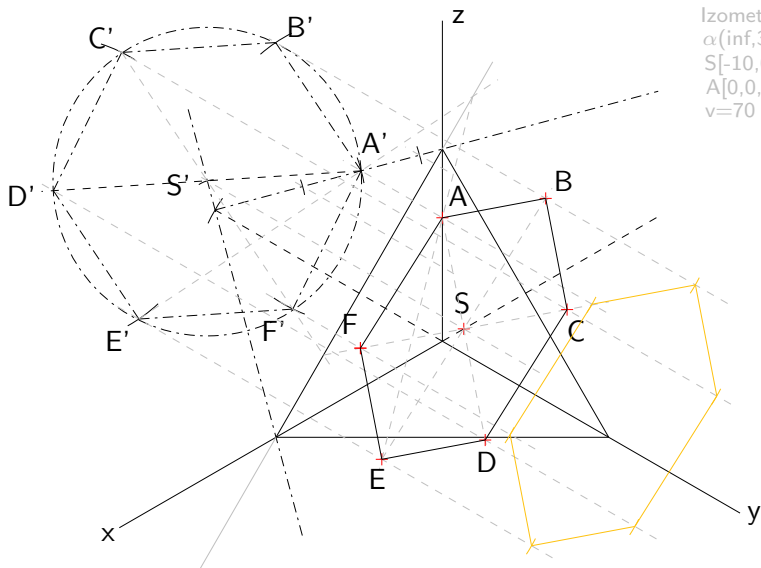

Kolmá axonometrie - řez hranolu

Izometrie
 $\alpha(\text{inf}, 30, 70)$
 $S[-10, 0, 0]$
 $A[0, 0, 50]$
 $v=70$

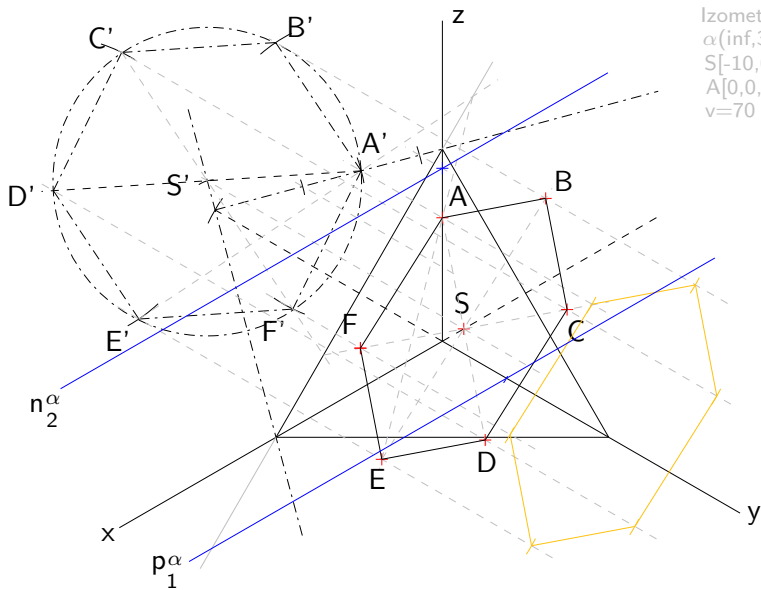

Kolmá axonometrie - řez hranolu

Izometrie
 $\alpha(\text{inf}, 30, 70)$
 $S[-10, 0, 0]$
 $A[0, 0, 50]$
 $v=70$

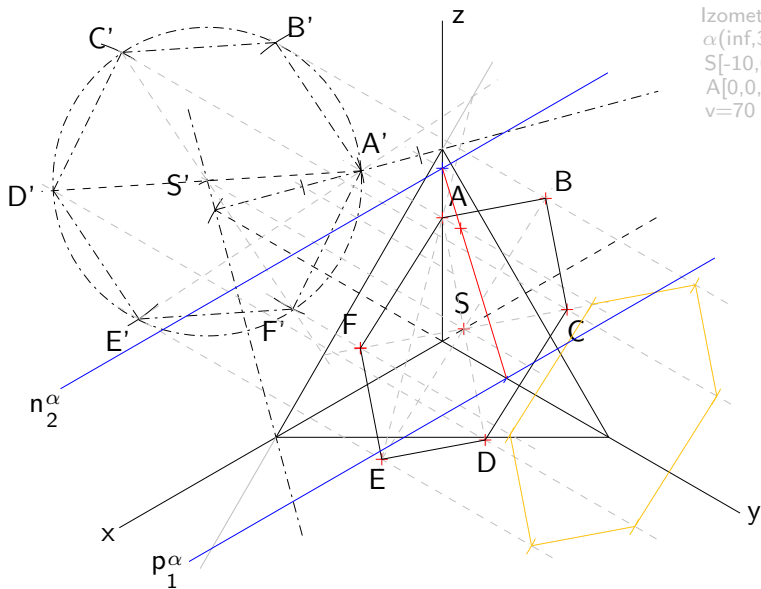

Kolmá axonometrie - řez hranolu

Izometrie
 $\alpha(\text{inf}, 30, 70)$
 $S[-10, 0, 0]$
 $A[0, 0, 50]$
 $v=70$

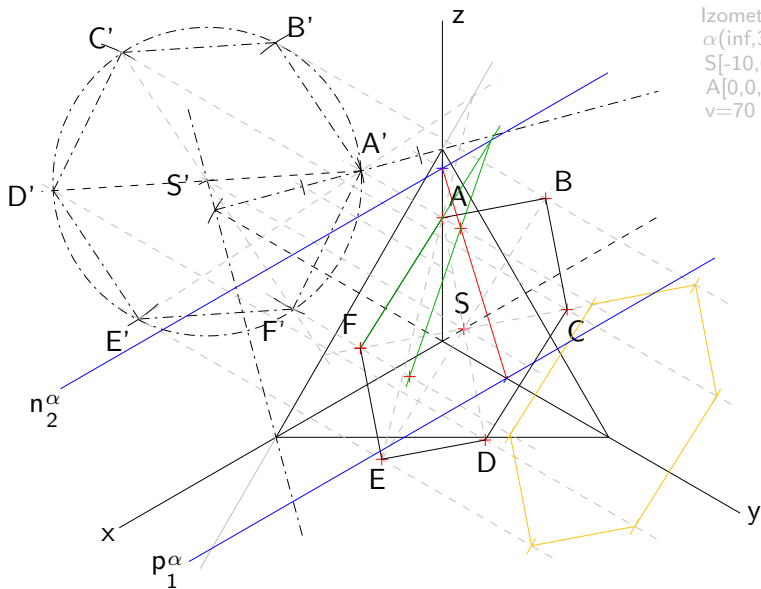

Kolmá axonometrie - řez hranolu

Izometrie
 $\alpha(\text{inf}, 30, 70)$
 $S[-10, 0, 0]$
 $A[0, 0, 50]$
 $v=70$

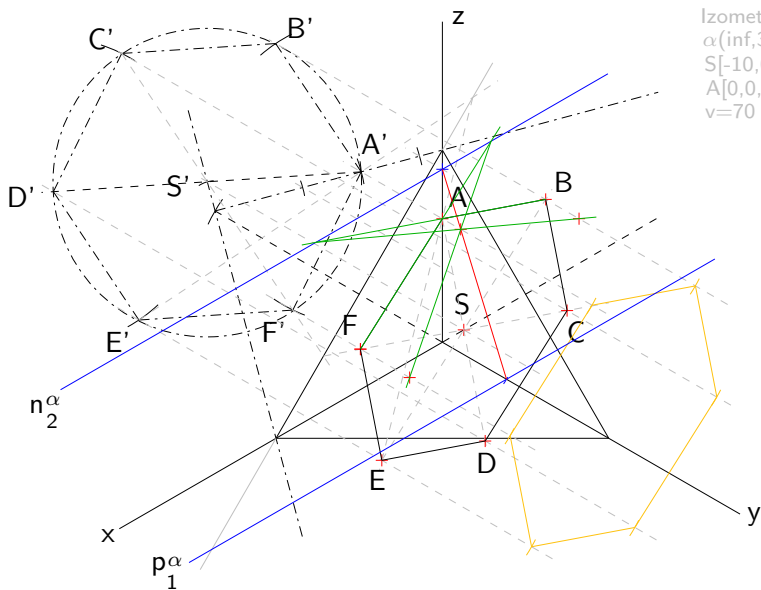

Kolmá axonometrie - řez hranolu

Izometrie
 $\alpha(\text{inf}, 30, 70)$
 $S[-10, 0, 0]$
 $A[0, 0, 50]$
 $v=70$

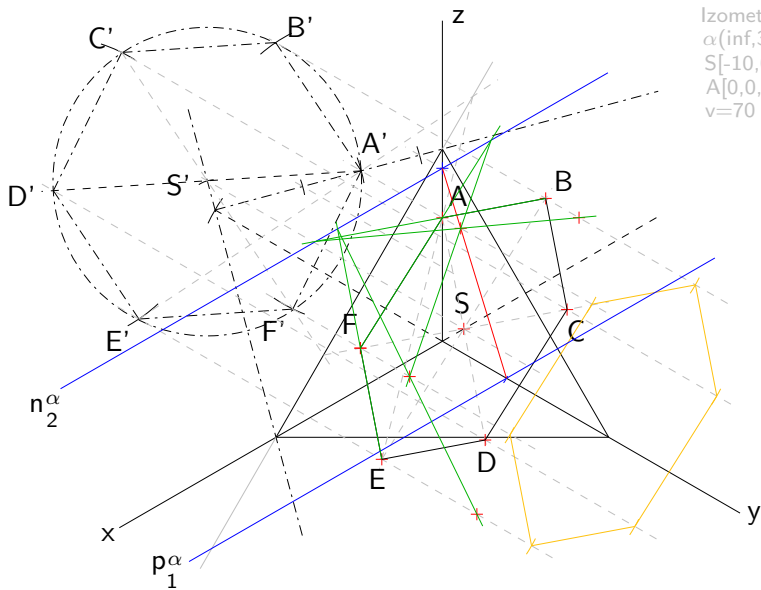

Kolmá axonometrie - řez hranolu

Izometrie
 $\alpha(\text{inf}, 30, 70)$
 $S[-10, 0, 0]$
 $A[0, 0, 50]$
 $v=70$

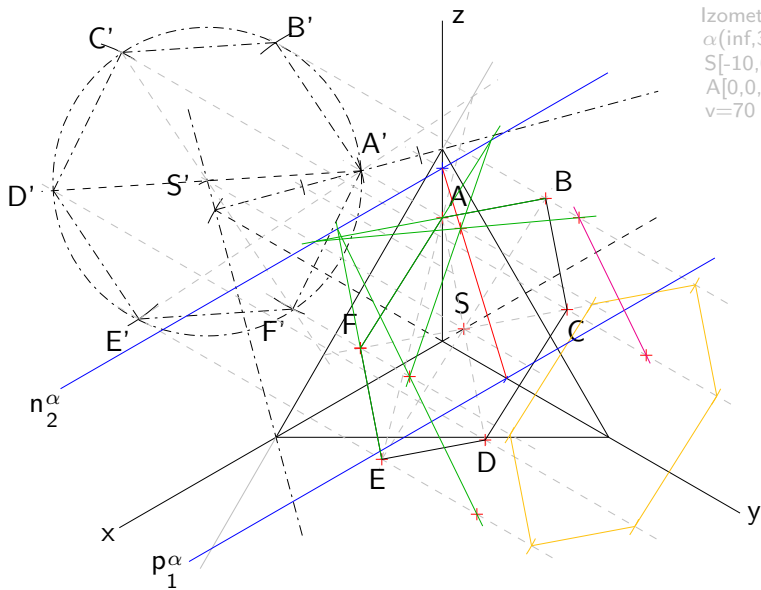

Kolmá axonometrie - řez hranolu

Izometrie
 $\alpha(\text{inf}, 30, 70)$
 $S[-10, 0, 0]$
 $A[0, 0, 50]$
 $v=70$

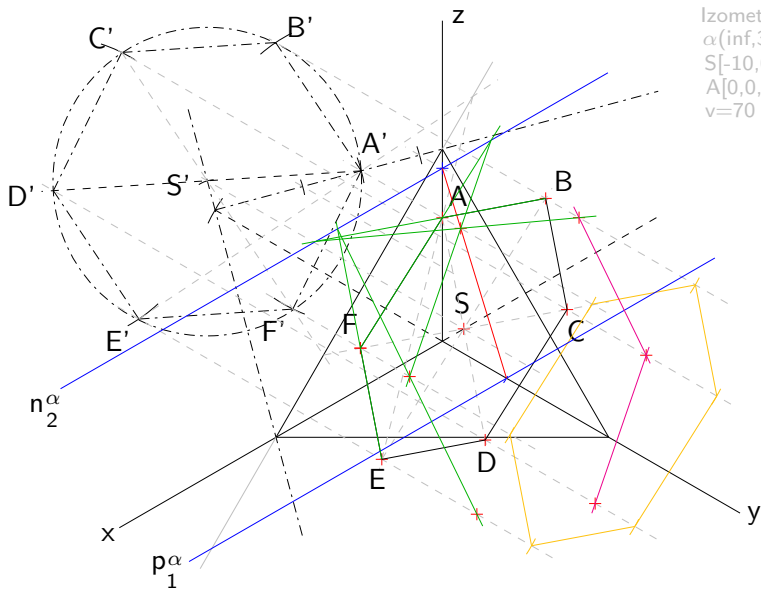

Kolmá axonometrie - řez hranolu

Izometrie
 $\alpha(\text{inf}, 30, 70)$
 $S[-10, 0, 0]$
 $A[0, 0, 50]$
 $v=70$

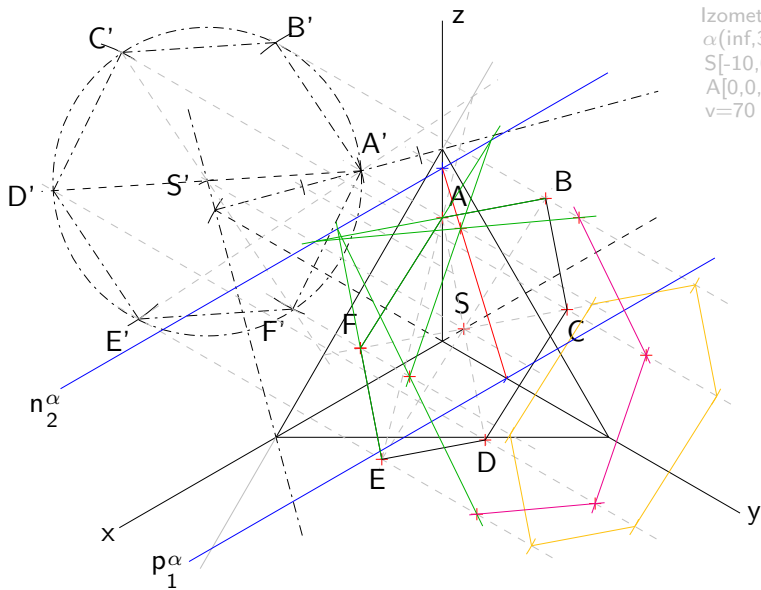

Kolmá axonometrie - řez hranolu

Izometrie
 $\alpha(\text{inf}, 30, 70)$
 $S[-10, 0, 0]$
 $A[0, 0, 50]$
 $v=70$

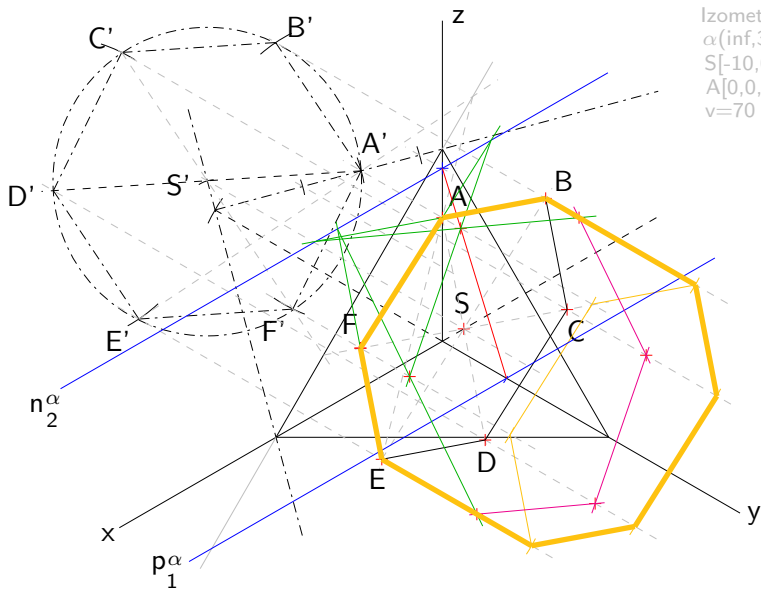

Kolmá axonometrie - řez hranolu

Izometrie
 $\alpha(\text{inf}, 30, 70)$
 $S[-10, 0, 0]$
 $A[0, 0, 50]$
 $v=70$

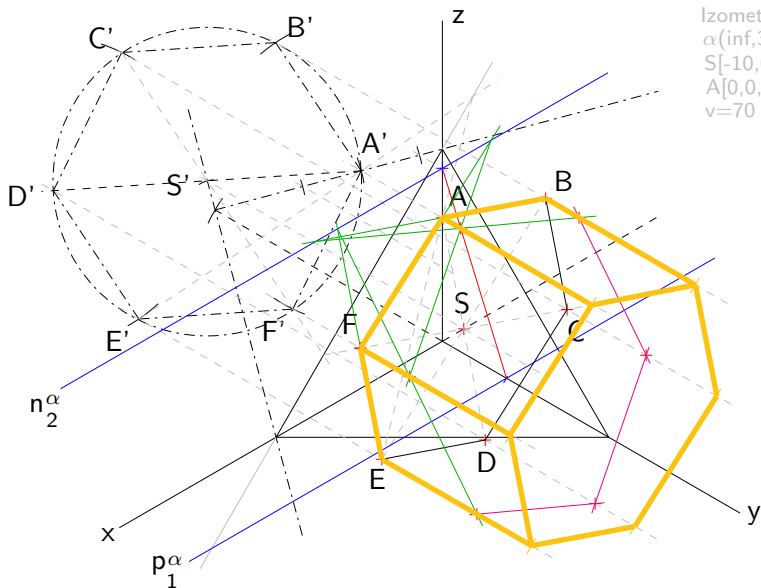

Kolmá axonometrie - řez hranolu

Izometrie
 $\alpha(\text{inf}, 30, 70)$
 $S[-10, 0, 0]$
 $A[0, 0, 50]$
 $v=70$

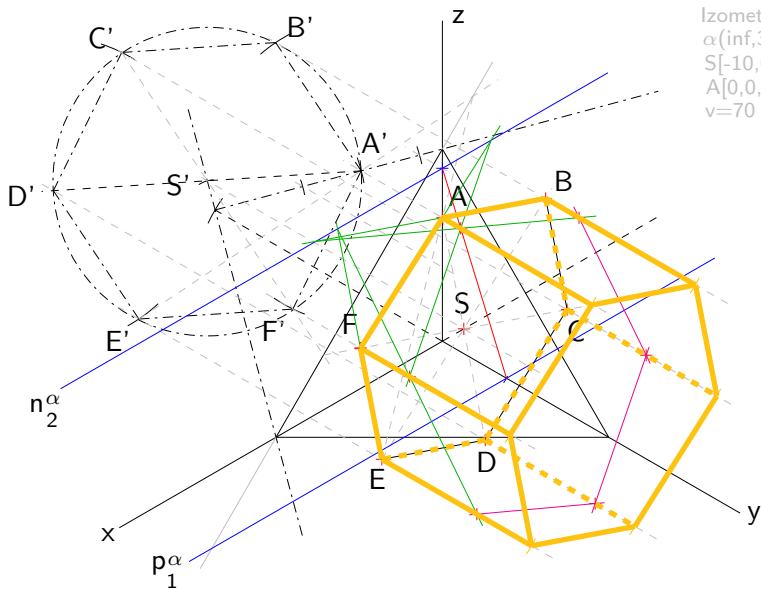

Kolmá axonometrie - řez hranolu

Izometrie
 $\alpha(\text{inf}, 30, 70)$
 $S[-10, 0, 0]$
 $A[0, 0, 50]$
 $v=70$

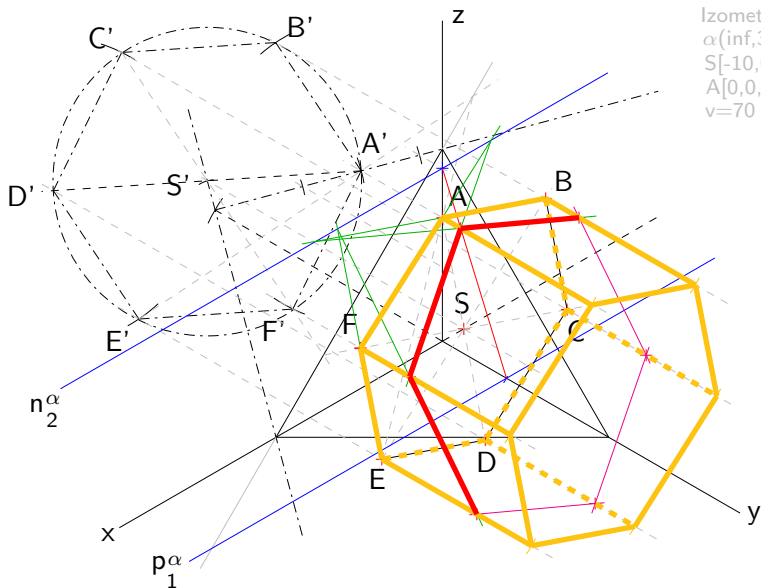

Kolmá axonometrie - řez hranolu

Izometrie
 $\alpha(\text{inf}, 30, 70)$
 $S[-10, 0, 0]$
 $A[0, 0, 50]$
 $v=70$

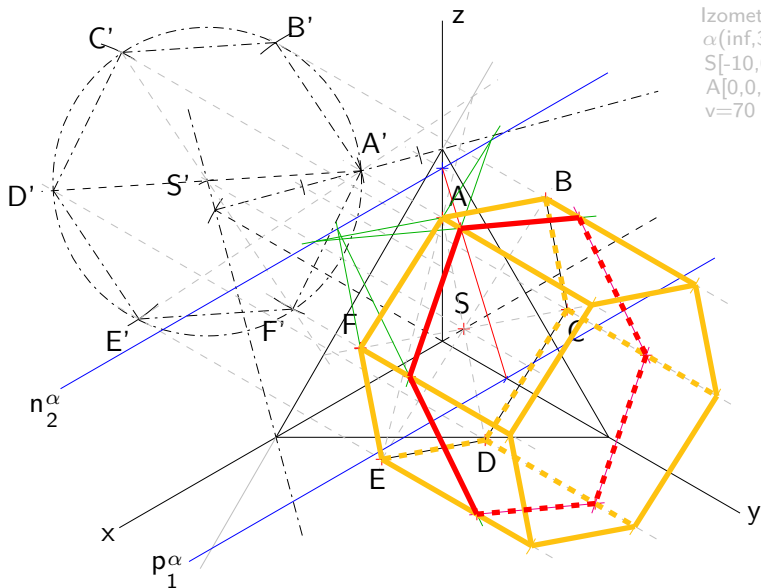

Kolmá axonometrie - řez válce

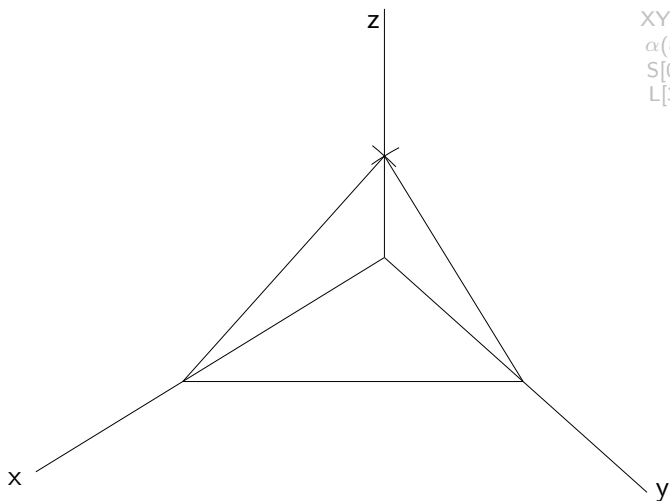

XYZ(90,80,70)
 $\alpha(80,\text{inf},30)$
S[0,0,0]
L[35,20,0]

Kolmá axonometrie - řez válce

$XYZ(90,80,70)$
 $\alpha(80,\text{inf},30)$
 $S[0,0,0]$
 $L[35,20,0]$

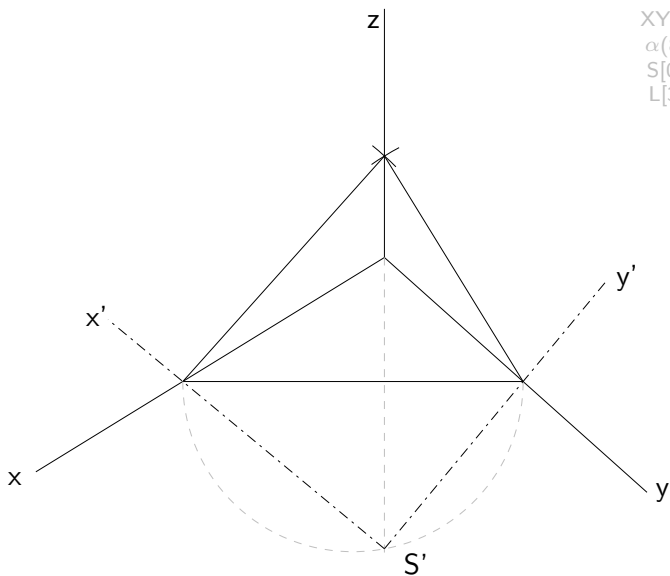

Kolmá axonometrie - řez válce

$XYZ(90,80,70)$
 $\alpha(80,\text{inf},30)$
 $S[0,0,0]$
 $L[35,20,0]$

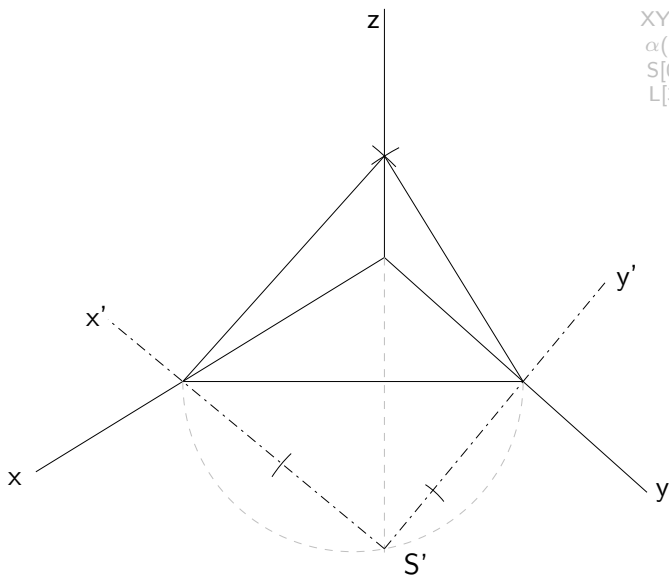

Kolmá axonometrie - řez válce

$XYZ(90,80,70)$
 $\alpha(80,\text{inf},30)$
 $S[0,0,0]$
 $L[35,20,0]$

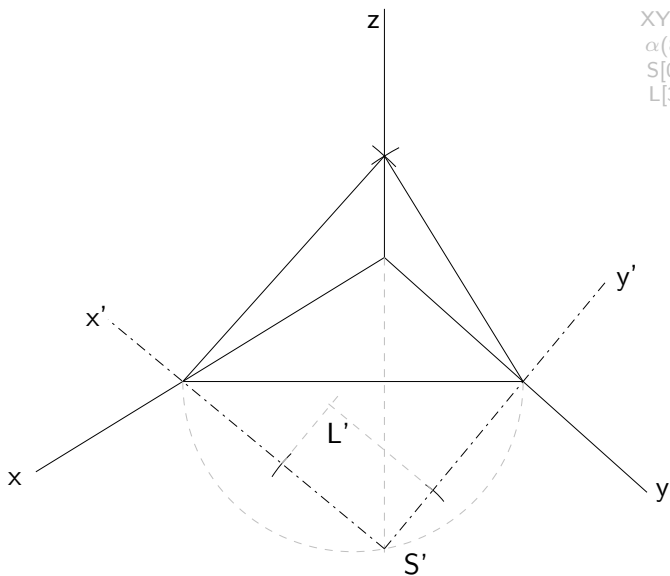

Kolmá axonometrie - řez válce

$XYZ(90,80,70)$
 $\alpha(80,\text{inf},30)$
 $S[0,0,0]$
 $L[35,20,0]$

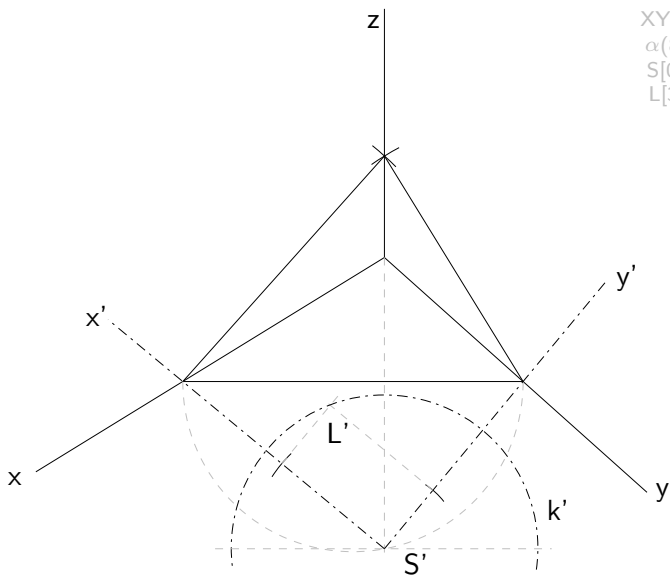

Kolmá axonometrie - řez válce

$XYZ(90,80,70)$
 $\alpha(80,\text{inf},30)$
 $S[0,0,0]$
 $L[35,20,0]$

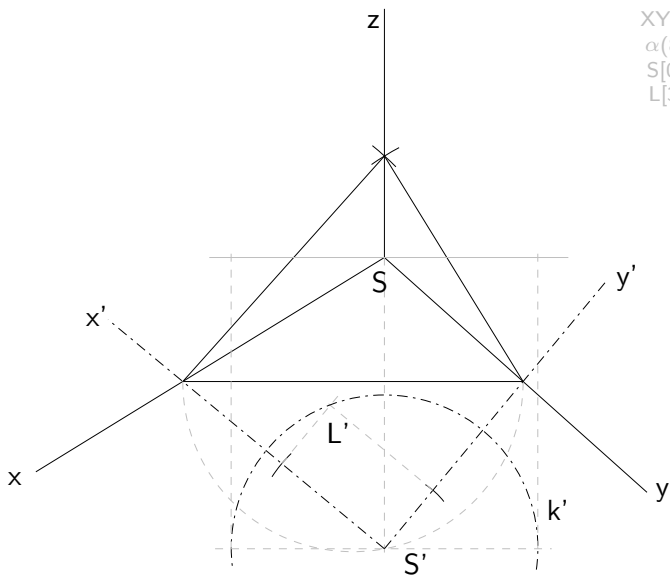

Kolmá axonometrie - řez válce

$XYZ(90,80,70)$
 $\alpha(80,\text{inf},30)$
 $S[0,0,0]$
 $L[35,20,0]$

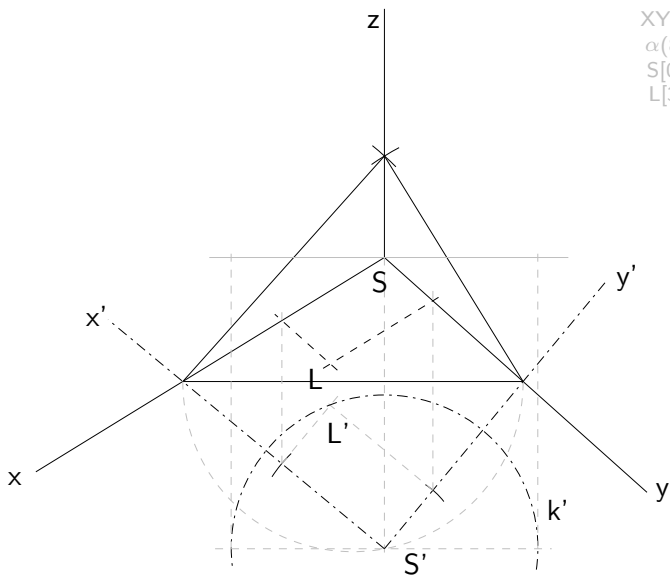

Kolmá axonometrie - řez válce

$XYZ(90,80,70)$
 $\alpha(80,inf,30)$
 $S[0,0,0]$
 $L[35,20,0]$

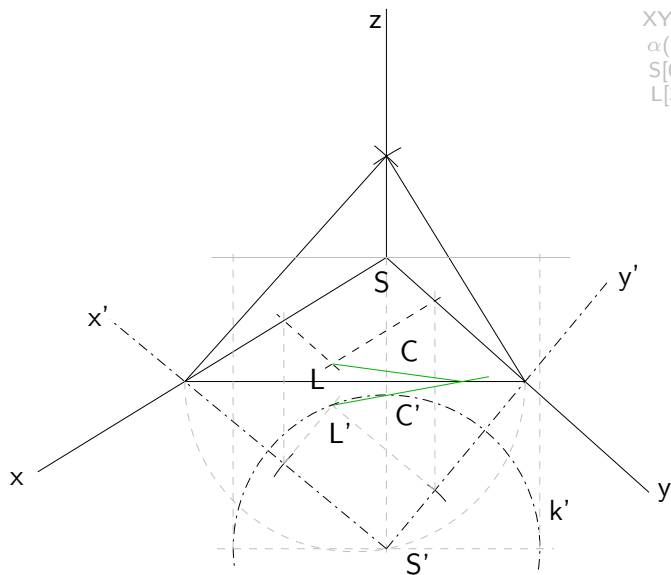

Kolmá axonometrie - řez válce

$XYZ(90,80,70)$
 $\alpha(80,inf,30)$
 $S[0,0,0]$
 $L[35,20,0]$

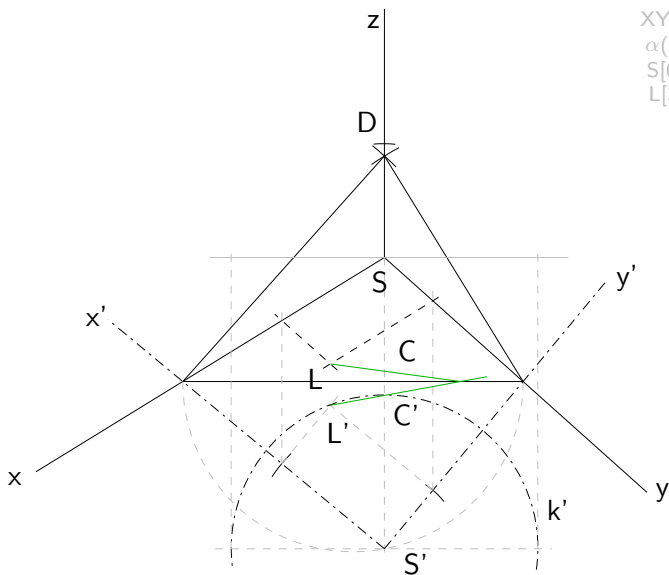

Kolmá axonometrie - řez válce

$XYZ(90,80,70)$
 $\alpha(80,\text{inf},30)$
 $S[0,0,0]$
 $L[35,20,0]$

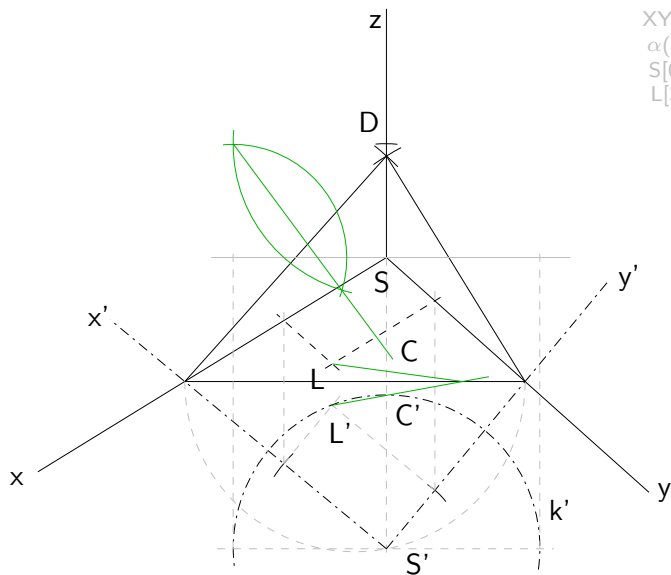

Kolmá axonometrie - řez válce

$XYZ(90,80,70)$
 $\alpha(80,\text{inf},30)$
 $S[0,0,0]$
 $L[35,20,0]$

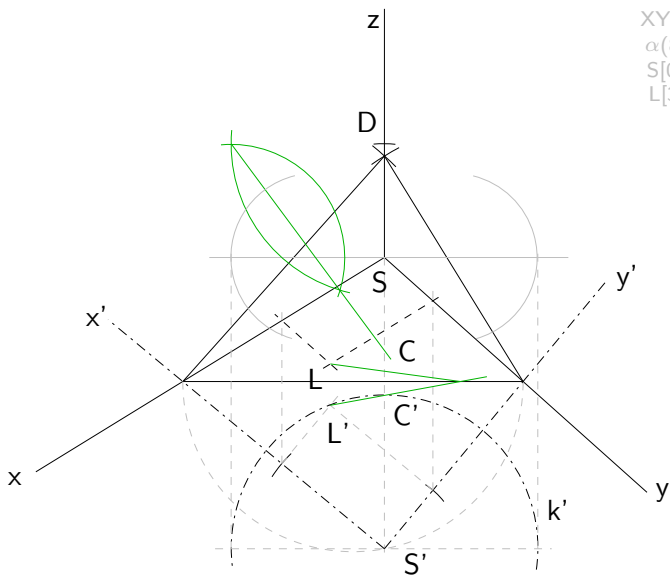

Kolmá axonometrie - řez válce

XYZ(90,80,70)
 $\alpha(80,\text{inf},30)$
S[0,0,0]
L[35,20,0]

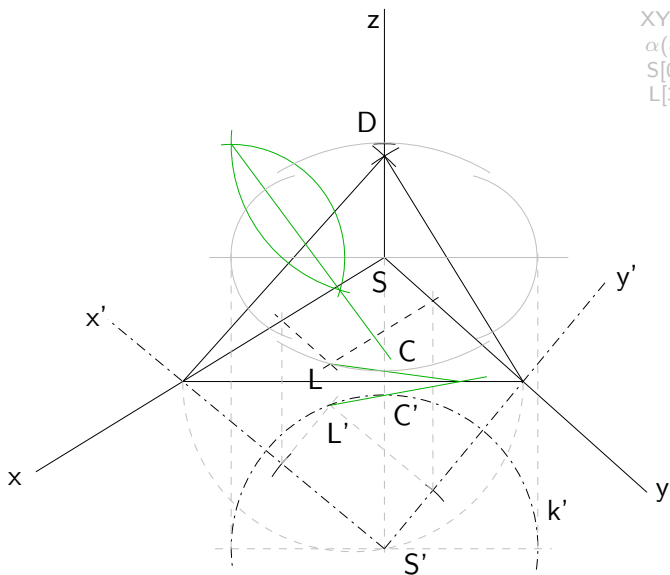

Kolmá axonometrie - řez válce

$XYZ(90,80,70)$
 $\alpha(80,\text{inf},30)$
 $S[0,0,0]$
 $L[35,20,0]$

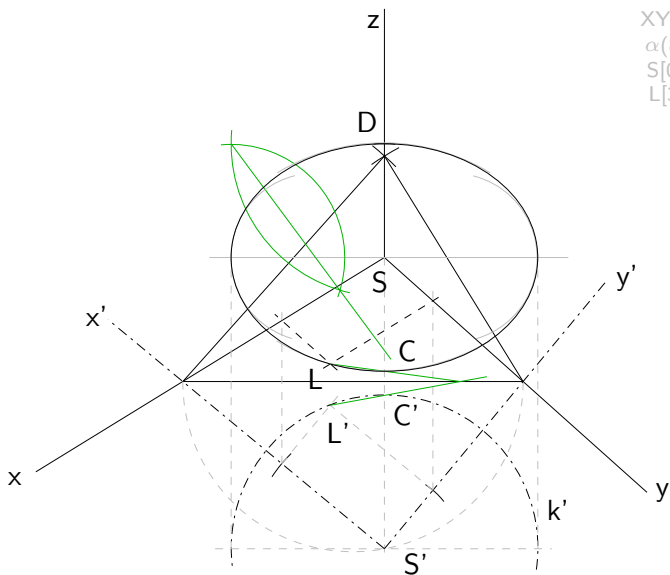

Kolmá axonometrie - řez válce

$XYZ(90,80,70)$
 $\alpha(80,\text{inf},30)$
 $S[0,0,0]$
 $L[35,20,0]$

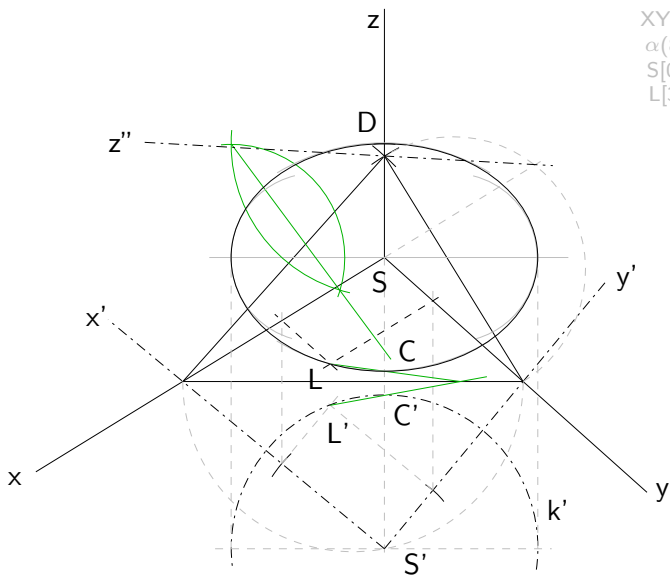

Kolmá axonometrie - řez válce

$XYZ(90,80,70)$
 $\alpha(80,\text{inf},30)$
 $S[0,0,0]$
 $L[35,20,0]$

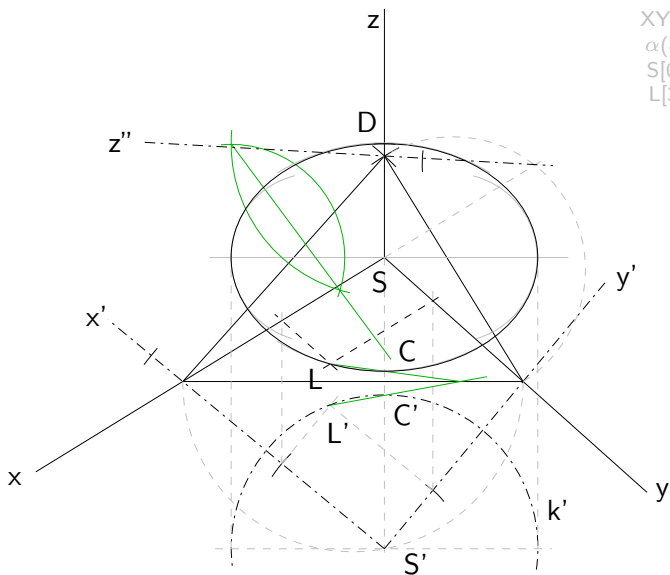

Kolmá axonometrie - řez válce

XYZ(90,80,70)
 $\alpha(80, \text{inf}, 30)$
S[0,0,0]
L[35,20,0]

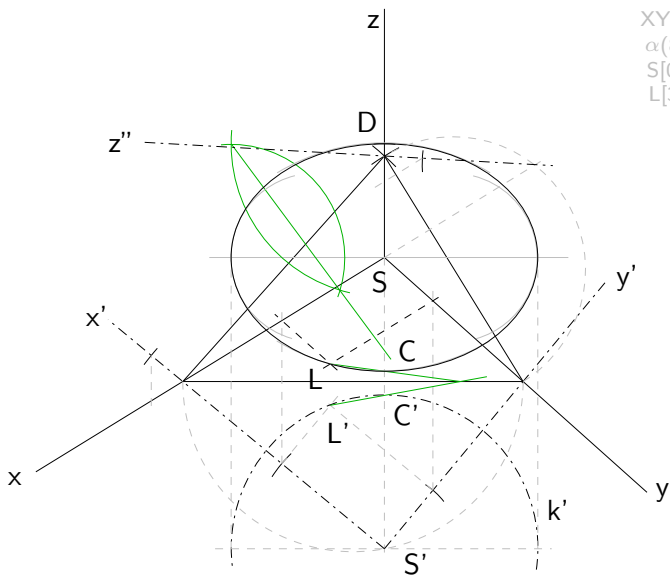

Kolmá axonometrie - řez válce

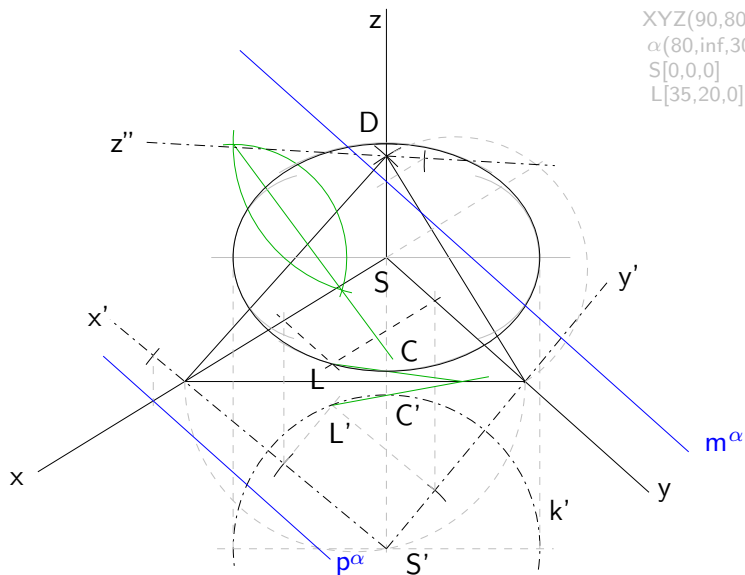

Kolmá axonometrie - řez válce

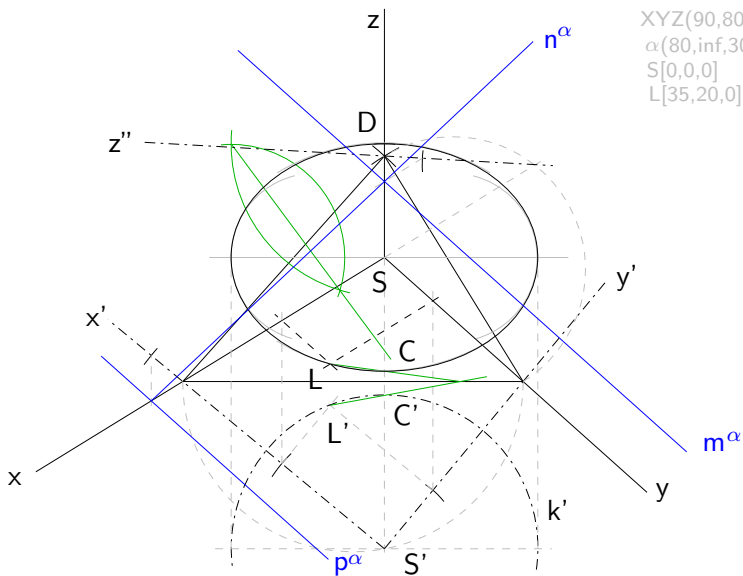

Kolmá axonometrie - řez válce

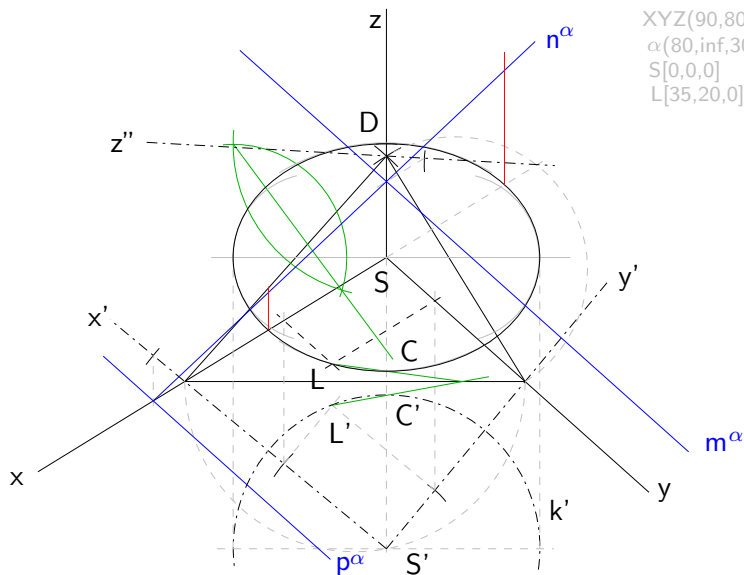

$XYZ(90, 80, 70)$
 $\alpha(80, \text{inf}, 30)$
 $S[0, 0, 0]$
 $L[35, 20, 0]$

Kolmá axonometrie - řez válce

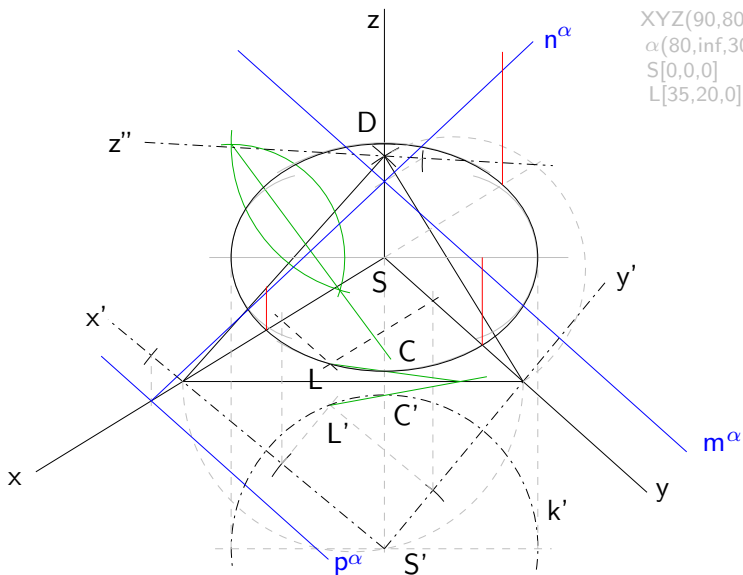

$XYZ(90,80,70)$
 $\alpha(80,\text{inf},30)$
 $S[0,0,0]$
 $L[35,20,0]$

Kolmá axonometrie - řez válce

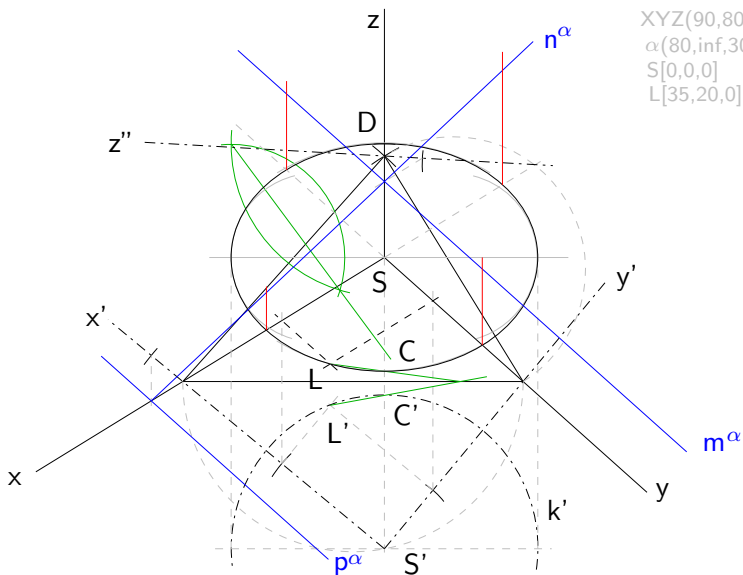

$XYZ(90,80,70)$
 $\alpha(80,\text{inf},30)$
 $S[0,0,0]$
 $L[35,20,0]$

Kolmá axonometrie - řez válce

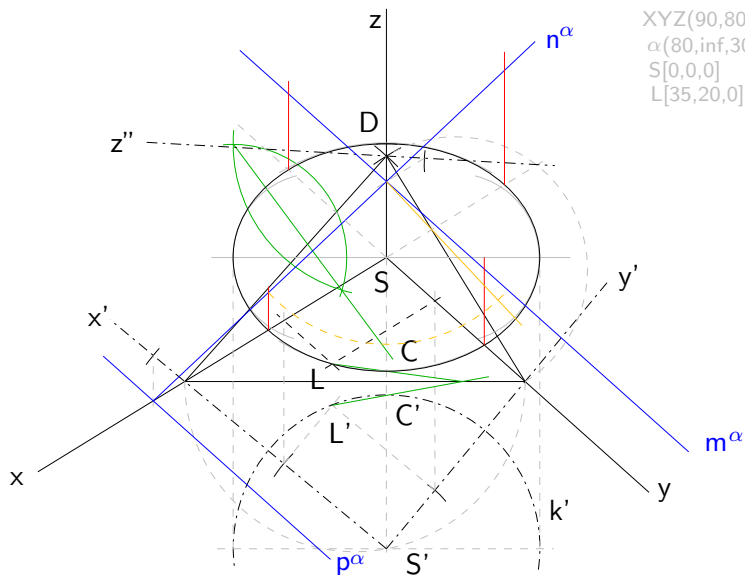

Kolmá axonometrie - řez válce

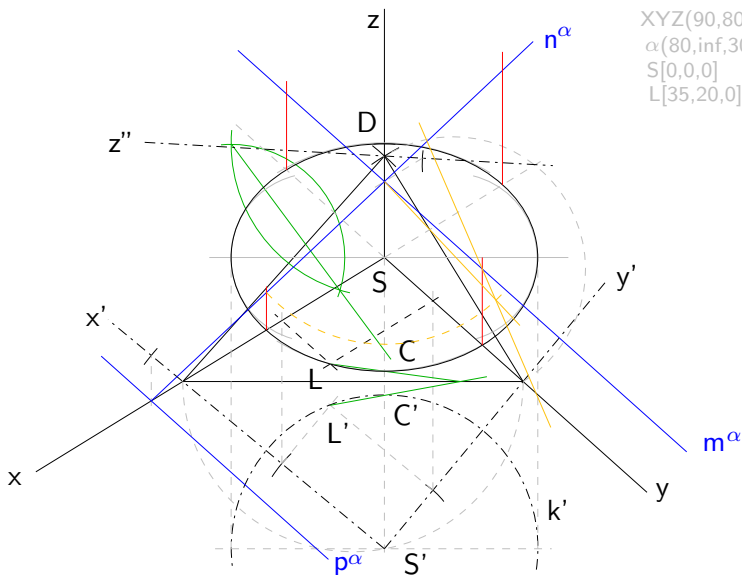

Kolmá axonometrie - řez válce

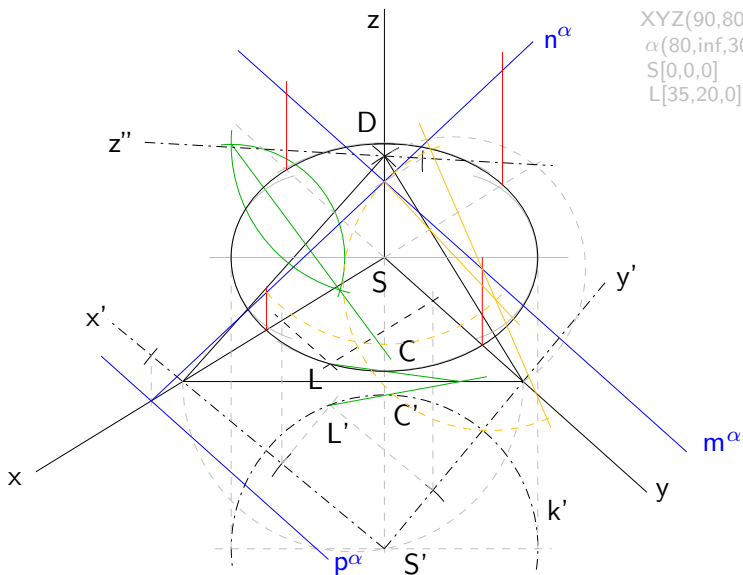

$XYZ(90,80,70)$
 $\alpha(80,\text{inf},30)$
 $S[0,0,0]$
 $L[35,20,0]$

Kolmá axonometrie - řez válce

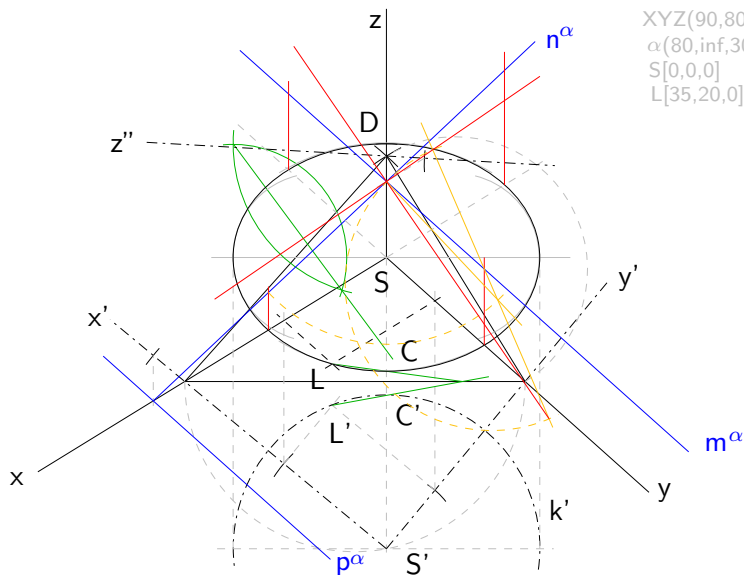

$XYZ(90,80,70)$
 $\alpha(80,\text{inf},30)$
 $S[0,0,0]$
 $L[35,20,0]$

Kolmá axonometrie - řez válce

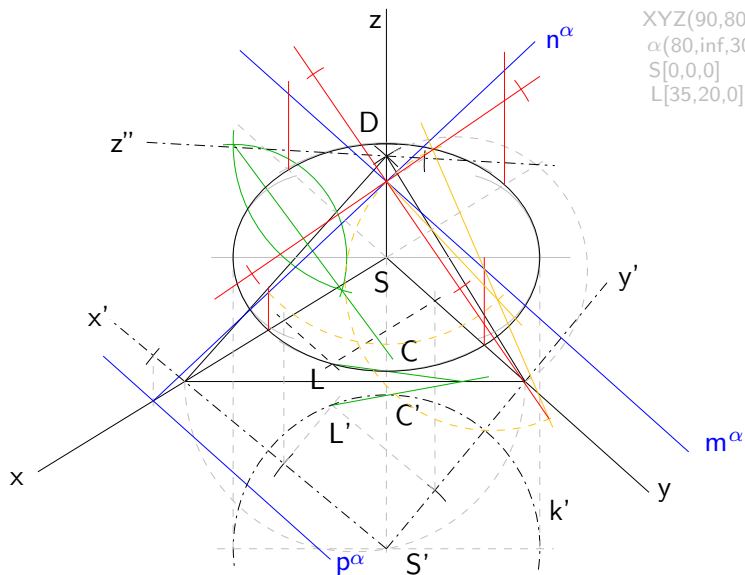

Kolmá axonometrie - řez válce

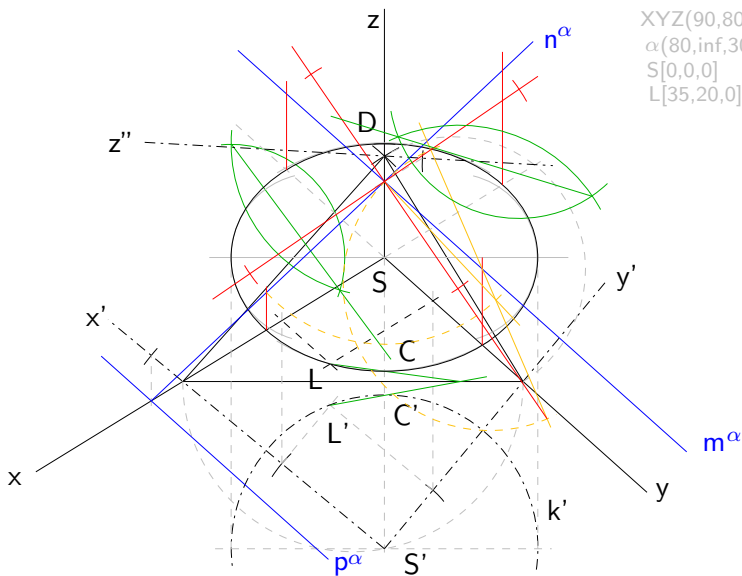

$XYZ(90,80,70)$
 $\alpha(80,inf,30)$
 $S[0,0,0]$
 $L[35,20,0]$

Kolmá axonometrie - řez válce

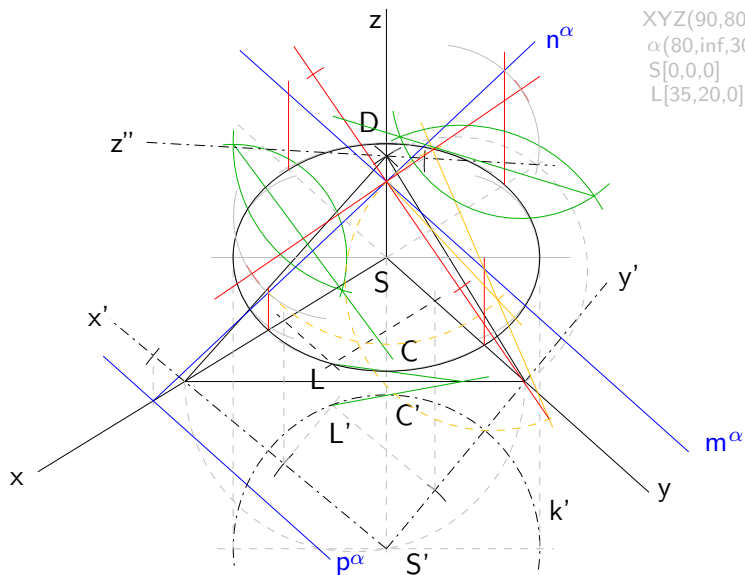

Kolmá axonometrie - řez válce

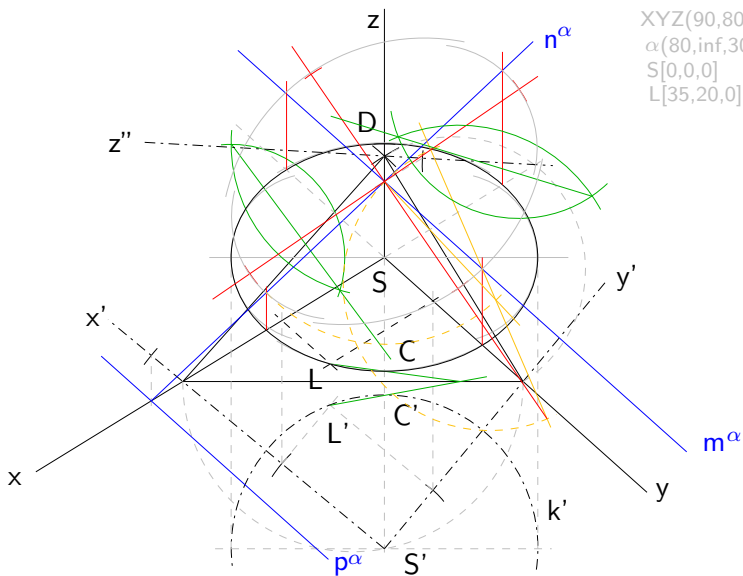

Kolmá axonometrie - řez válce

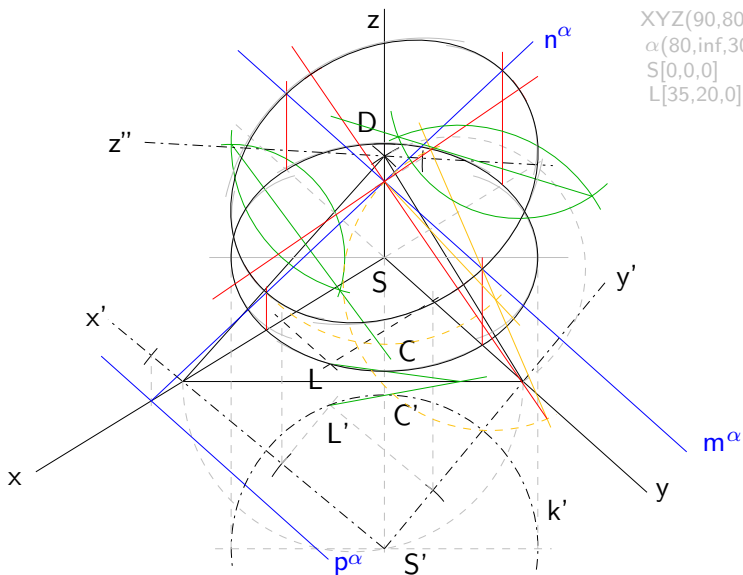

$XYZ(90,80,70)$
 $\alpha(80,inf,30)$
 $S[0,0,0]$
 $L[35,20,0]$

Kolmá axonometrie - řez válce

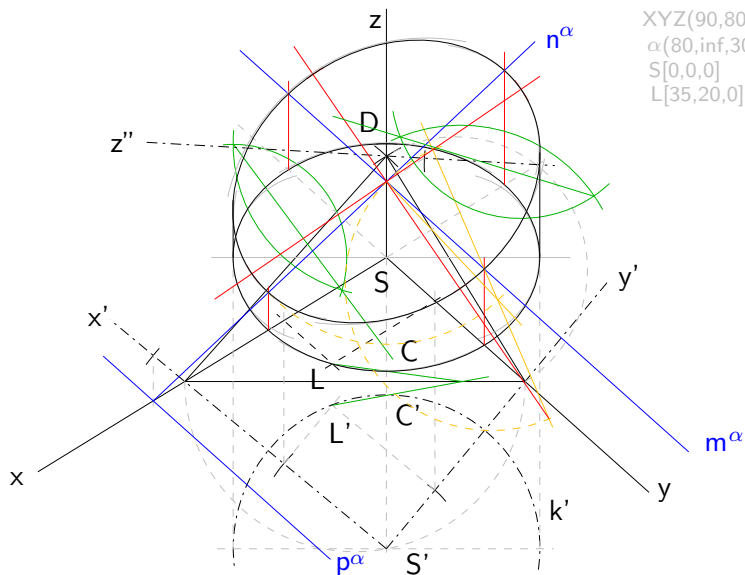

$XYZ(90,80,70)$
 $\alpha(80,inf,30)$
 $S[0,0,0]$
 $L[35,20,0]$

Kolmá axonometrie - řez válce

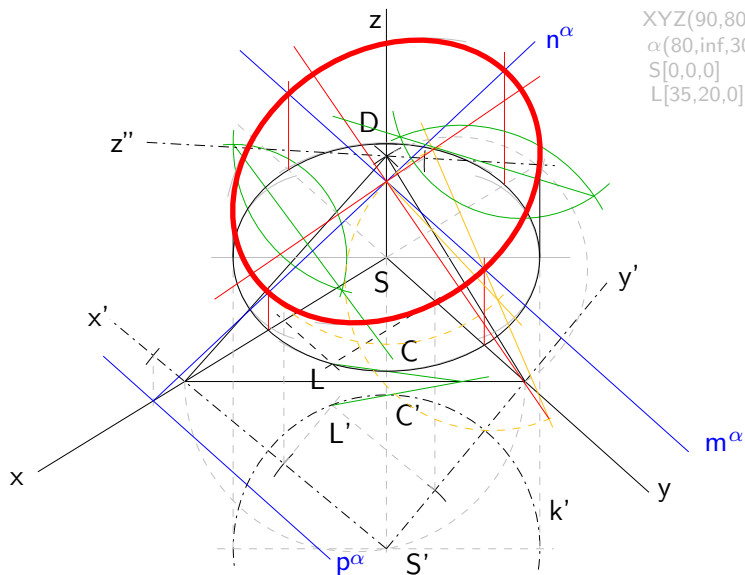

Kolmá axonometrie - řez válce

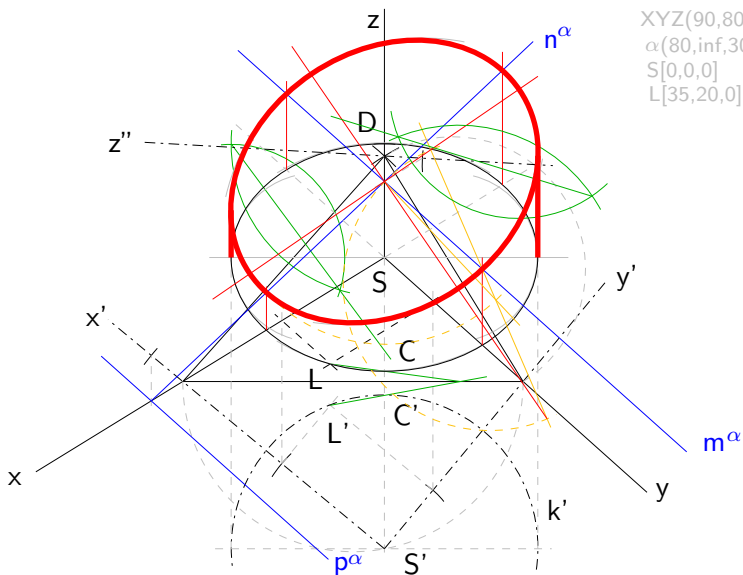

Kolmá axonometrie - řez válce

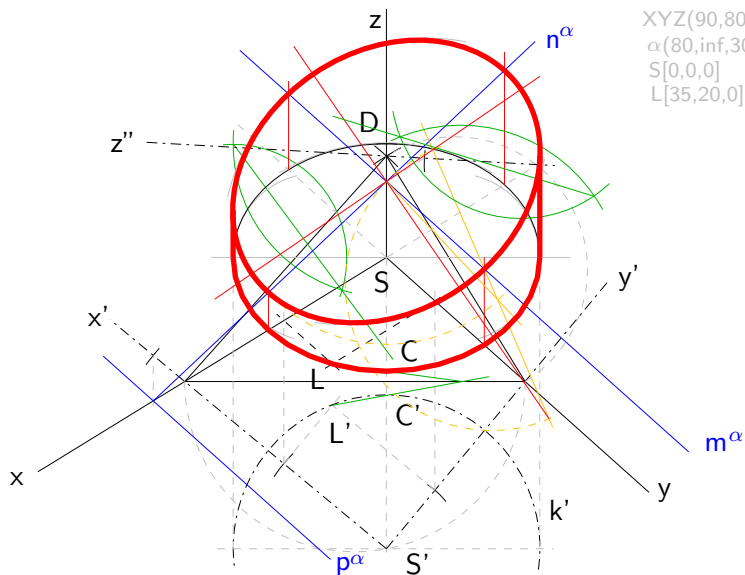

$XYZ(90,80,70)$
 $\alpha(80,inf,30)$
 $S[0,0,0]$
 $L[35,20,0]$

Kolmá axonometrie - řez válce

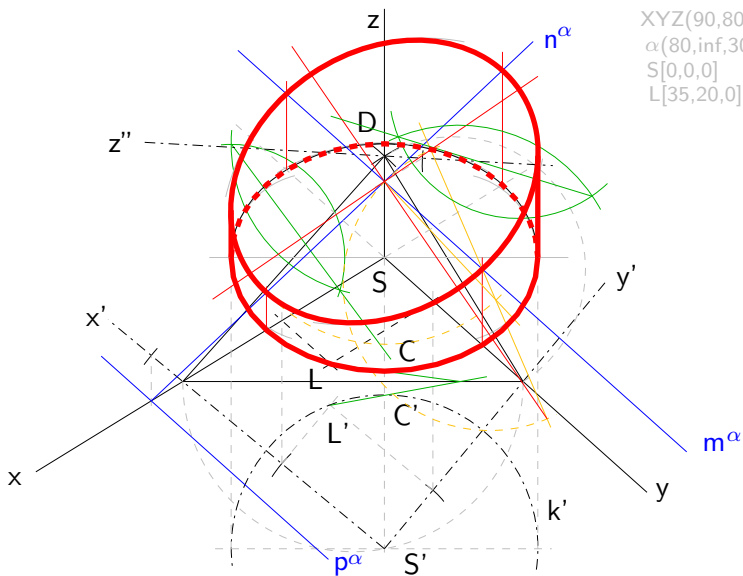

$XYZ(90,80,70)$
 $\alpha(80,\text{inf},30)$
 $S[0,0,0]$
 $L[35,20,0]$

Mongeovo promítání - jehlan a přímka

V[10,70,100]
A[-40,0,20]
C[40,0,70]
N[70,0,30]
Q[-50,40,90]
a=NQ

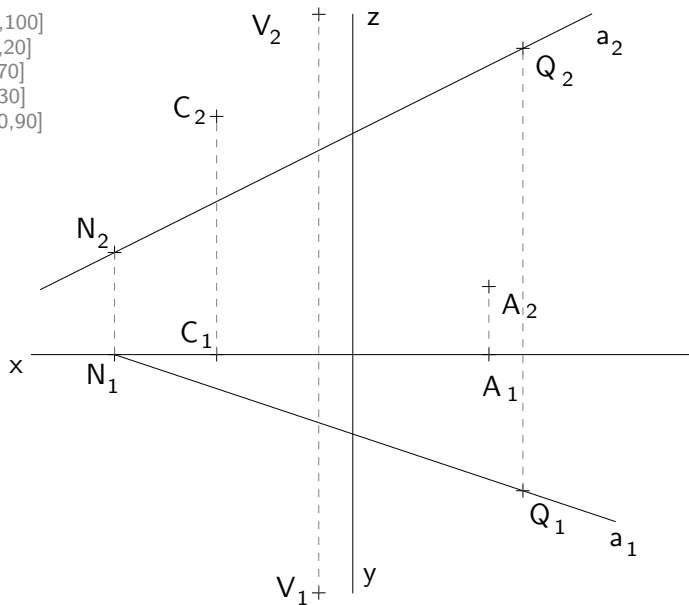

Mongeovo promítání - jehlan a přímka

V[10,70,100]
A[-40,0,20]
C[40,0,70]
N[70,0,30]
Q[-50,40,90]
a=NQ

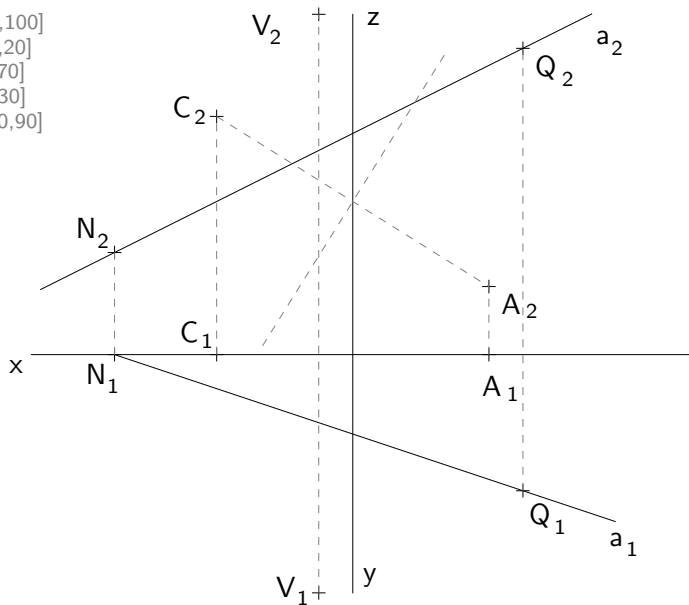

Mongeovo promítání - jehlan a přímka

V[10,70,100]
A[-40,0,20]
C[40,0,70]
N[70,0,30]
Q[-50,40,90]
a=NQ

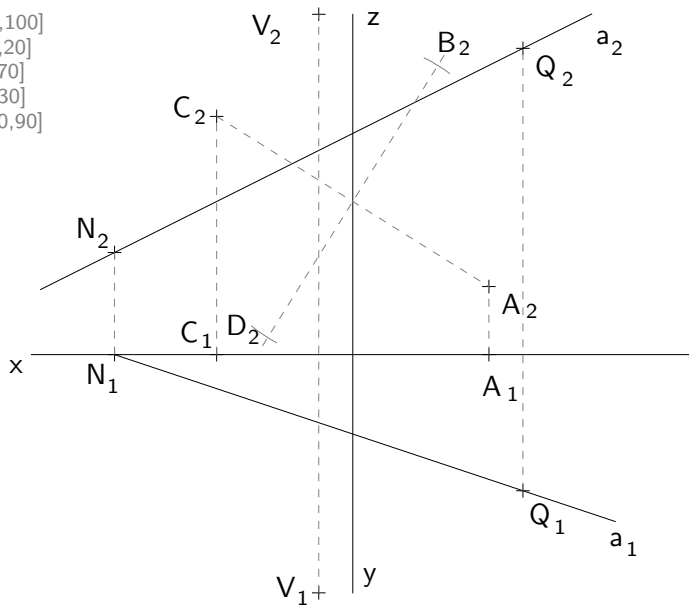

Mongeovo promítání - jehlan a přímka

V[10,70,100]
A[-40,0,20]
C[40,0,70]
N[70,0,30]
Q[-50,40,90]
a=NQ

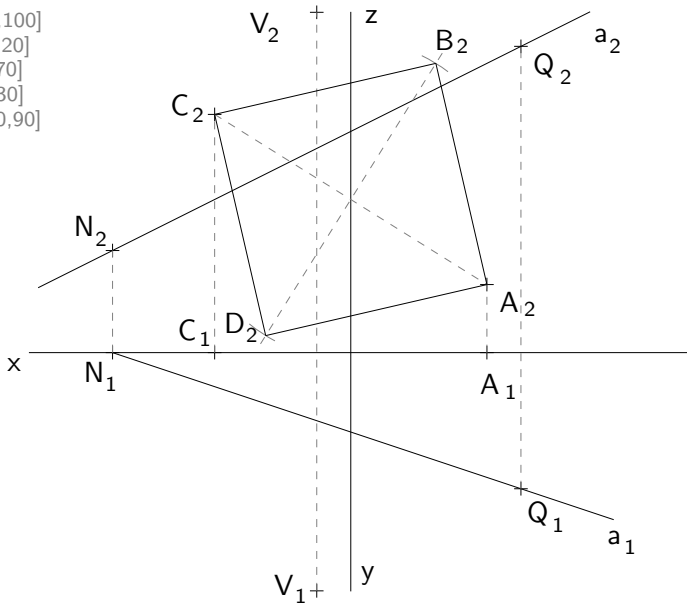

Mongeovo promítání - jehlan a přímka

V[10,70,100]
A[-40,0,20]
C[40,0,70]
N[70,0,30]
Q[-50,40,90]
a=NQ

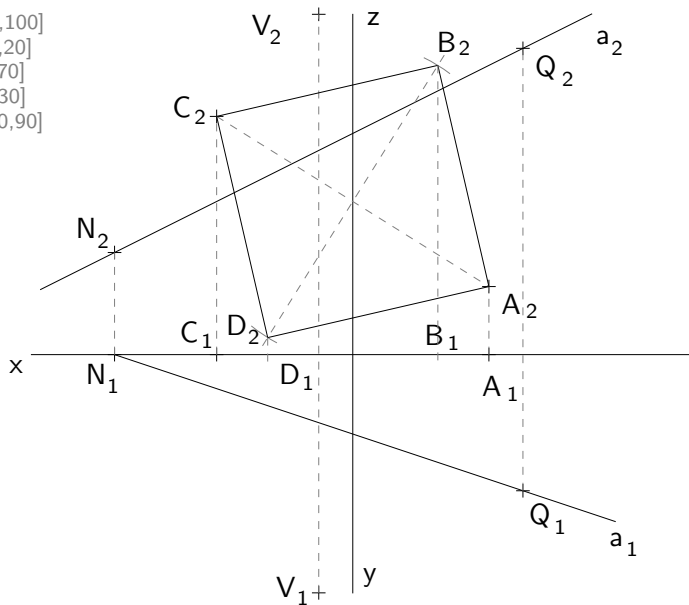

Mongeovo promítání - jehlan a přímka

V[10,70,100]
A[-40,0,20]
C[40,0,70]
N[70,0,30]
Q[-50,40,90]
a=NQ

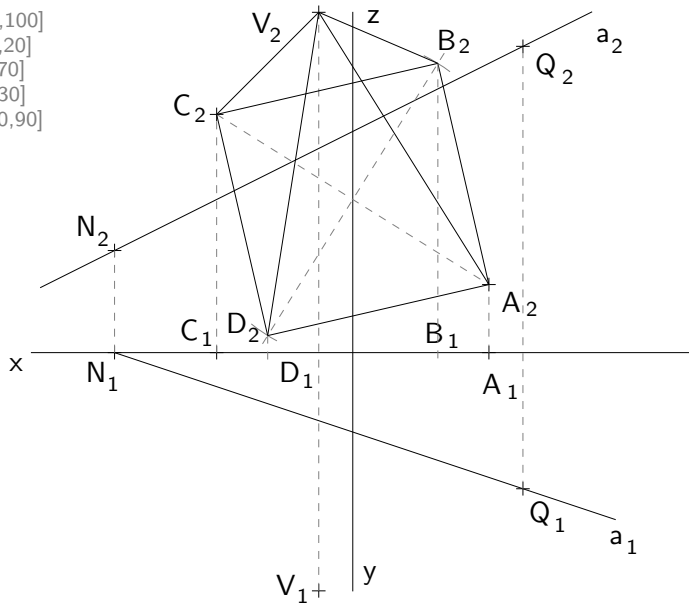

Mongeovo promítání - jehlan a přímka

V[10,70,100]
A[-40,0,20]
C[40,0,70]
N[70,0,30]
Q[-50,40,90]
a=NQ

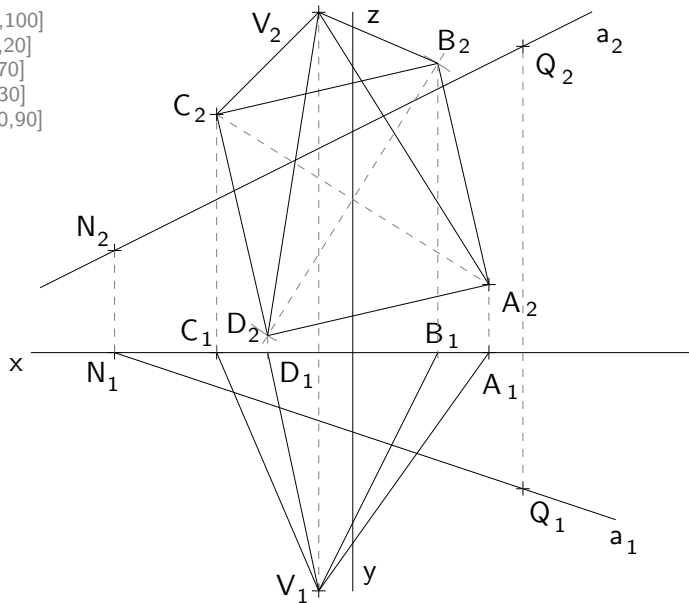

Mongeovo promítání - jehlan a přímka

$V[10,70,100]$
 $A[-40,0,20]$
 $C[40,0,70]$
 $N[70,0,30]$
 $Q[-50,40,90]$
 $a=NQ$

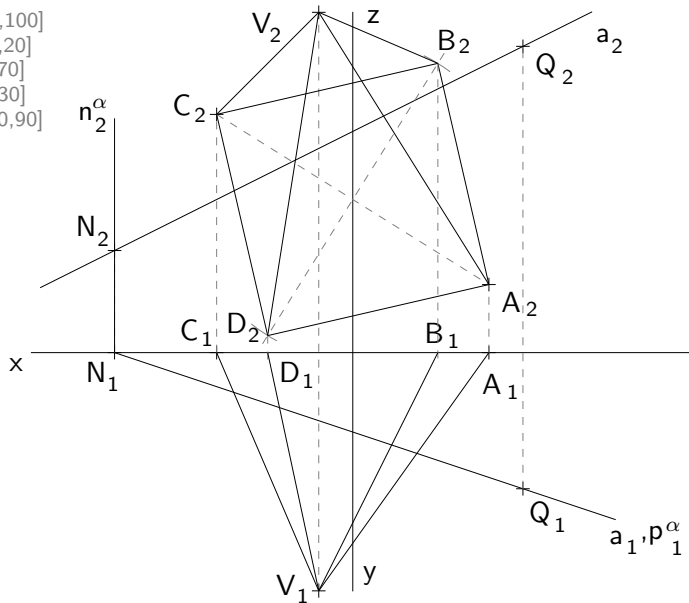

Mongeovo promítání - jehlan a přímka

$V[10,70,100]$
 $A[-40,0,20]$
 $C[40,0,70]$
 $N[70,0,30]$
 $Q[-50,40,90]$
 $a=NQ$

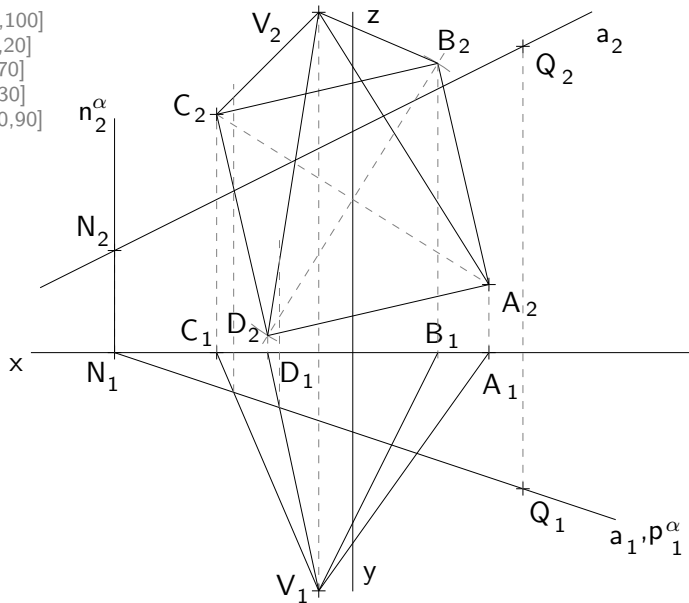

Mongeovo promítání - jehlan a přímka

V[10,70,100]
A[-40,0,20]
C[40,0,70]
N[70,0,30]
Q[-50,40,90]
a=NQ

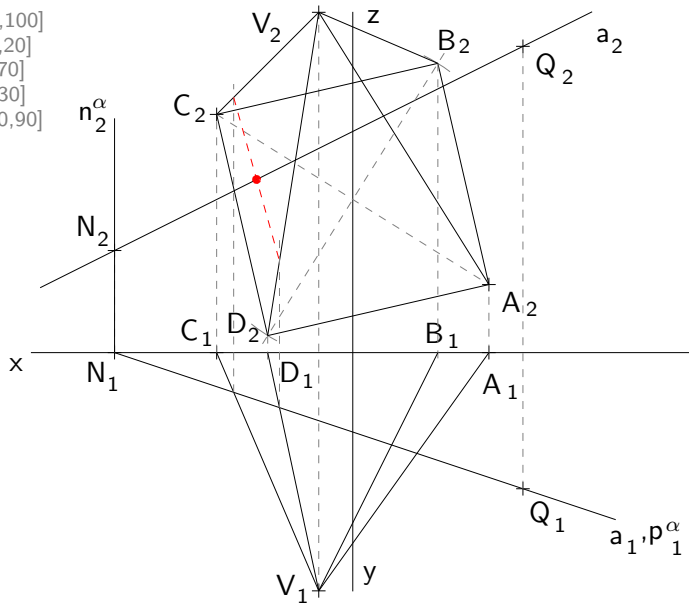

Mongeovo promítání - jehlan a přímka

V[10,70,100]
A[-40,0,20]
C[40,0,70]
N[70,0,30]
Q[-50,40,90]
a=NQ

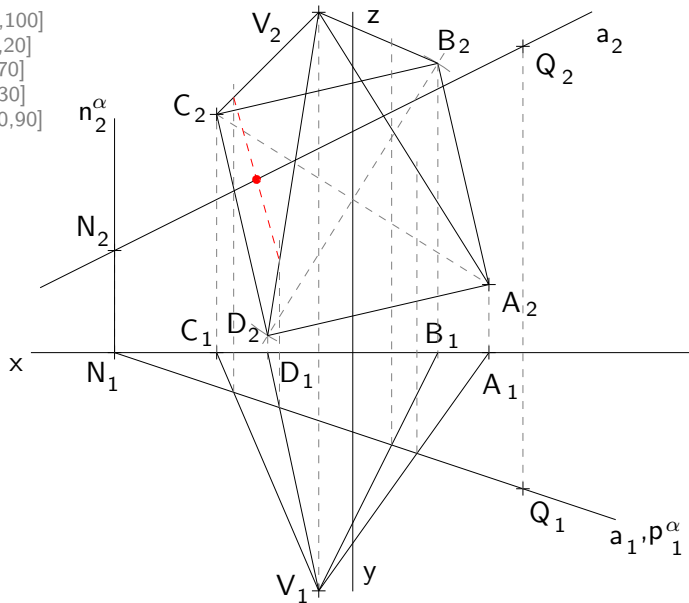

Mongeovo promítání - jehlan a přímka

V[10,70,100]
A[-40,0,20]
C[40,0,70]
N[70,0,30]
Q[-50,40,90]
a=NQ

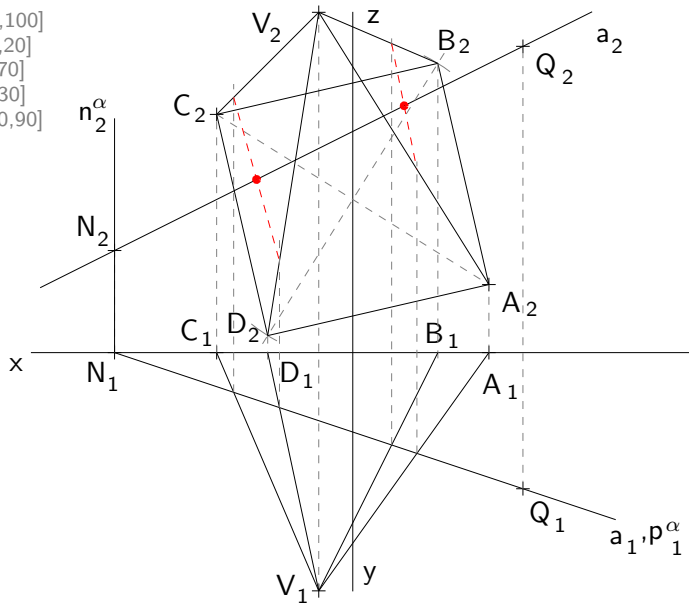

Mongeovo promítání - jehlan a přímka

V[10,70,100]
A[-40,0,20]
C[40,0,70]
N[70,0,30]
Q[-50,40,90]
a=NQ

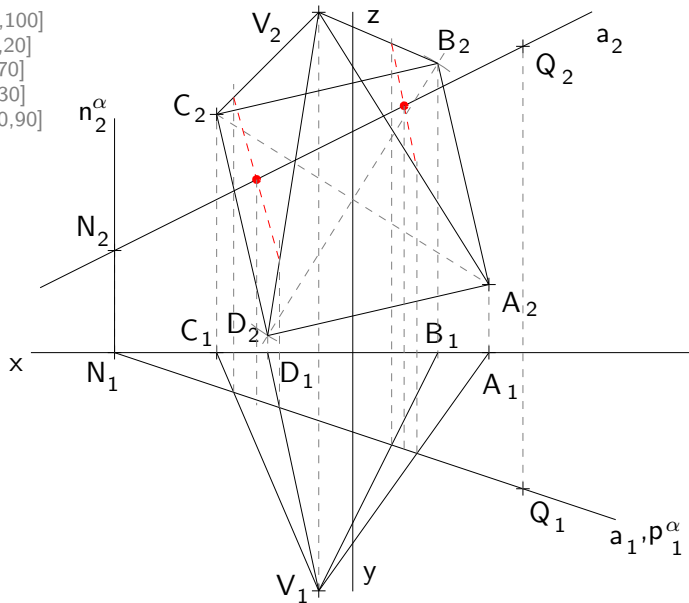

Mongeovo promítání - jehlan a přímka

V[10,70,100]
A[-40,0,20]
C[40,0,70]
N[70,0,30]
Q[-50,40,90]
a=NQ

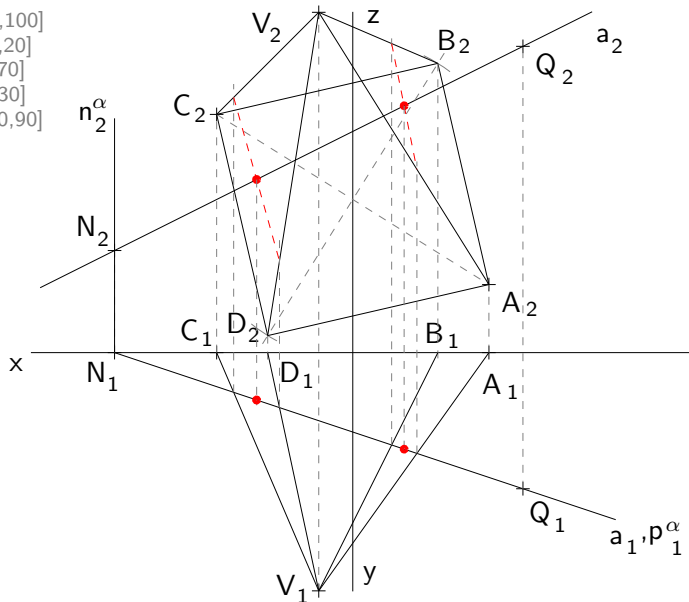

Mongeovo promítání - jehlan a přímka

V[10,70,100]
A[-40,0,20]
C[40,0,70]
N[70,0,30]
Q[-50,40,90]
a=NQ

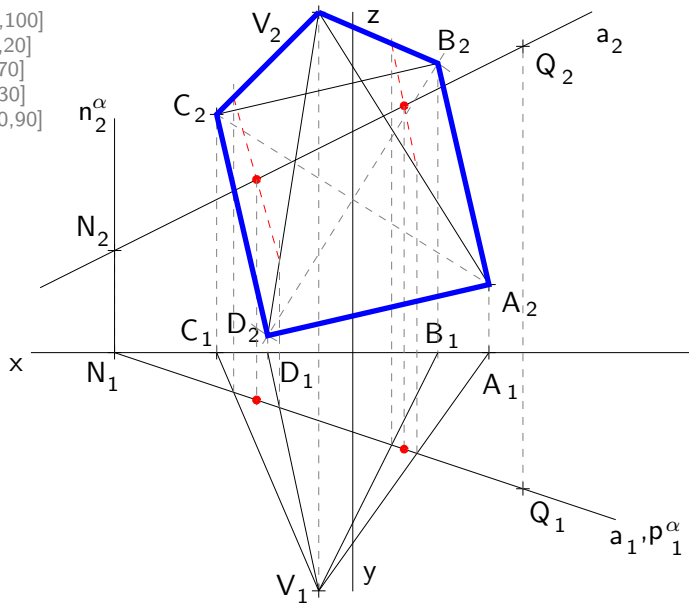

Mongeovo promítání - jehlan a přímka

V[10,70,100]
A[-40,0,20]
C[40,0,70]
N[70,0,30]
Q[-50,40,90]
a=NQ

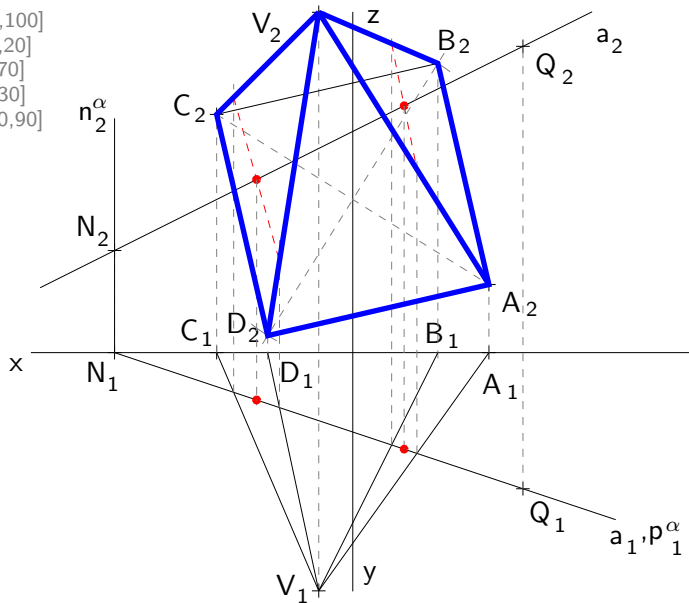

Mongeovo promítání - jehlan a přímka

$V[10,70,100]$
 $A[-40,0,20]$
 $C[40,0,70]$
 $N[70,0,30]$
 $Q[-50,40,90]$
 $a=NQ$

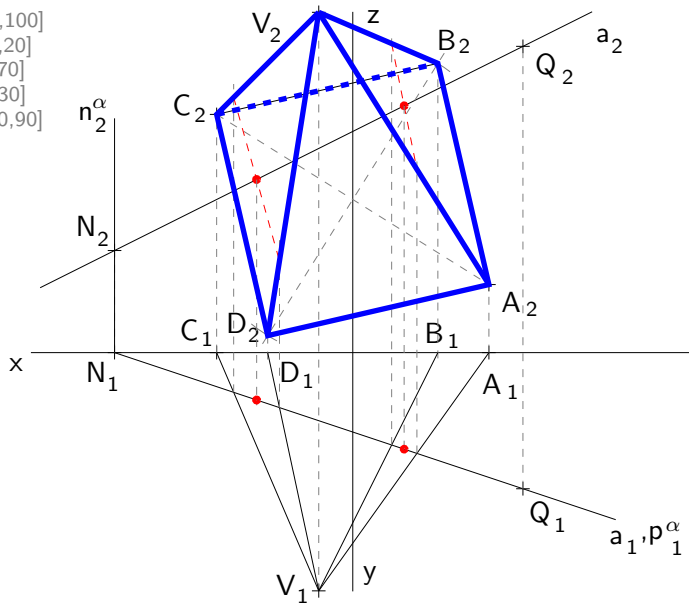

Mongeovo promítání - jehlan a přímka

V[10,70,100]
A[-40,0,20]
C[40,0,70]
N[70,0,30]
Q[-50,40,90]
a=NQ

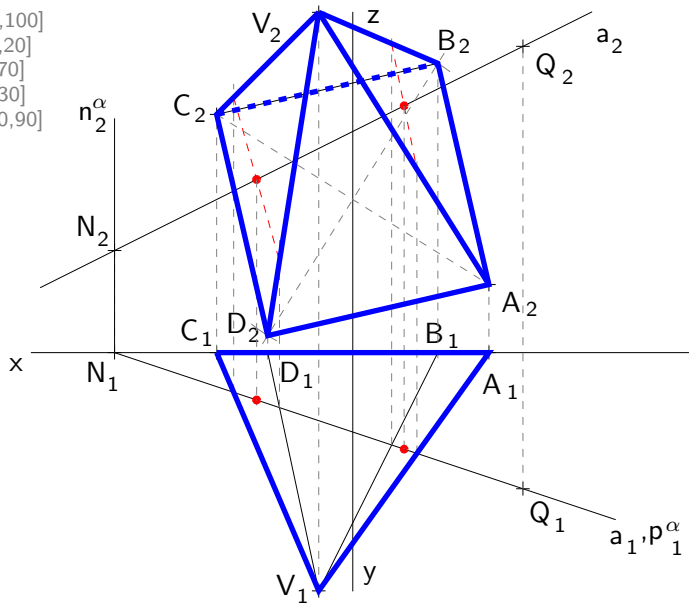

Mongeovo promítání - jehlan a přímka

V[10,70,100]
A[-40,0,20]
C[40,0,70]
N[70,0,30]
Q[-50,40,90]
a=NQ

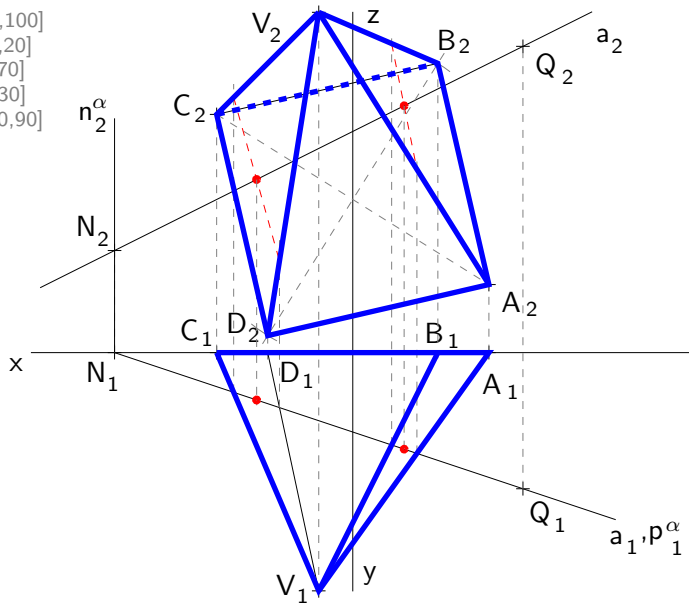

Mongeovo promítání - jehlan a přímka

V[10,70,100]
A[-40,0,20]
C[40,0,70]
N[70,0,30]
Q[-50,40,90]
a=NQ

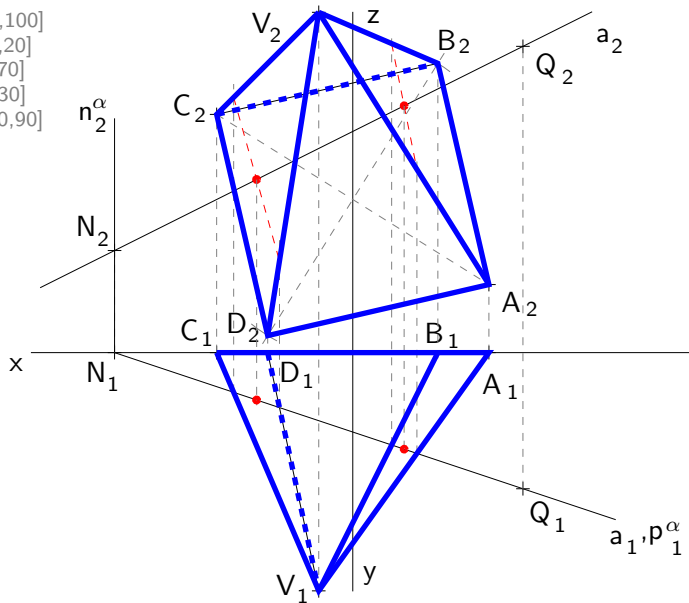

Mongeovo promítání - jehlan a přímka

V[10,70,100]
A[-40,0,20]
C[40,0,70]
N[70,0,30]
Q[-50,40,90]
a=NQ

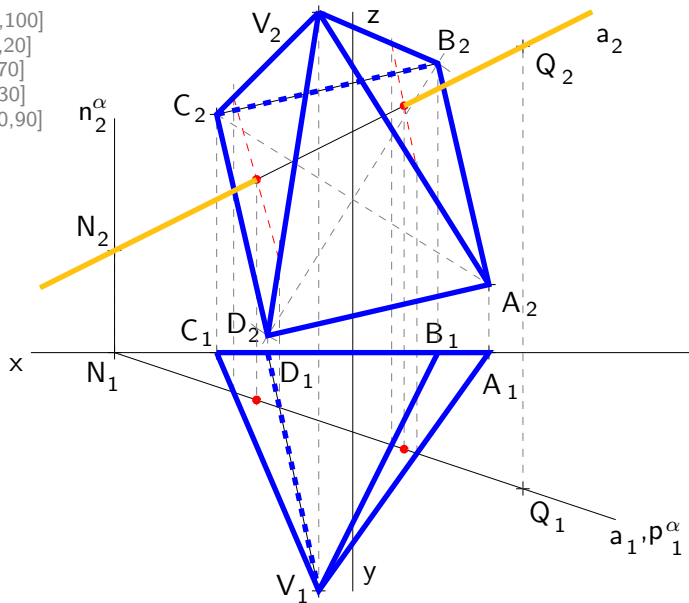

Mongeovo promítání - jehlan a přímka

$V[10,70,100]$
 $A[-40,0,20]$
 $C[40,0,70]$
 $N[70,0,30]$
 $Q[-50,40,90]$
 $a=NQ$

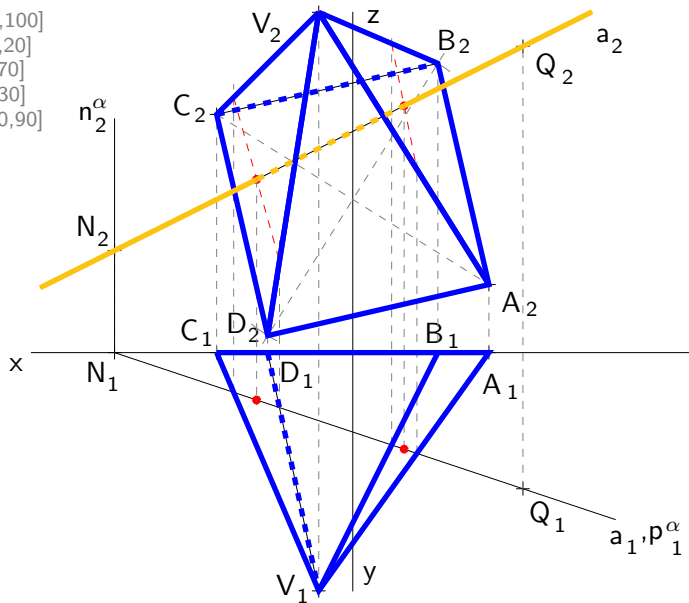

Mongeovo promítání - jehlan a přímka

V[10,70,100]
A[-40,0,20]
C[40,0,70]
N[70,0,30]
Q[-50,40,90]
a=NQ

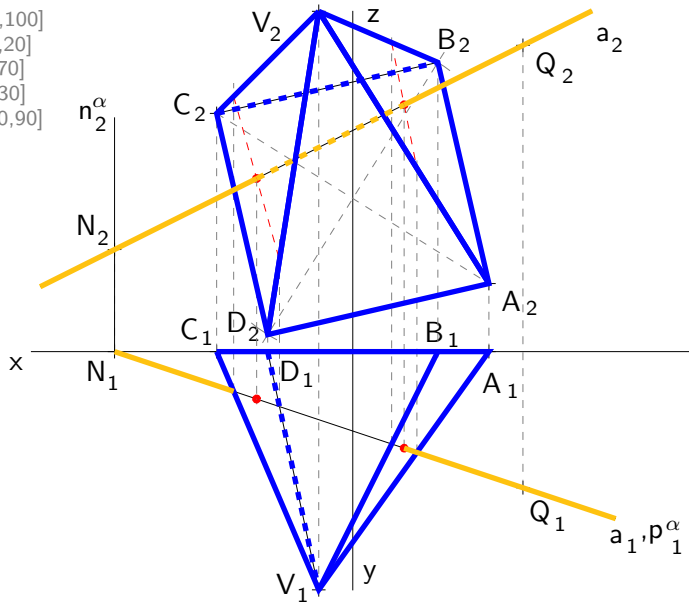

Mongeovo promítání - jehlan a přímka

V[10,70,100]
A[-40,0,20]
C[40,0,70]
N[70,0,30]
Q[-50,40,90]
a=NQ

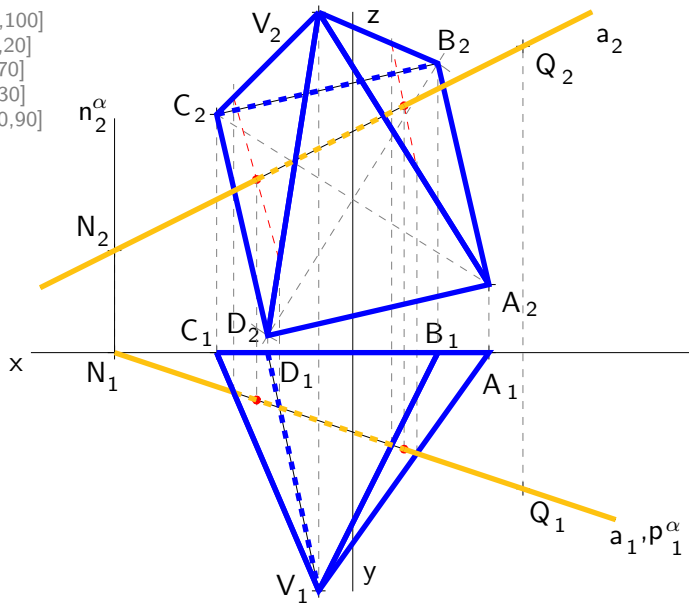

Mongeovo promítání - kužel a přímka

$V[10,0,70]$
 $S[-40,50,0]$
 $r=35$
 $a=PQ$
 $P[20,90,0]$
 $Q[-55,-20,75]$

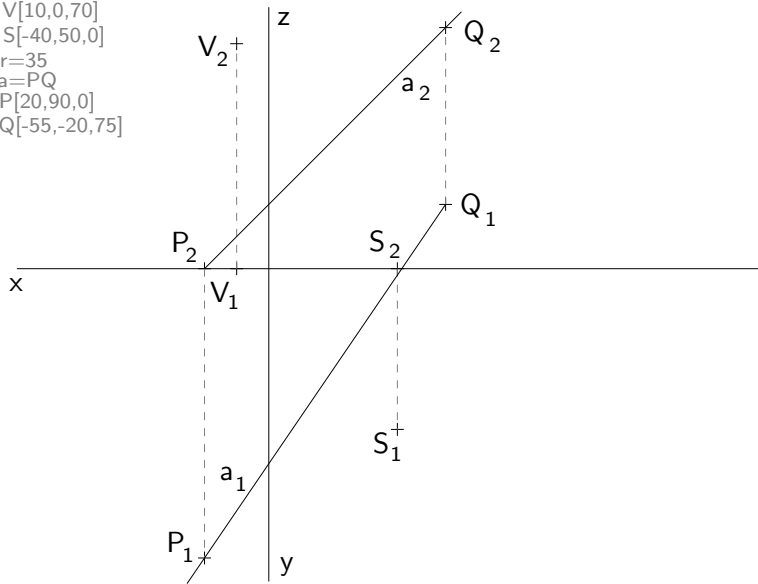

Mongeovo promítání - kužel a přímka

$V[10,0,70]$
 $S[-40,50,0]$
 $r=35$
 $a=PQ$
 $P[20,90,0]$
 $Q[-55,-20,75]$

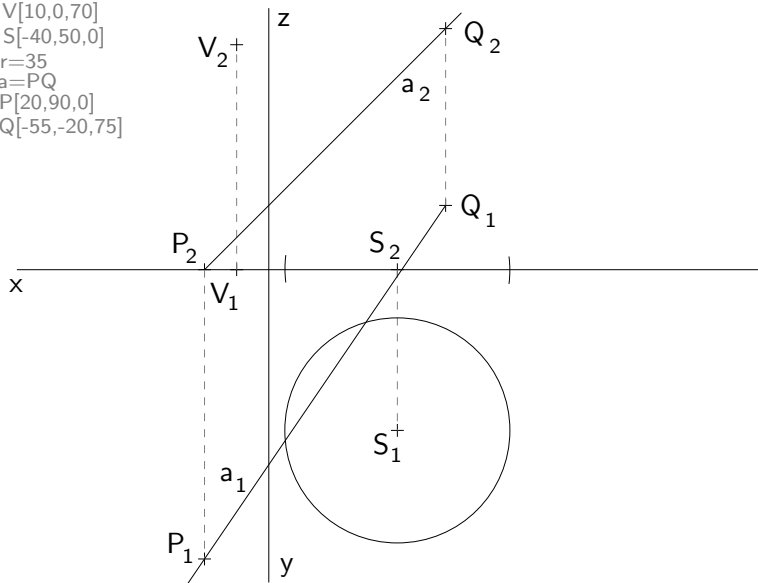

Mongeovo promítání - kužel a přímka

$V[10,0,70]$
 $S[-40,50,0]$
 $r=35$
 $a=PQ$
 $P[20,90,0]$
 $Q[-55,-20,75]$

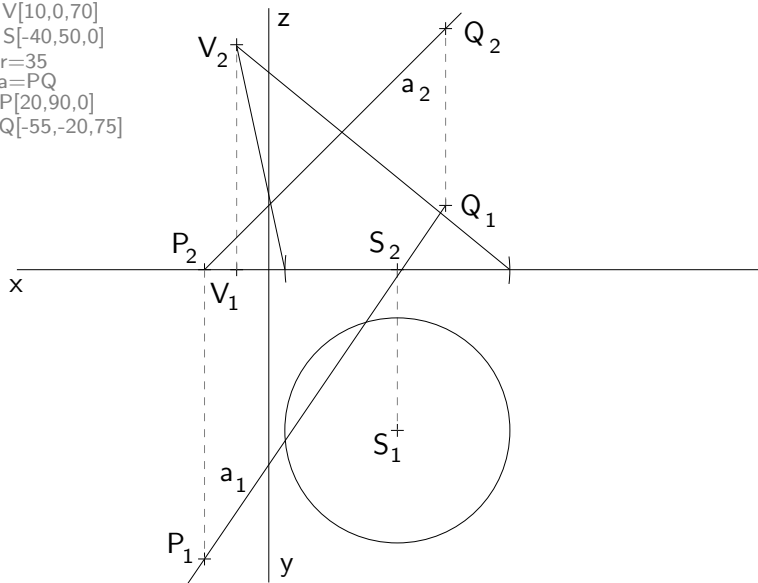

Mongeovo promítání - kužel a přímka

$V[10,0,70]$
 $S[-40,50,0]$
 $r=35$
 $a=PQ$
 $P[20,90,0]$
 $Q[-55,-20,75]$

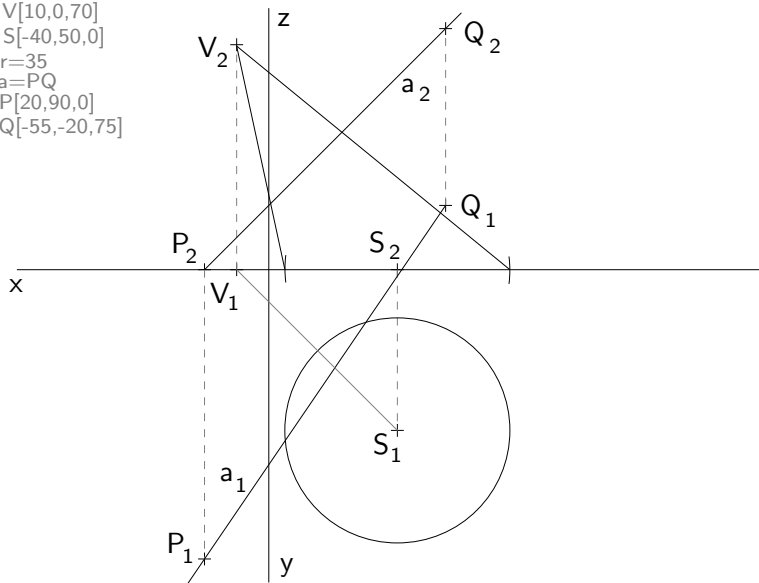

Mongeovo promítání - kužel a přímka

$V[10,0,70]$
 $S[-40,50,0]$
 $r=35$
 $a=PQ$
 $P[20,90,0]$
 $Q[-55,-20,75]$

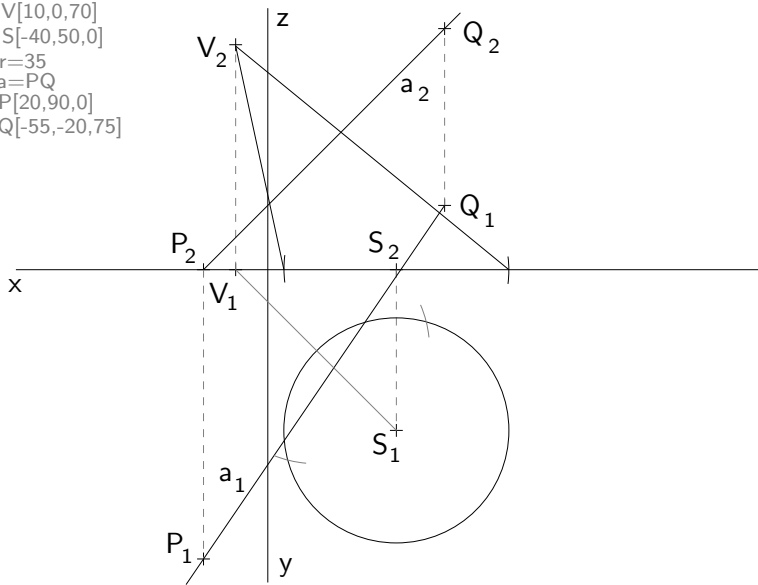

Mongeovo promítání - kužel a přímka

$V[10,0,70]$
 $S[-40,50,0]$
 $r=35$
 $a=PQ$
 $P[20,90,0]$
 $Q[-55,-20,75]$

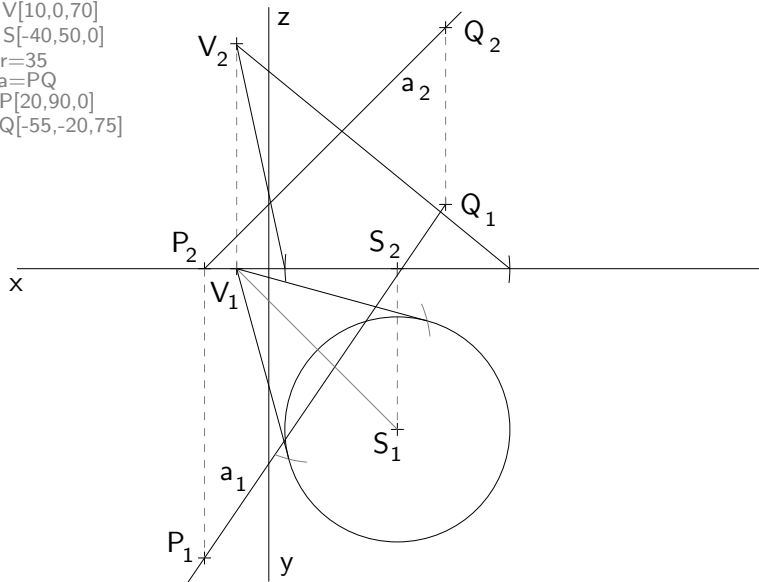

Mongeovo promítání - kužel a přímka

$V[10,0,70]$
 $S[-40,50,0]$
 $r=35$
 $a=PQ$
 $P[20,90,0]$
 $Q[-55,-20,75]$

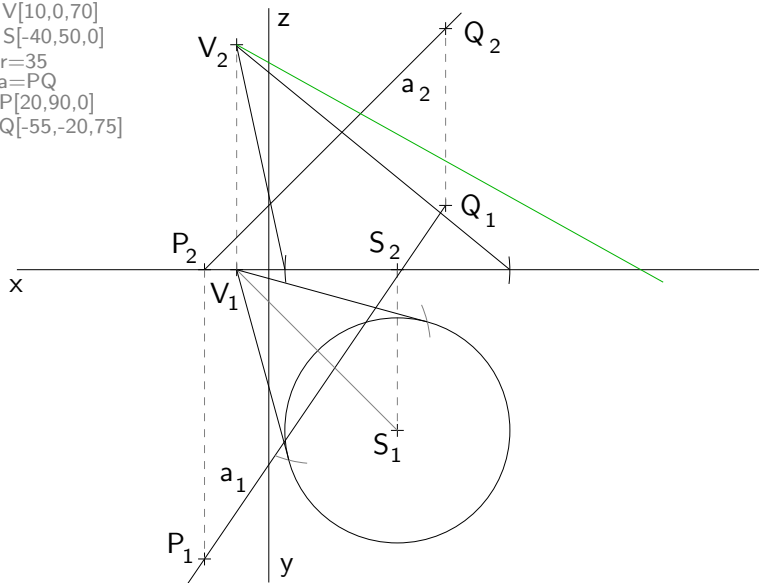

Mongeovo promítání - kužel a přímka

$V[10,0,70]$
 $S[-40,50,0]$
 $r=35$
 $a=PQ$
 $P[20,90,0]$
 $Q[-55,-20,75]$

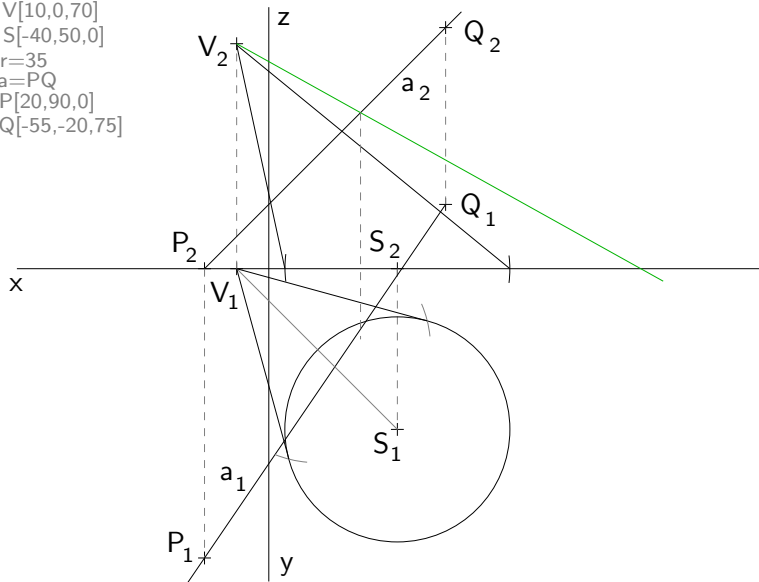

Mongeovo promítání - kužel a přímka

$V[10,0,70]$
 $S[-40,50,0]$
 $r=35$
 $a=PQ$
 $P[20,90,0]$
 $Q[-55,-20,75]$

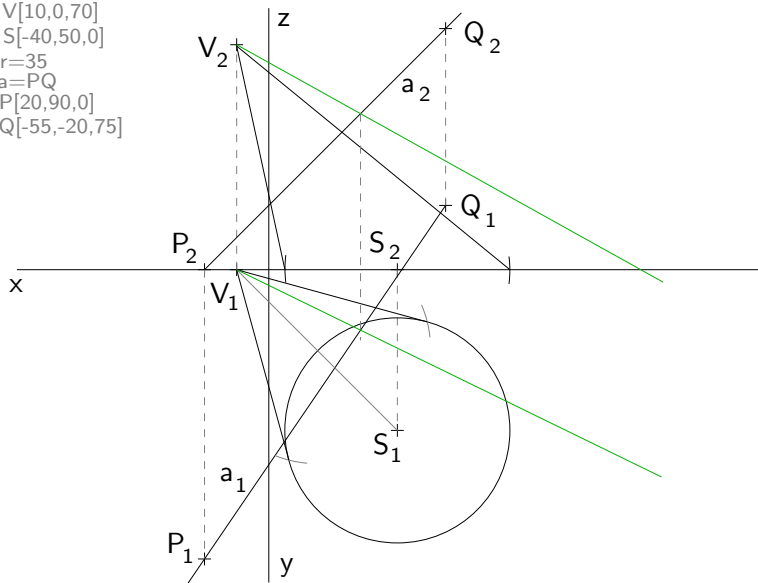

Mongeovo promítání - kužel a přímka

$V[10,0,70]$
 $S[-40,50,0]$
 $r=35$
 $a=PQ$
 $P[20,90,0]$
 $Q[-55,-20,75]$

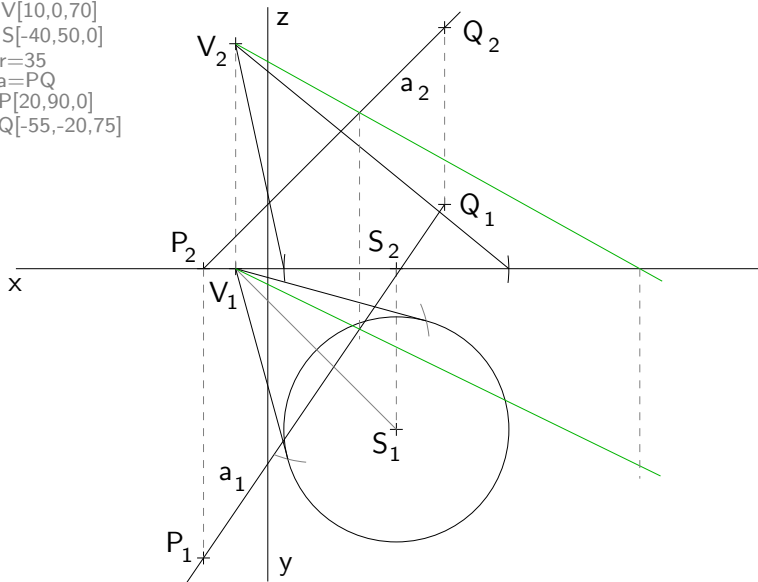

Mongeovo promítání - kužel a přímka

$V[10,0,70]$
 $S[-40,50,0]$
 $r=35$
 $a=PQ$
 $P[20,90,0]$
 $Q[-55,-20,75]$

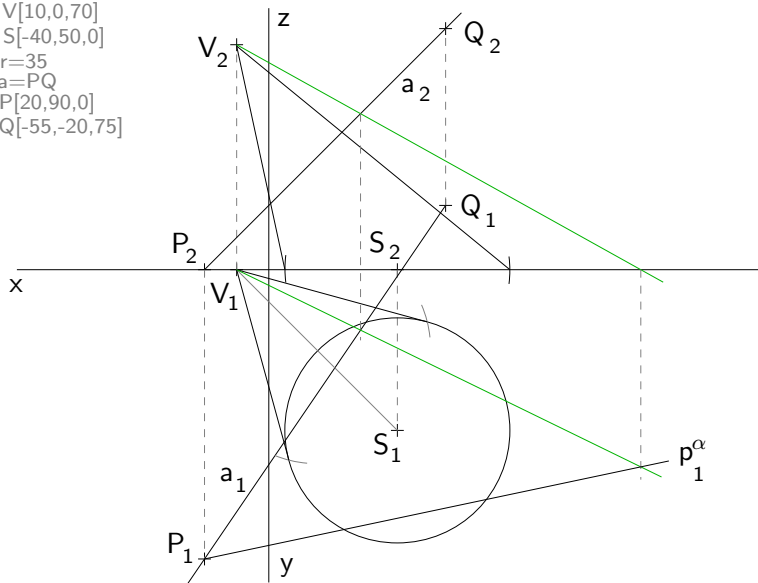

Mongeovo promítání - kužel a přímka

$V[10,0,70]$
 $S[-40,50,0]$
 $r=35$
 $a=PQ$
 $P[20,90,0]$
 $Q[-55,-20,75]$

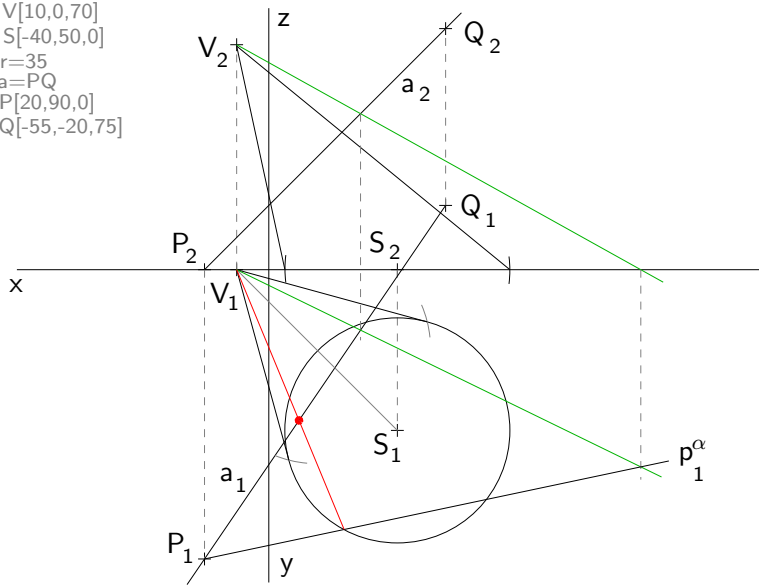

Mongeovo promítání - kužel a přímka

$V[10,0,70]$
 $S[-40,50,0]$
 $r=35$
 $a=PQ$
 $P[20,90,0]$
 $Q[-55,-20,75]$

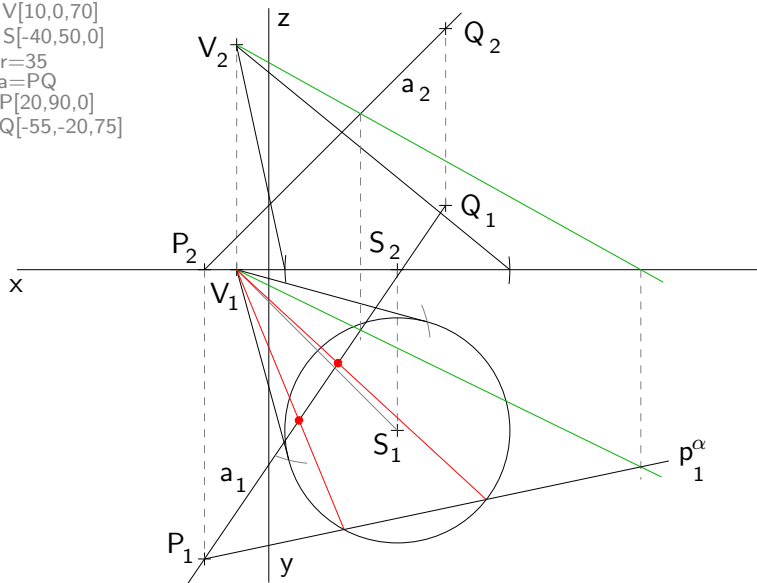

Mongeovo promítání - kužel a přímka

$V[10,0,70]$
 $S[-40,50,0]$
 $r=35$
 $a=PQ$
 $P[20,90,0]$
 $Q[-55,-20,75]$

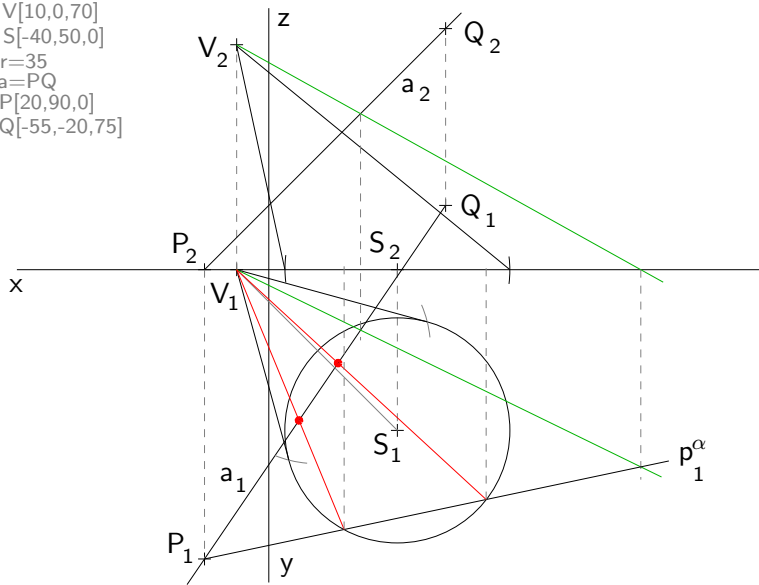

Mongeovo promítání - kužel a přímka

$V[10,0,70]$
 $S[-40,50,0]$
 $r=35$
 $a=PQ$
 $P[20,90,0]$
 $Q[-55,-20,75]$

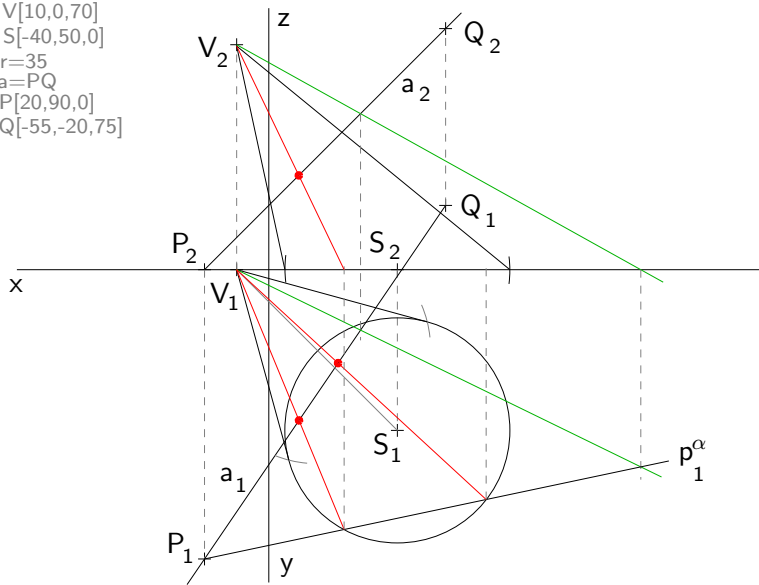

Mongeovo promítání - kužel a přímka

$V[10,0,70]$
 $S[-40,50,0]$
 $r=35$
 $a=PQ$
 $P[20,90,0]$
 $Q[-55,-20,75]$

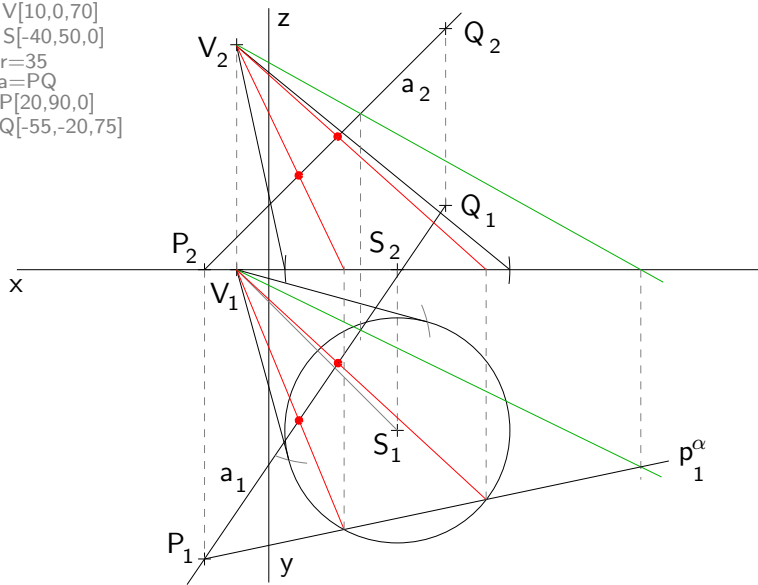

Mongeovo promítání - kužel a přímka

$V[10,0,70]$
 $S[-40,50,0]$
 $r=35$
 $a=PQ$
 $P[20,90,0]$
 $Q[-55,-20,75]$

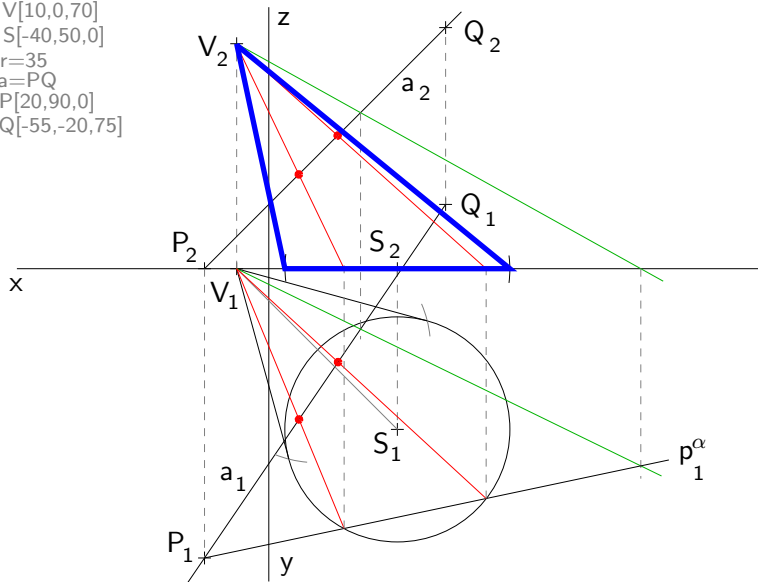

Mongeovo promítání - kužel a přímka

$V[10,0,70]$
 $S[-40,50,0]$
 $r=35$
 $a=PQ$
 $P[20,90,0]$
 $Q[-55,-20,75]$

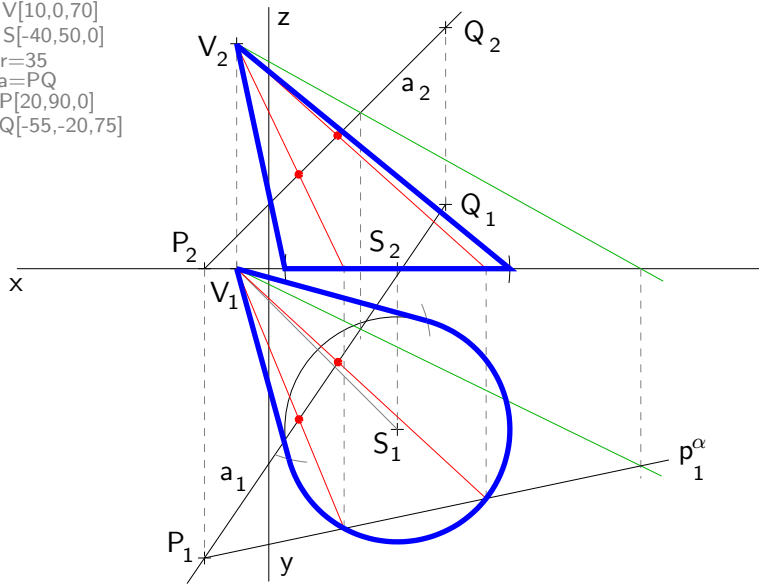

Mongeovo promítání - kužel a přímka

$V[10,0,70]$
 $S[-40,50,0]$
 $r=35$
 $a=PQ$
 $P[20,90,0]$
 $Q[-55,-20,75]$

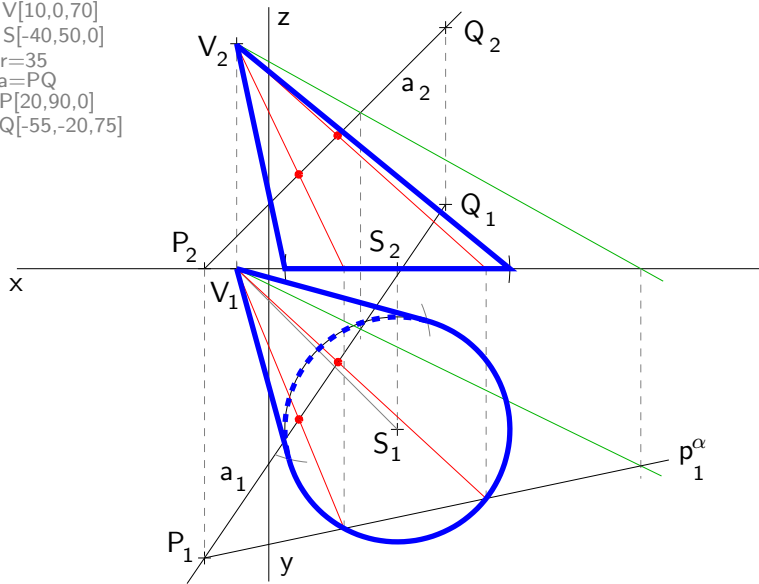

Mongeovo promítání - kužel a přímka

$V[10,0,70]$
 $S[-40,50,0]$
 $r=35$
 $a=PQ$
 $P[20,90,0]$
 $Q[-55,-20,75]$

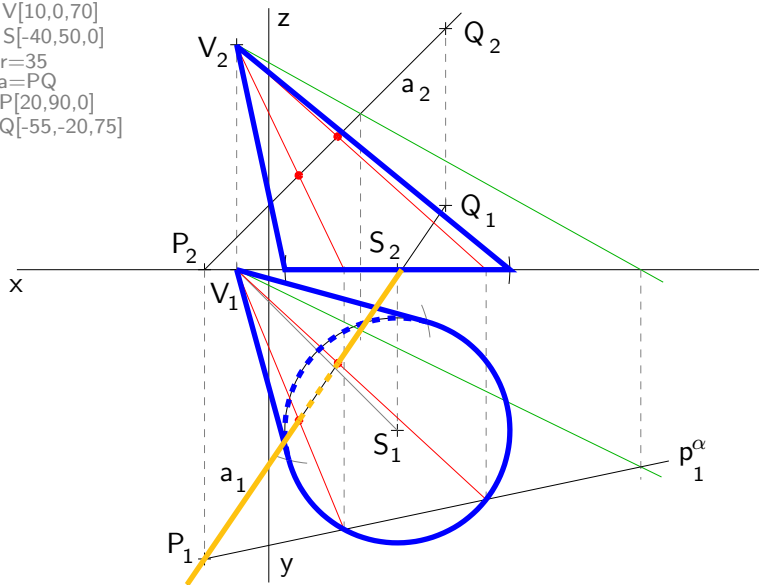

Mongeovo promítání - kužel a přímka

$V[10,0,70]$
 $S[-40,50,0]$
 $r=35$
 $a=PQ$
 $P[20,90,0]$
 $Q[-55,-20,75]$

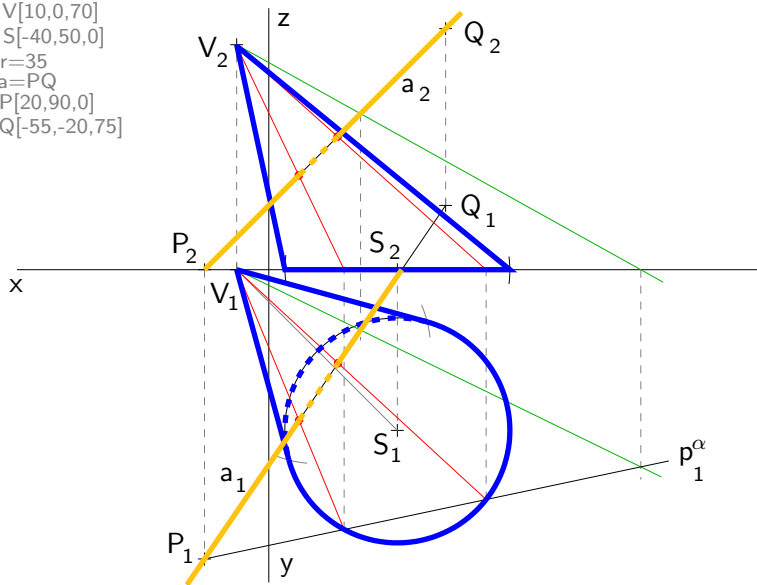

Axonometrie - průnik válce a kužele

$XYZ(70,80,70)$

$S=[0,0,0]$

$r=30$

$v=60$

$S'=[0,30,0]$

$r'=40$

$v'=60$

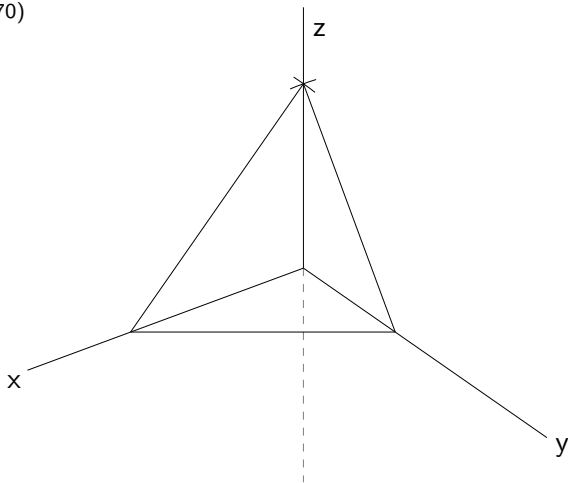

Axonometrie - průnik válce a kužele

$XYZ(70,80,70)$

$S=[0,0,0]$

$r=30$

$v=60$

$S'=[0,30,0]$

$r'=40$

$v'=60$

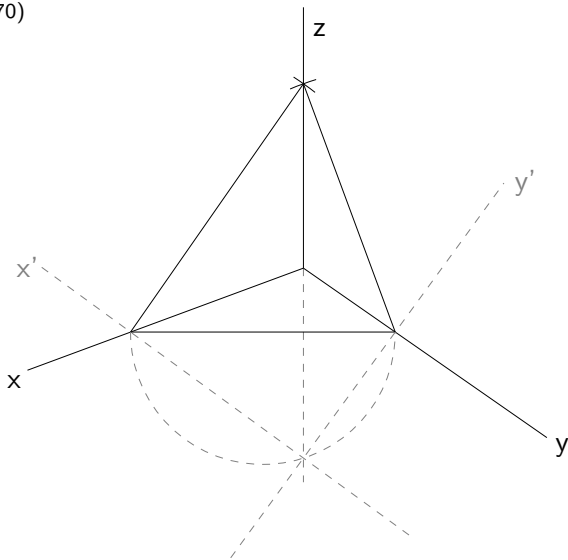

Axonometrie - průnik válce a kužele

$XYZ(70,80,70)$

$S=[0,0,0]$

$r=30$

$v=60$

$S'=[0,30,0]$

$r'=40$

$v'=60$

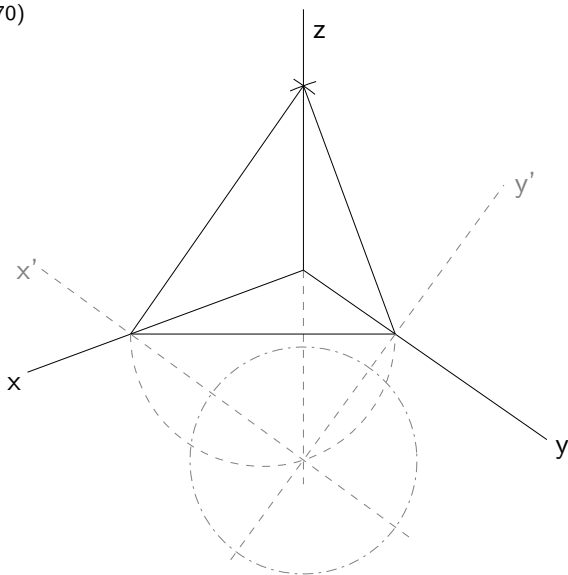

Axonometrie - průnik válce a kužele

$XYZ(70,80,70)$

$S=[0,0,0]$

$r=30$

$v=60$

$S'=[0,30,0]$

$r'=40$

$v'=60$

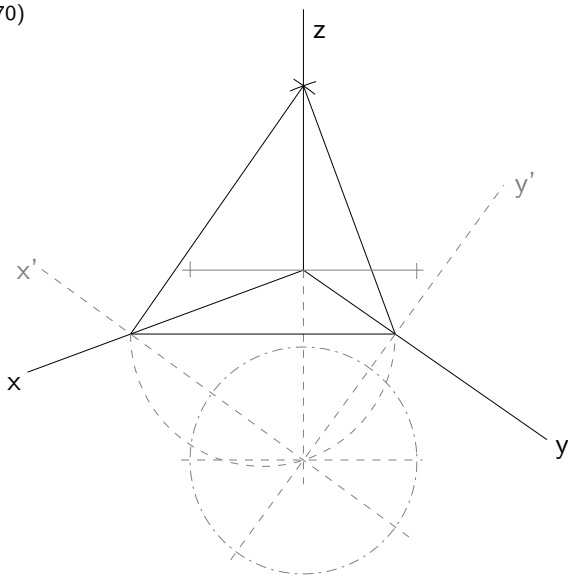

Axonometrie - průnik válce a kužele

$XYZ(70,80,70)$

$S=[0,0,0]$

$r=30$

$v=60$

$S'=[0,30,0]$

$r'=40$

$v'=60$

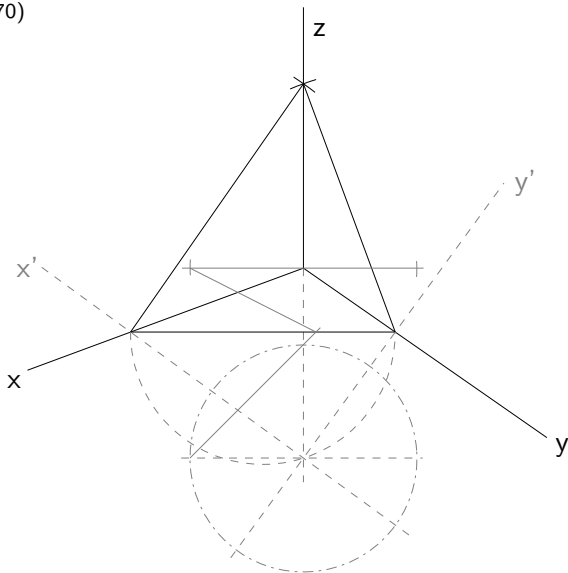

Axonometrie - průnik válce a kužele

$XYZ(70,80,70)$

$S=[0,0,0]$

$r=30$

$v=60$

$S'=[0,30,0]$

$r'=40$

$v'=60$

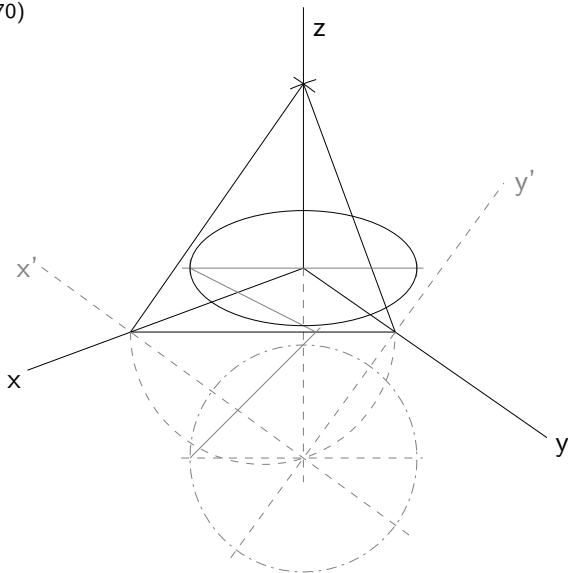

Axonometrie - průnik válce a kužele

XYZ(70,80,70)

$S=[0,0,0]$

$r=30$

$v=60$

$S'=[0,30,0]$

$r'=40$

$v'=60$

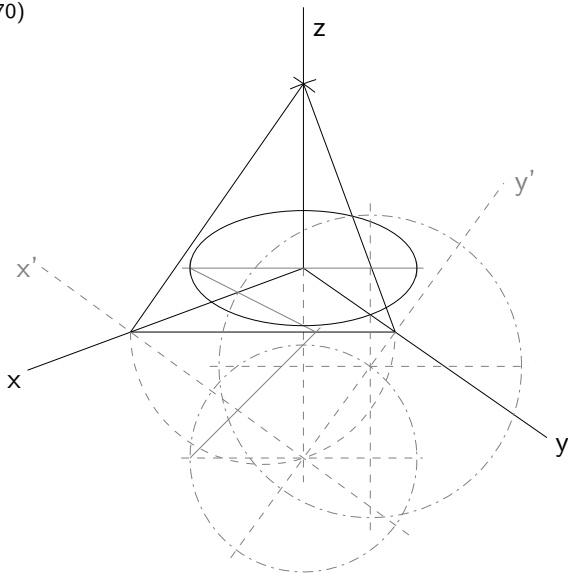

Axonometrie - průnik válce a kužele

XYZ(70,80,70)

$S=[0,0,0]$

$r=30$

$v=60$

$S'=[0,30,0]$

$r'=40$

$v'=60$

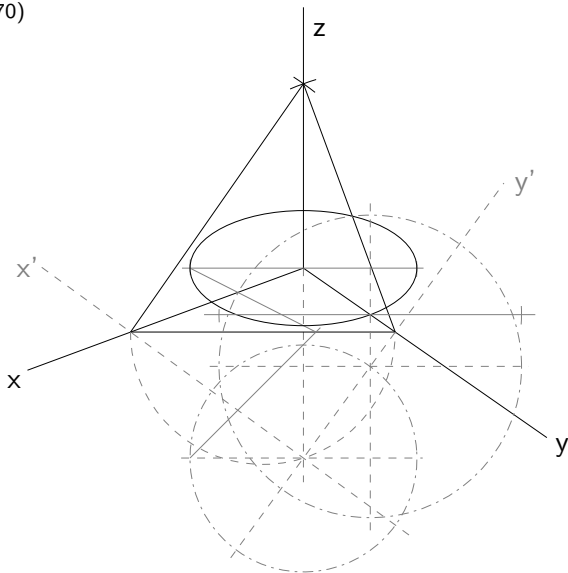

Axonometrie - průnik válce a kužele

$XYZ(70,80,70)$

$S=[0,0,0]$

$r=30$

$v=60$

$S'=[0,30,0]$

$r'=40$

$v'=60$

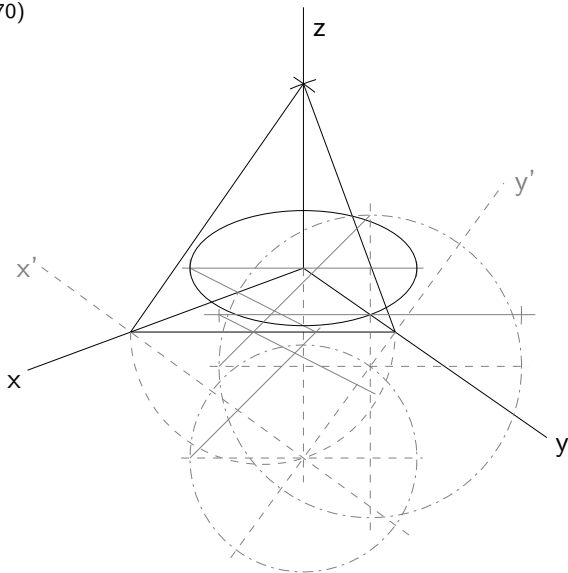

Axonometrie - průnik válce a kužele

$XYZ(70,80,70)$

$S=[0,0,0]$

$r=30$

$v=60$

$S'=[0,30,0]$

$r'=40$

$v'=60$

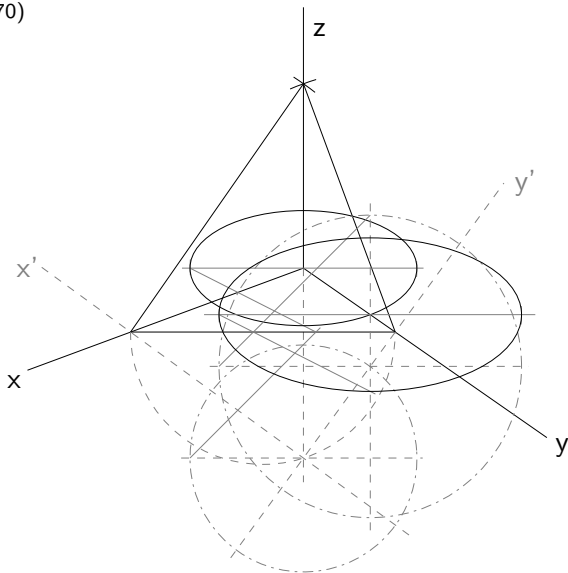

Axonometrie - průnik válce a kužele

$XYZ(70,80,70)$

$S=[0,0,0]$

$r=30$

$v=60$

$S'=[0,30,0]$

$r'=40$

$v'=60$

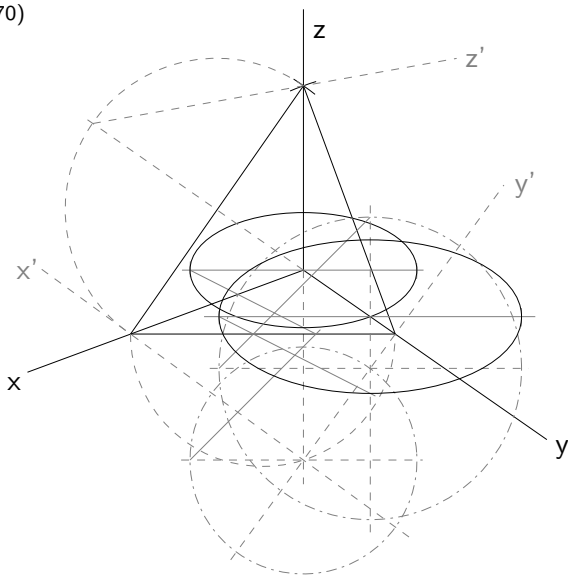

Axonometrie - průnik válce a kužele

$XYZ(70,80,70)$

$S=[0,0,0]$

$r=30$

$v=60$

$S'=[0,30,0]$

$r'=40$

$v'=60$

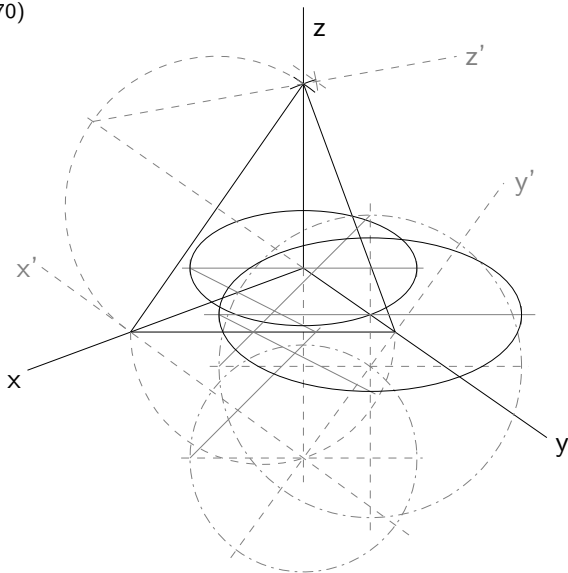

Axonometrie - průnik válce a kužele

$XYZ(70,80,70)$

$S=[0,0,0]$

$r=30$

$v=60$

$S'=[0,30,0]$

$r'=40$

$v'=60$

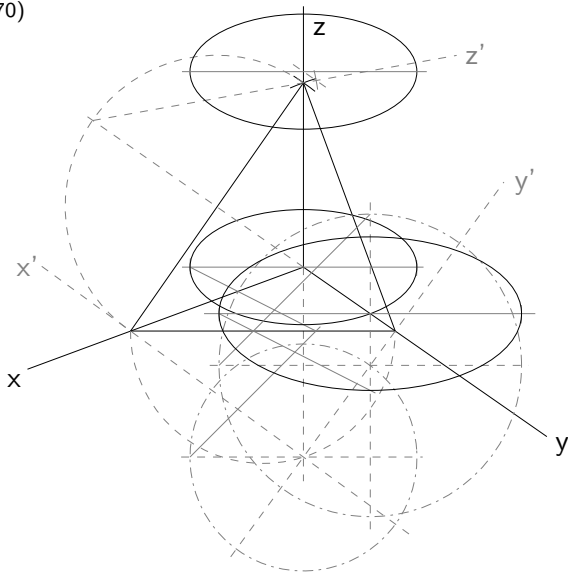

Axonometrie - průnik válce a kužele

XYZ(70,80,70)

$S=[0,0,0]$

$r=30$

$v=60$

$S'=[0,30,0]$

$r'=40$

$v'=60$

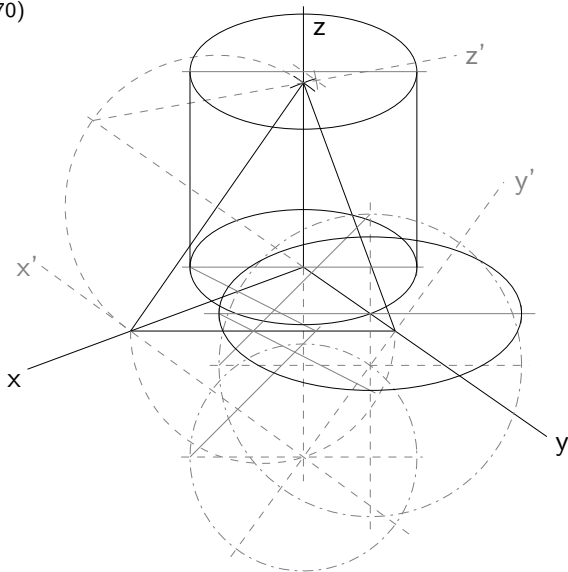

Axonometrie - průnik válce a kužele

$XYZ(70,80,70)$

$S=[0,0,0]$

$r=30$

$v=60$

$S'=[0,30,0]$

$r'=40$

$v'=60$

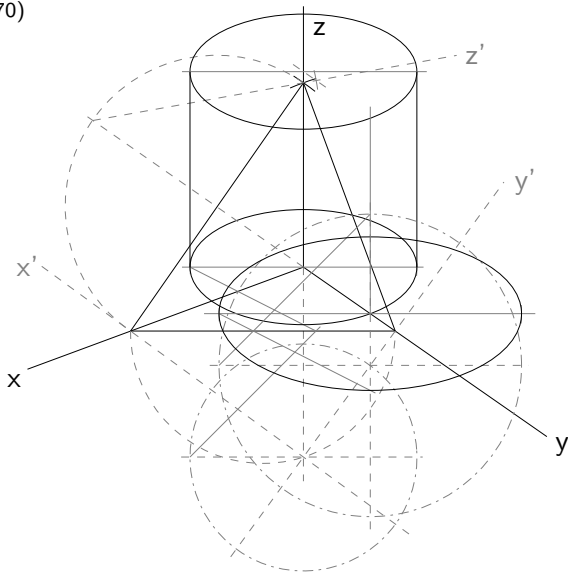

Axonometrie - průnik válce a kužele

$XYZ(70,80,70)$

$S=[0,0,0]$

$r=30$

$v=60$

$S'=[0,30,0]$

$r'=40$

$v'=60$

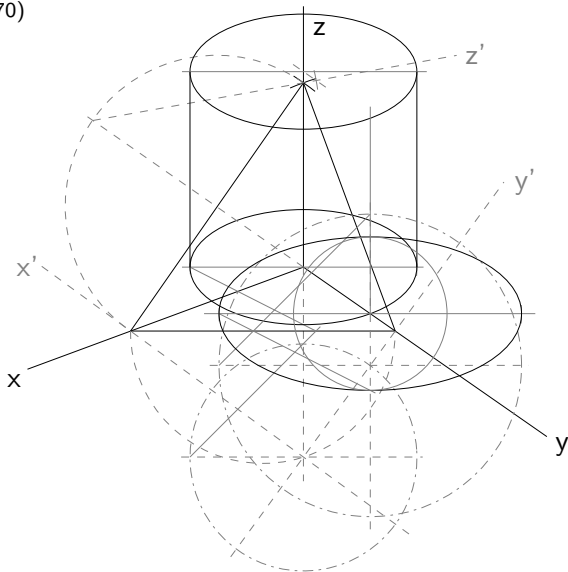

Axonometrie - průnik válce a kužele

$XYZ(70,80,70)$

$S=[0,0,0]$

$r=30$

$v=60$

$S'=[0,30,0]$

$r'=40$

$v'=60$

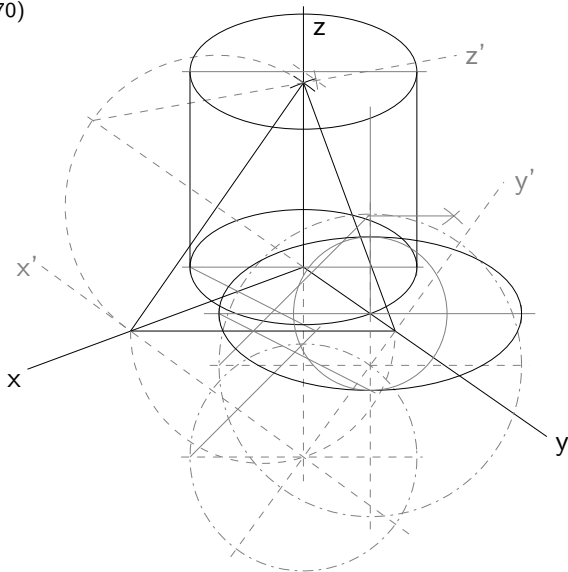

Axonometrie - průnik válce a kužele

$XYZ(70,80,70)$

$S=[0,0,0]$

$r=30$

$v=60$

$S'=[0,30,0]$

$r'=40$

$v'=60$

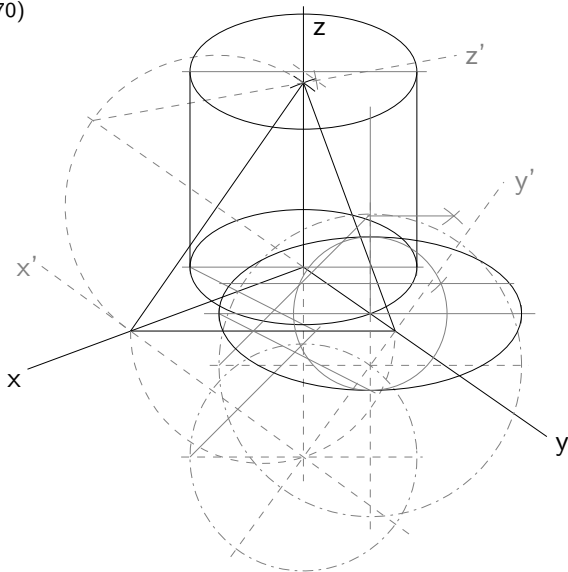

Axonometrie - průnik válce a kužele

XYZ(70,80,70)

$S=[0,0,0]$

$r=30$

$v=60$

$S'=[0,30,0]$

$r'=40$

$v'=60$

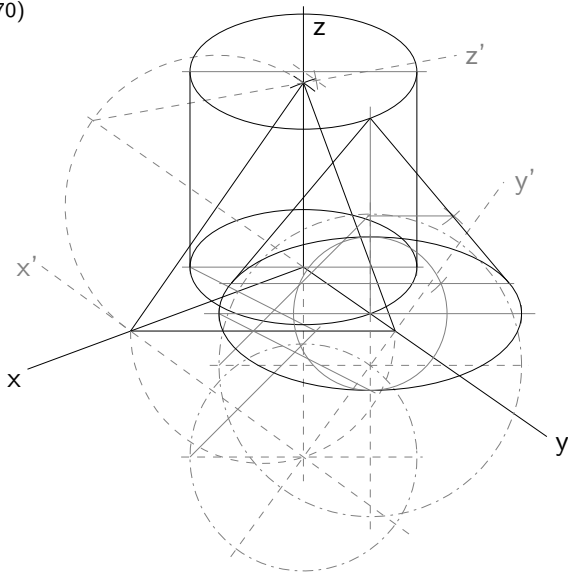

Axonometrie - průnik válce a kužele

XYZ(70,80,70)

$S=[0,0,0]$

$r=30$

$v=60$

$S'=[0,30,0]$

$r'=40$

$v'=60$

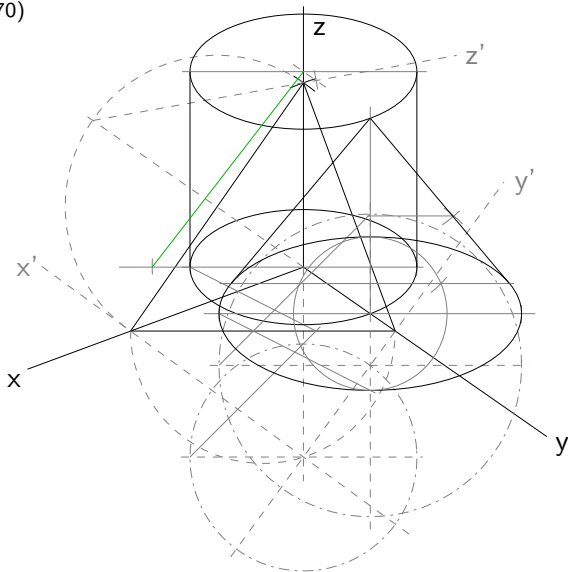

Axonometrie - průnik válce a kužele

XYZ(70,80,70)

$S=[0,0,0]$

$r=30$

$v=60$

$S'=[0,30,0]$

$r'=40$

$v'=60$

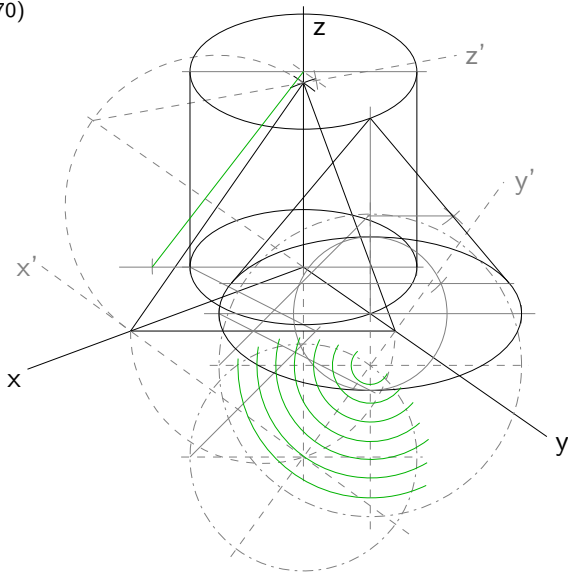

Axonometrie - průnik válce a kužele

XYZ(70,80,70)

$S=[0,0,0]$

$r=30$

$v=60$

$S'=[0,30,0]$

$r'=40$

$v'=60$

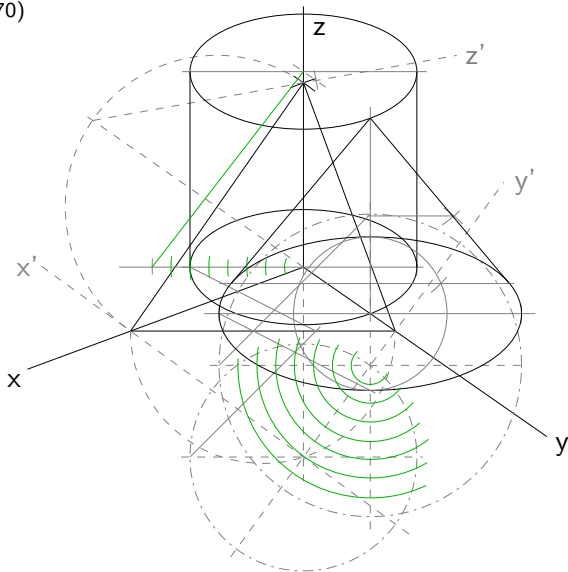

Axonometrie - průnik válce a kužele

XYZ(70,80,70)

$S=[0,0,0]$

$r=30$

$v=60$

$S'=[0,30,0]$

$r'=40$

$v'=60$

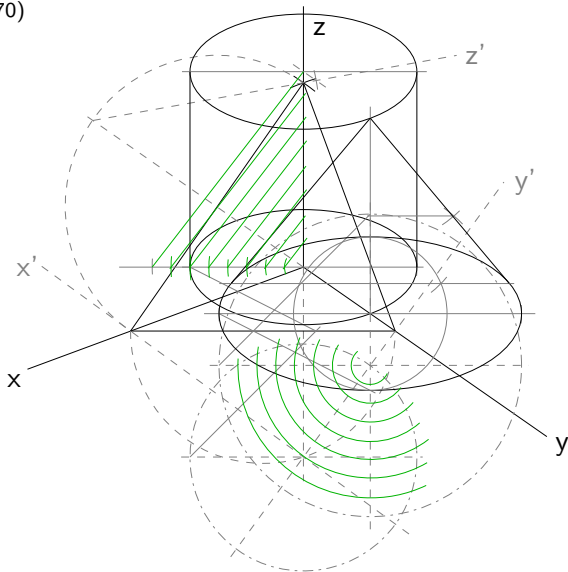

Axonometrie - průnik válce a kužele

XYZ(70,80,70)

$S=[0,0,0]$

$r=30$

$v=60$

$S'=[0,30,0]$

$r'=40$

$v'=60$

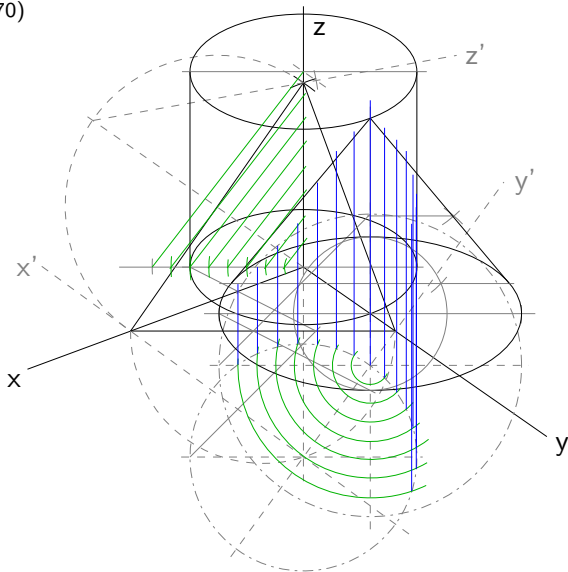

Axonometrie - průnik válce a kužele

$XYZ(70,80,70)$

$S=[0,0,0]$

$r=30$

$v=60$

$S'=[0,30,0]$

$r'=40$

$v'=60$

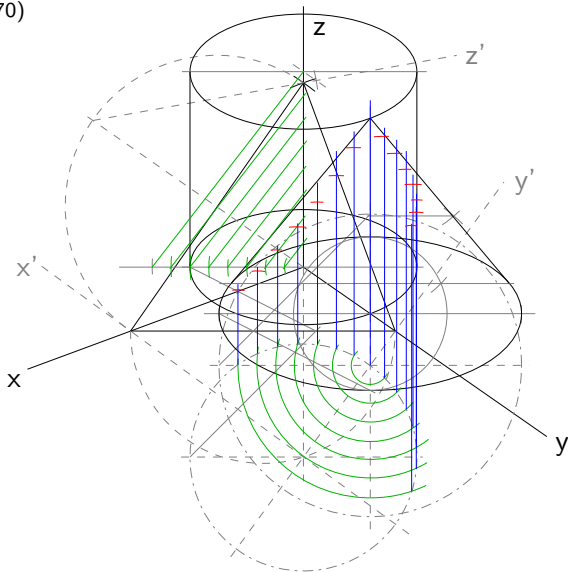

Axonometrie - průnik válce a kužele

XYZ(70,80,70)

$S=[0,0,0]$

$r=30$

$v=60$

$S'=[0,30,0]$

$r'=40$

$v'=60$

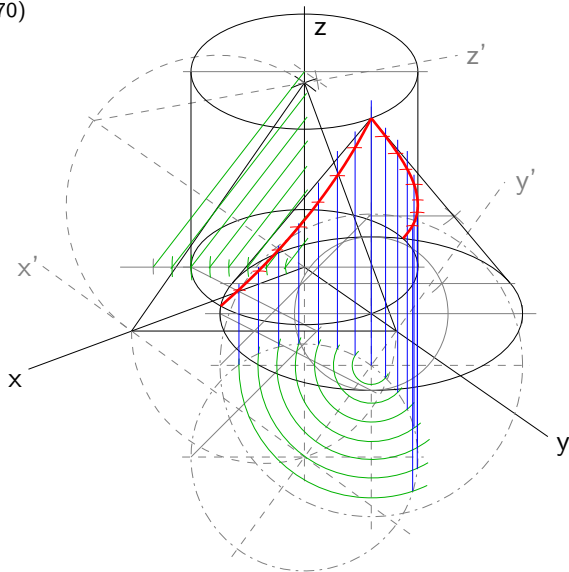

Axonometrie - zářezová metoda

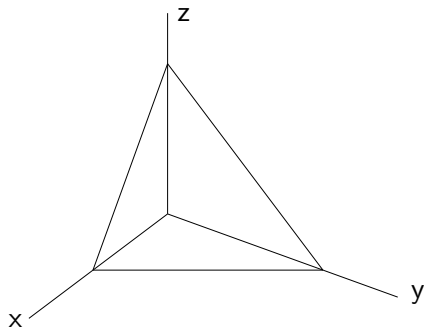

Axonometrie - zářezová metoda

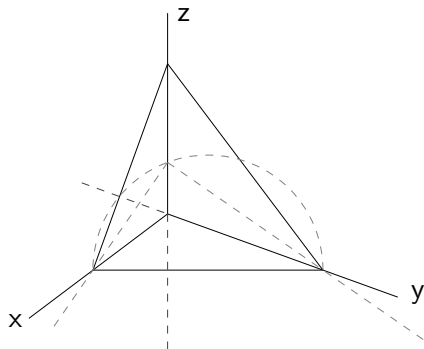

Axonometrie - zřezová metoda

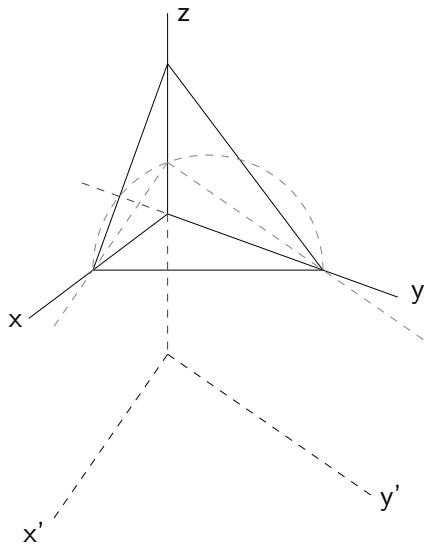

Axonometrie - zřezová metoda

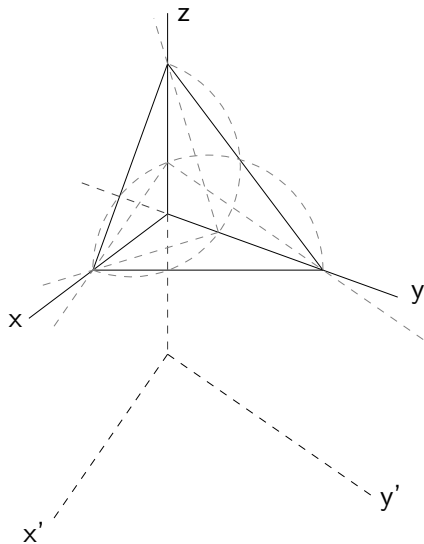

Axonometrie - zřezová metoda

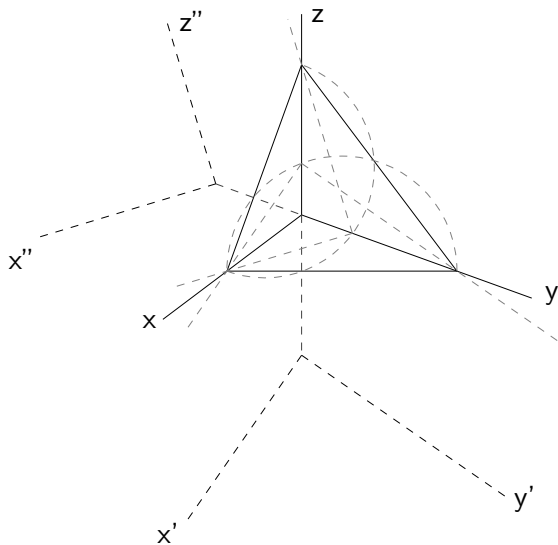

Axonometrie - zřezová metoda

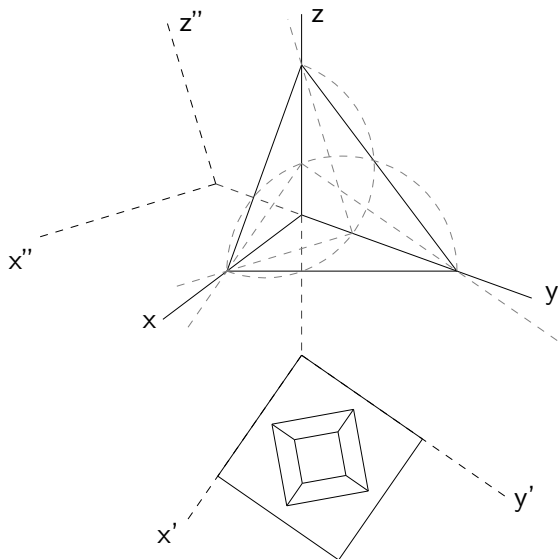

Axonometrie - zřezová metoda

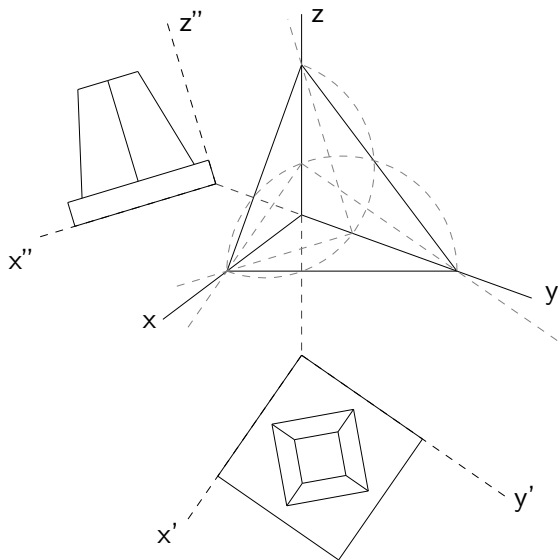

Axonometrie - zřezová metoda

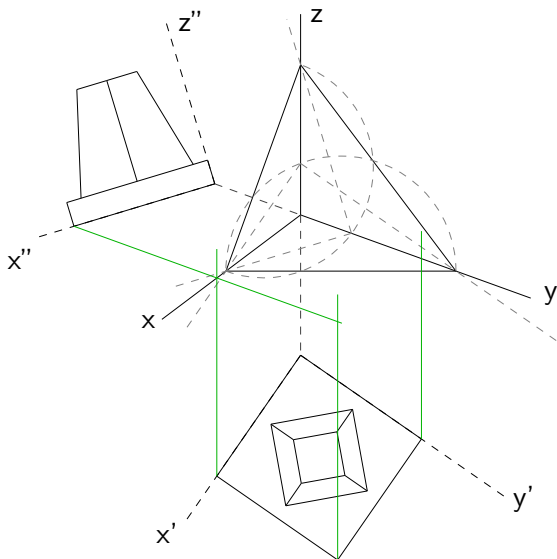

Axonometrie - zřezová metoda

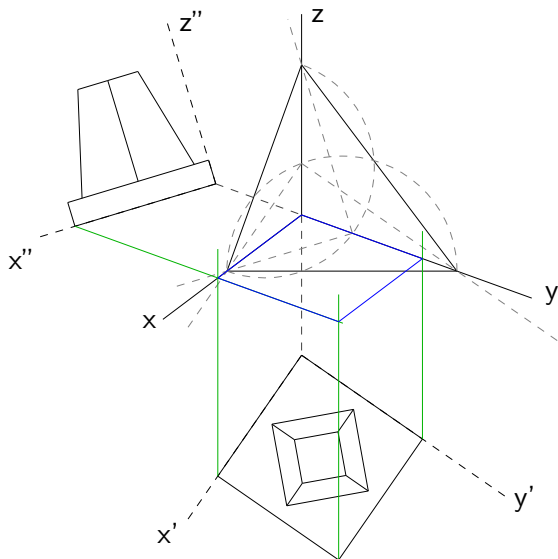

Axonometrie - zřezová metoda

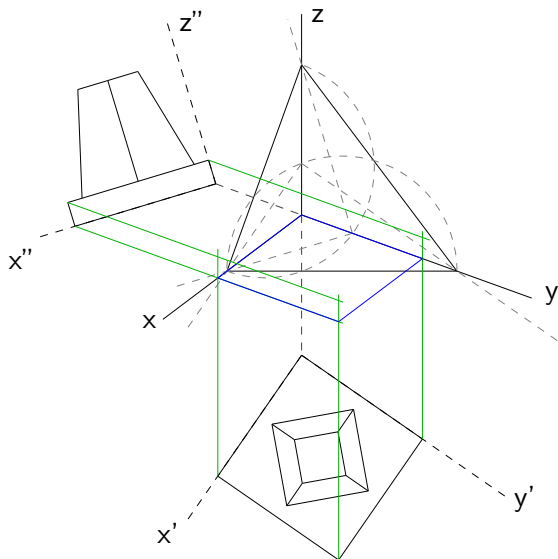

Axonometrie - zřezová metoda

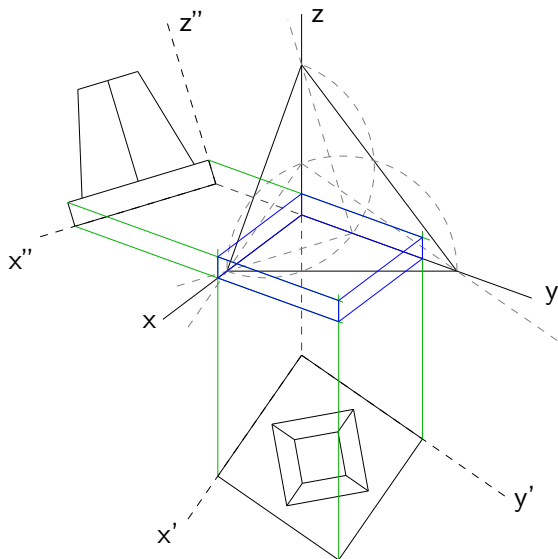

Axonometrie - zřezová metoda

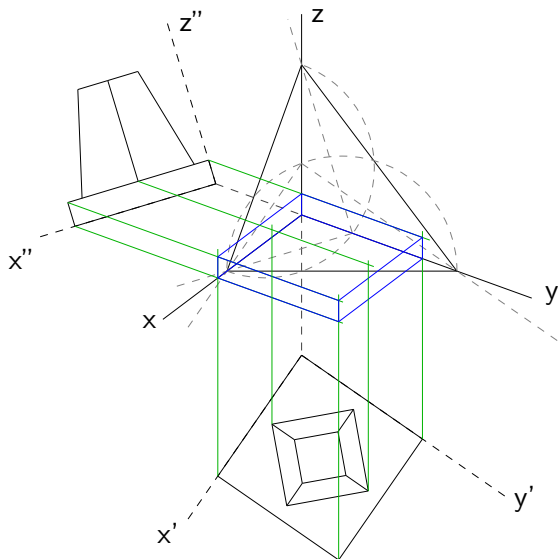

Axonometrie - zřezová metoda

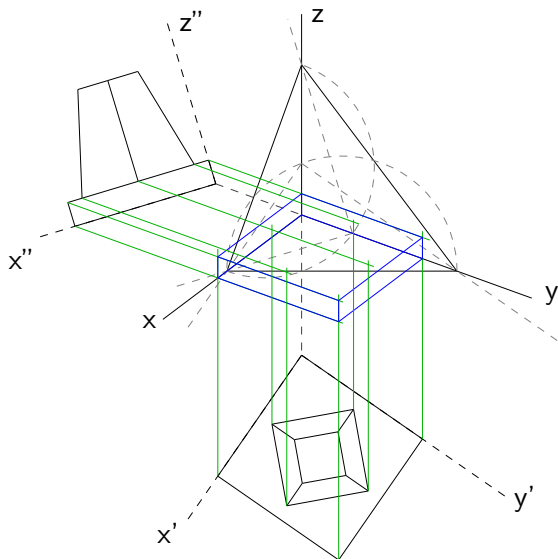

Axonometrie - zřezová metoda

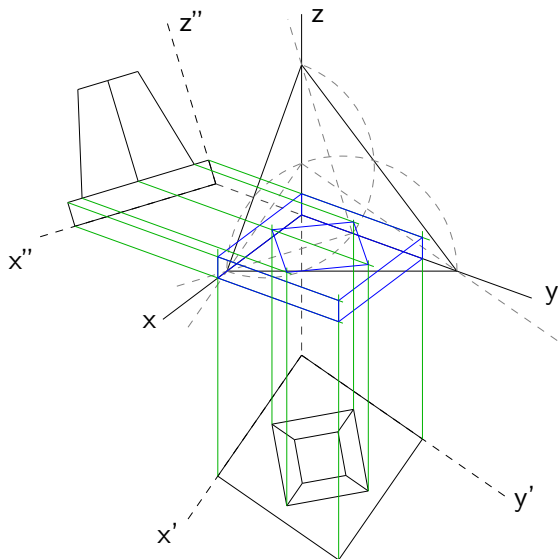

Axonometrie - zřezová metoda

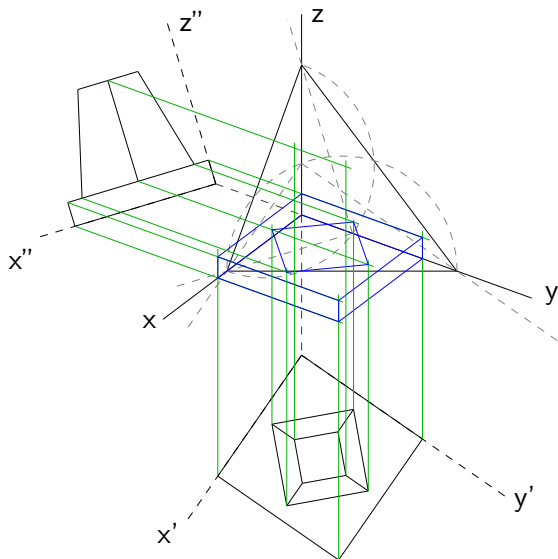

Axonometrie - zřezová metoda

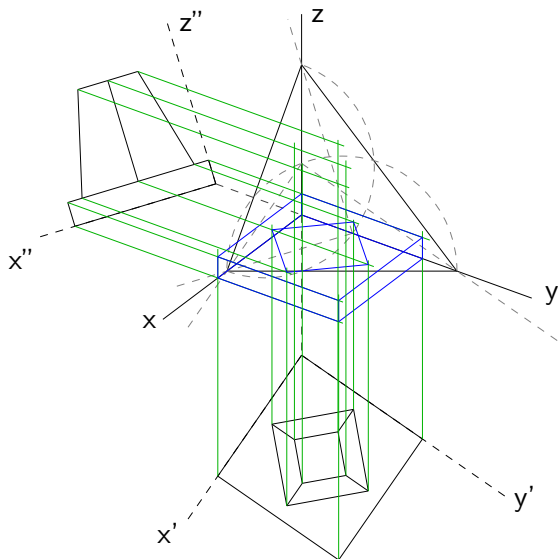

Axonometrie - zřezová metoda

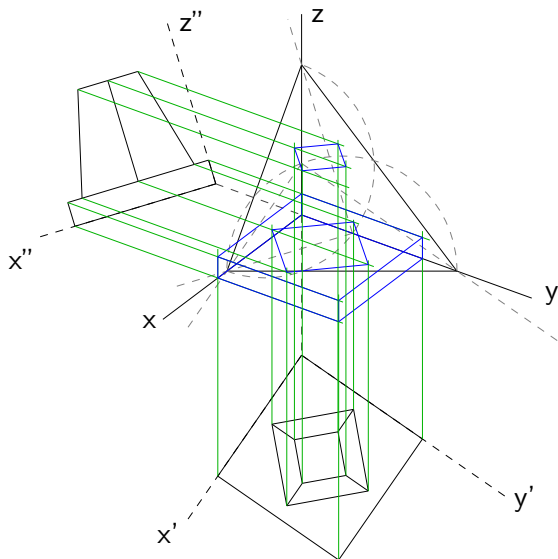

Axonometrie - zřezová metoda

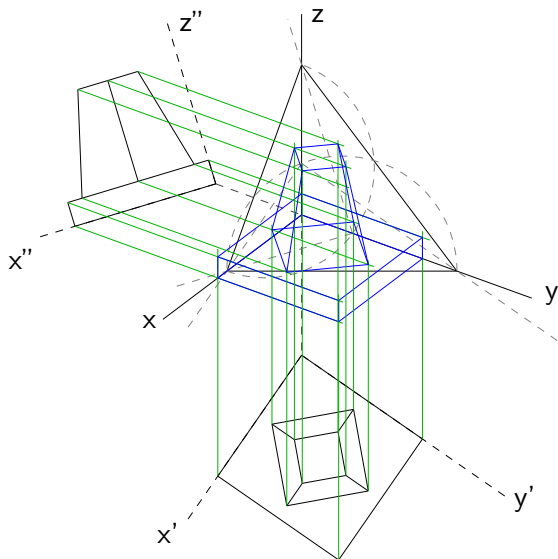

Axonometrie - zřezová metoda

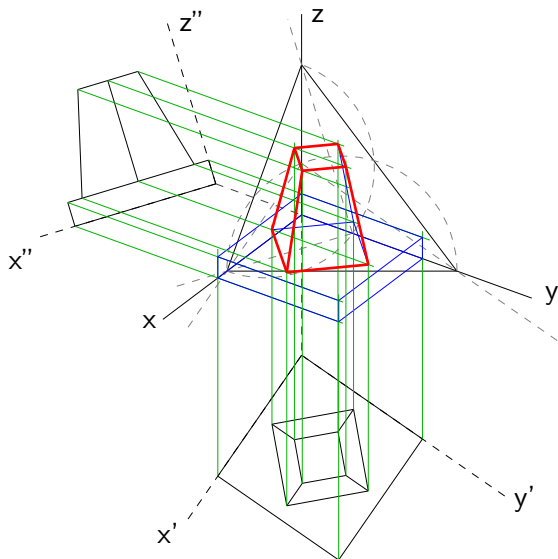

Axonometrie - zřezová metoda

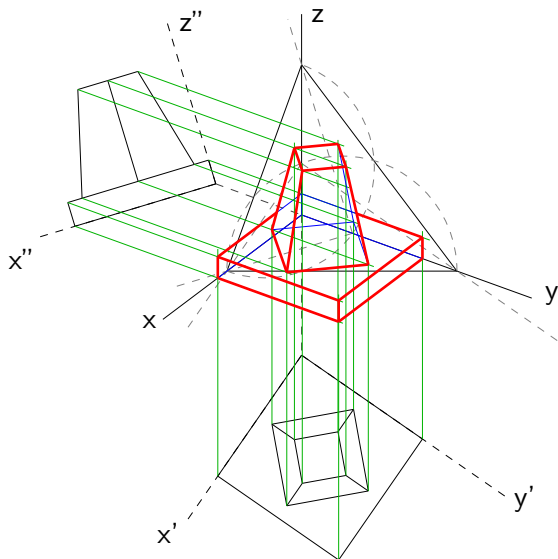

Axonometrie - zářezová metoda

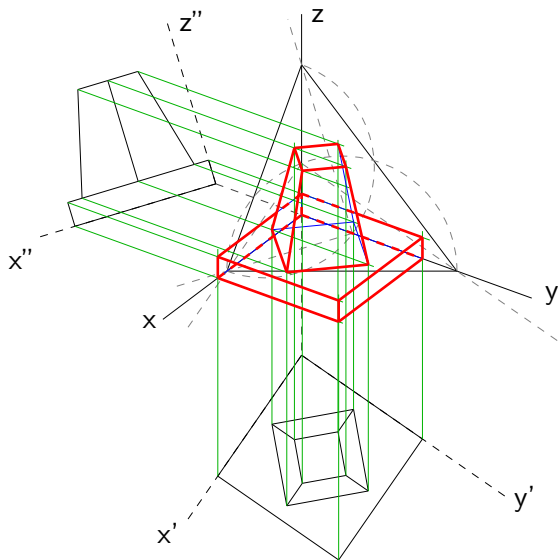

Axonometrie - zřezová metoda

